

# TCB1000 Series

## User Guide

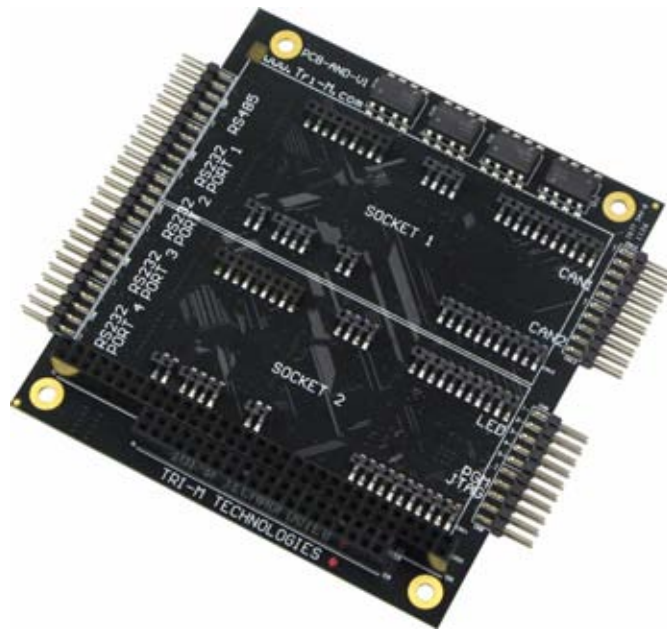

CAN Bus, Socket Modems & Serial Communication

Tri-M Technologies Inc.

Toll Free: 1.800.665.5600

Direct: +1.604.945.9565

Email: [info@tri-m.com](mailto:info@tri-m.com)

Web: [www.tri-m.com](http://www.tri-m.com)

# Important Notes

## About Tri-M Technologies Inc.

Tri-M Technologies Inc. specialises in embedded computing for rugged environments. Tri-M's innovative solutions are the premiere choice for off-highway vehicles, industrial controls, robotics, military equipment, aerospace technologies, undersea and advanced security products. We offer a wide range of DC-DC converters, CPU boards, hardened enclosures, I/O modules, wireless communication devices, and customized systems. With over 28 years of industry experience, Tri-M is your embedded systems specialist.

## Who this Guide is For

This user guide is intended for integrators of embedded system applications. It contains detailed information on hardware and software requirements to interconnect to other embedded devices. Carefully read this user guide before you begin installation. The user should be familiar with practicing safe techniques while making supply or pin connections.

## User Guide Revision History

Revision	Date	Description
A	Mar 2012	Added Linux kernel information and ISP pin programming options.
B	Apr 2012	Added CABLESET002 information.

## Trademarks

Trademarks, registered trademarks, and product names are the property of their respective owners and are used herein for identification purposes only.

## Contact Information

Tri-M Technologies Inc.  
101-1530 Kingsway Avenue  
Port Coquitlam, BC V3C 6N6 Canada

Telephone	Toll free North America: 1.800.665.5600 Direct: +1.604.945.9565	
Email	Technical Support	techsupport@tri-m.com
	Sales	sales@tri-m.com
	Information	info@tri-m.com
Website	<a href="http://www.tri-m.com">www.tri-m.com</a>  To submit a request for technical support, please complete the online form at <a href="http://www.tri-m.com/support/contact.html">www.tri-m.com/support/contact.html</a> .  To request an RMA, please complete the online form at <a href="http://www.tri-m.com/support/rma/index.html">www.tri-m.com/support/rma/index.html</a> .	

## Technical Support

Business hours: M–F, 8:30am to 5pm PST

## Warranty

For warranty information, see “Tri-M Technologies Inc. (Limited Warranty)” on page 34.

# Important Safety Instructions

## Conventions Used in this Guide



### Note

This note contains important or useful information in the use or installation of the product.



### CAUTION

The caution provides information to prevent potential equipment damage or shock hazard.

## Electrostatic Discharge (ESD) Precautions

To avoid electrostatic discharge or transient voltage damage to the board, observe the following procedures:

- Before touching the board, discharge your body and any tools you use from electricity.
- Ensure that the board or the unit you want to install the board on is de-energized before installing.
- Do not touch any devices or components on the board.



### CAUTION: Shock Hazard

As soon as the board is connected to a working power supply, touching the board may result in electrical shock, even if the board has not been switched on yet.

# Contents

<b>Important Notes .....</b>	<b>2</b>
Contact Information .....	2
<b>Important Safety Instructions.....</b>	<b>3</b>
Conventions Used in this Guide .....	3
Electrostatic Discharge (ESD) Precautions .....	3
<b>1 Introduction .....</b>	<b>7</b>
Key Specifications .....	7
Models .....	7
Part Number for Cable Set .....	7
Options .....	7
Specifications.....	8
Electrical Specifications .....	8
Mechanical Specifications.....	8
Environmental Specifications.....	8
Communication .....	8
Configuration.....	8
Certifications .....	8
Block Diagram .....	9
Dimensions .....	10
Connector Locations.....	11
<b>2 Connectors .....</b>	<b>12</b>
Connector Specifications .....	12
PC/104 8-bit Bus (CN1).....	12
PC/104 16-bit Bus (CN2).....	13
RS-232 Ports (CN3, CN4, CN5, CN6).....	14
RS-485 Port (CN7) .....	15
JTAG Port (CN8 Top).....	16
USB Port (CN8 Bottom).....	16
LED Port (CN9).....	17
Universal MultiTech Sockets (CN10, CN11) .....	18
CAN Bus (CN12, CN13).....	20

<b>3 Configuration</b> .....	<b>21</b>
Overview .....	21
Command-line Configuration Setup.....	21
Mass Storage Configuration Setup.....	22
Command-line Configuration .....	23
UART 1 .....	24
UART 2 .....	25
UART CLOCK DIVIDER .....	25
SERIAL PORT ENABLE/DISABLE .....	26
DSR.....	26
RS-485.....	27
SOCKET RESET .....	27
CAN BUS MODE .....	28
CAN BUS 1 .....	28
CAN BUS 2 .....	29
HEART BEAT .....	29
TEMP .....	29
ALARM MESSAGE .....	30
CONFIG .....	30
<b>A Appendix</b> .....	<b>31</b>
CABLESET002 .....	31
Serial Cable .....	31
CAN Bus Cable .....	32
Utility Cable .....	32
PGM Config Cable .....	33
<b>Warranty and Product Information</b> .....	<b>34</b>
Tri-M Technologies Inc. (Limited Warranty) .....	34
Disclaimer .....	34
<b>Frequently Asked Questions (FAQ)</b> .....	<b>35</b>

---

## Figures

Figure 1: Block Diagram .....	9
Figure 2: TCB1000 Dimensions.....	10
Figure 3: Connector Locations.....	11
Figure 4: CN1 Connector Pinouts.....	12
Figure 5: CN2 Connector Pinouts.....	13
Figure 6: CN3 to CN6 Connector Pinouts.....	14
Figure 7: CN7 Connector Pinouts.....	15
Figure 8: CN8 Connector Pinouts.....	16
Figure 9: CN9 Connector Pinouts.....	17
Figure 10: Pin 1 on the Universal Sockets.....	18
Figure 11: Pins used on the Universal Sockets .....	19
Figure 12: CN12 and CN13 Connector Pinouts.....	20
Figure 13: TCB1000 accessed using a USB cable as a Virtual COM Port.....	21
Figure 14: TCB1000 accessed via a Stack.....	21
Figure 15: TCB1000 configured as a Mass Storage Device.....	22
Figure 16: Terminal Command-line Application .....	23
Figure 17: Serial Cable .....	31
Figure 18: CAN Bus Cable .....	32
Figure 19: Utility Cable .....	32
Figure 20: PGM Config Cable.....	33

# 1 Introduction

The TCB1000 Series features dual SJA1000 CAN Bus controllers, isolated serial ports, and two MultiTech® Universal compatible sockets on a single PC/104 board design. This high density communication board offers an all-in-one communication solution, optimizing Size, Weight, and Performance (SWaP) requirements for easier system integration. TCB1000 is an industry first, and takes full advantage of the latest technologies in jumperless configuration, high voltage isolation, and advanced communication functionality.

The TCB1000 Series includes advanced networking and configuration capabilities. The 4xRS-232 ports and 1xRS-485 port feature 2500V isolation protection and individual +5VDC isolated power supplies, thus providing less noise and increased system protection. The RS-485 port can be configured as J1708.

With USB connectivity and jumperless setup, extended operating temperature, and versatile options, Tri-M's TCB1000 Series is your perfect choice for CAN Bus, serial, wired, or wireless communication. To learn more about the TCB1000 Series, please contact us at 1-800-665-5600 or visit us at <http://www.tri-m.com/products/trim/tcb1000.html>.

## Key Specifications

- All-in-one PC/104 communication solution for CAN Bus, serial port, wired, and wireless communication (including optional GPS functionality)
- High voltage (2500V) port isolation to reduce noise and increase system protection
- Advanced CAN Bus functionality—such as socket network device operation—adds flexibility to your embedded system to reduce development time, cost, and installation setup
- Jumperless configuration with secure lock, ensuring uniformity and maximizing system security
- Extended operating temperature -40°C to +85°C (-40°F to +185°F), suited for outstanding performance and reliability in harsh environments
- OS support for Linux kernels 2.6.25 and later

## Models

TCB1002	Communications board with 2 isolated CAN Bus controllers
TCB1120	Communications board with 1 isolated RS-485 port, 2 MultiTech Universal Sockets
TCB1400	Communications board with 4 isolated RS-232 ports
TCB1522	Communications board with 4 isolated RS-232 ports, 1 isolated RS-485 port, 2 isolated CAN Bus controllers, and 2 MultiTech Universal Sockets

## Part Number for Cable Set



CABLESET002	Cable set is sold separately. Includes a PGM config cable, serial cable, CAN Bus cable, and utility cable. For more information, see “A Appendix” on page 31.
-------------	---

## Options

- Conformal Coating (Acrylic CH, Acrylic higher voltage CH1, Silicone CS, Urethane CU)  
Ruggedized protection against temperature, fungal resistance, humidity, and chemical.

For more information, please visit our website at <http://www.tri-m.com/products/trim/conformal.html> or call 1.800.665.5600.

## Specifications

<b>Electrical Specifications</b>	
Supply Voltage	+5VDC
Aux Port Output Current	200mA per port
Aux Port Output Isolation	2500V maximum
<b>Mechanical Specifications</b>	
Dimensions	PC/104 compliant
	90 × 96 × 15mm (3.55 × 3.78 × 0.6")
Weight	52g (1.83oz)
<b>Environmental Specifications</b>	
Operating Temperature	-40°C to +85°C (-40°F to +185°F)
<b>Communication</b>	
CAN Bus Controllers	2x NXP SJA1000 Controllers, 1Mbps maximum
RS-232 Ports	4x Isolated Ports, 921Kbp/s maximum
RS-485 Port	1x Isolated Port, 921Kbp/s maximum Can be configured as J1708
Universal Socket Connectivity	2x MultiTech® compatible SocketModem® 921 Kbp/s maximum
LED Indicators	5x Isolated LEDs, built-in limiting resistors
USB/JTAG	1x USB/JTAG Port for easy installation setup
<b>Configuration</b>	
Embedded Design	No jumpers required
USB/JTAG Port	Configuration, CPLD & MCU Programming
PC/104 through UART2 PORT4	Configuration Port
OS Support	Linux kernels 2.6.25 and later
<b>Certifications</b>	
	<p>Tested to MIL-STD-810G. For more information, see the Certificate of Compliance available at <a href="http://www.tri-m.com">www.tri-m.com</a>.</p> <div style="display: flex; align-items: center;">  <p>Manufactured in <b>ISO 9001:2008</b> <b>ISO 14001:2004 &amp;</b> <b>ANSI/ESD S20.20</b> Environments</p> </div> <div style="display: flex; align-items: center; margin-top: 5px;">  <p><b>RoHS</b> compliant</p> </div>



## Block Diagram

Figure 1 shows a block diagram of the TCB1000.

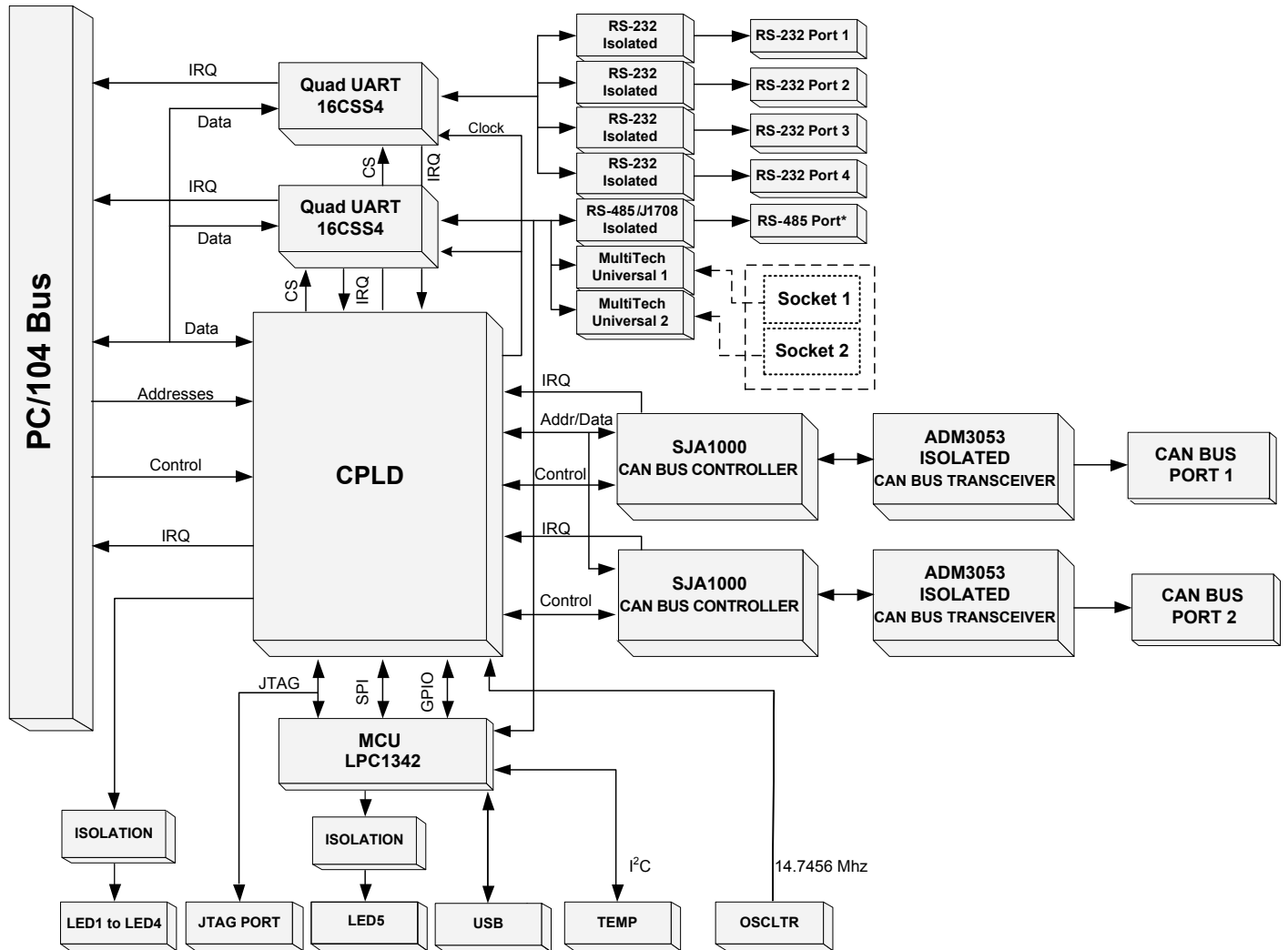

\*The RS-485 port can be configured as J1708.

Figure 1: Block Diagram



### Note

For technical reference only.

## Dimensions

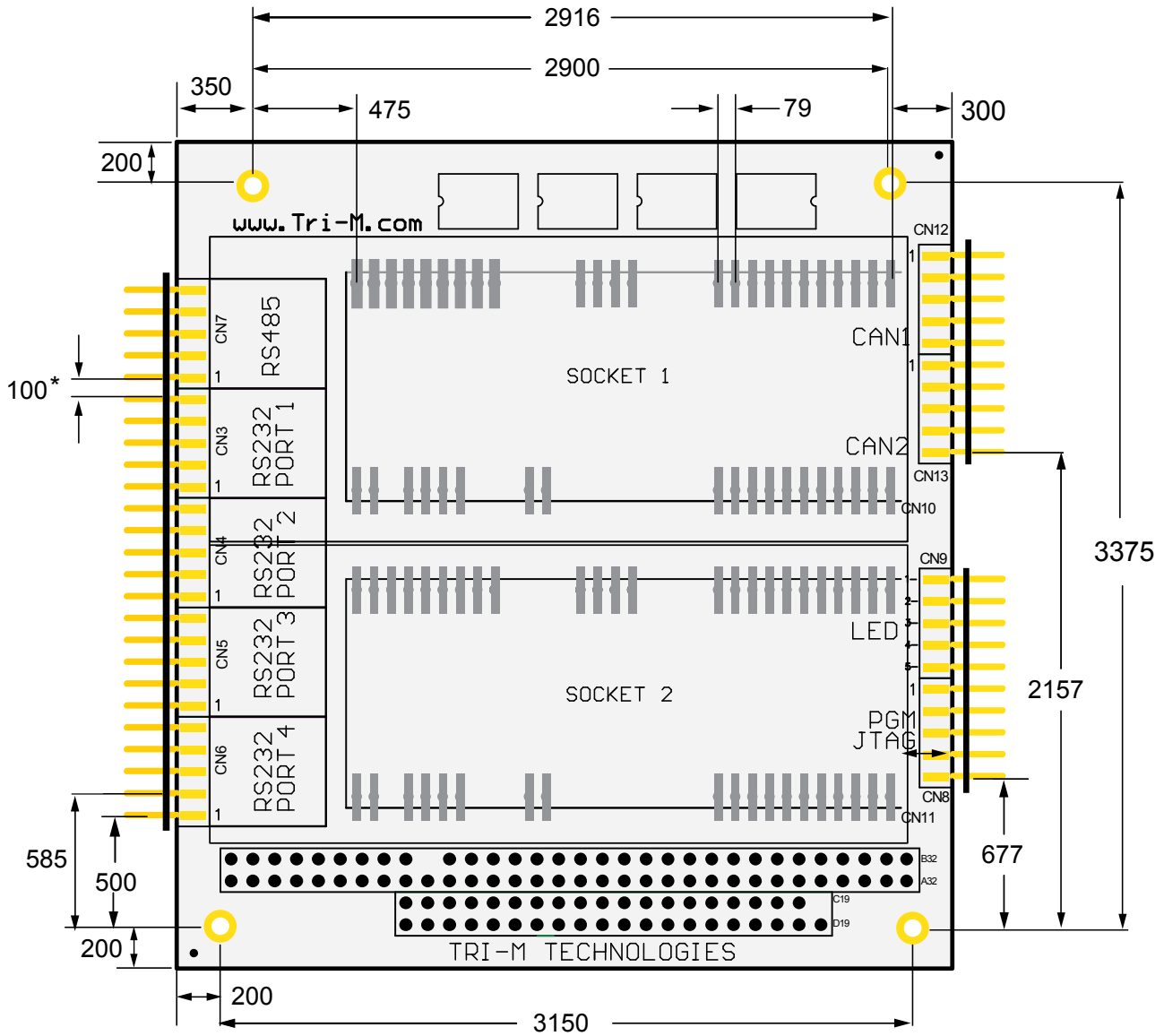

Figure 2: TCB1000 Dimensions



### Note

Dimensions are in mils. 1000 mils = 1 inch.

\* Pin spacing for the connectors (CN3, CN4, CN5, CN6, CN7, CN8, CN9, CN12, and CN13) is 100 mils.

## Connector Locations

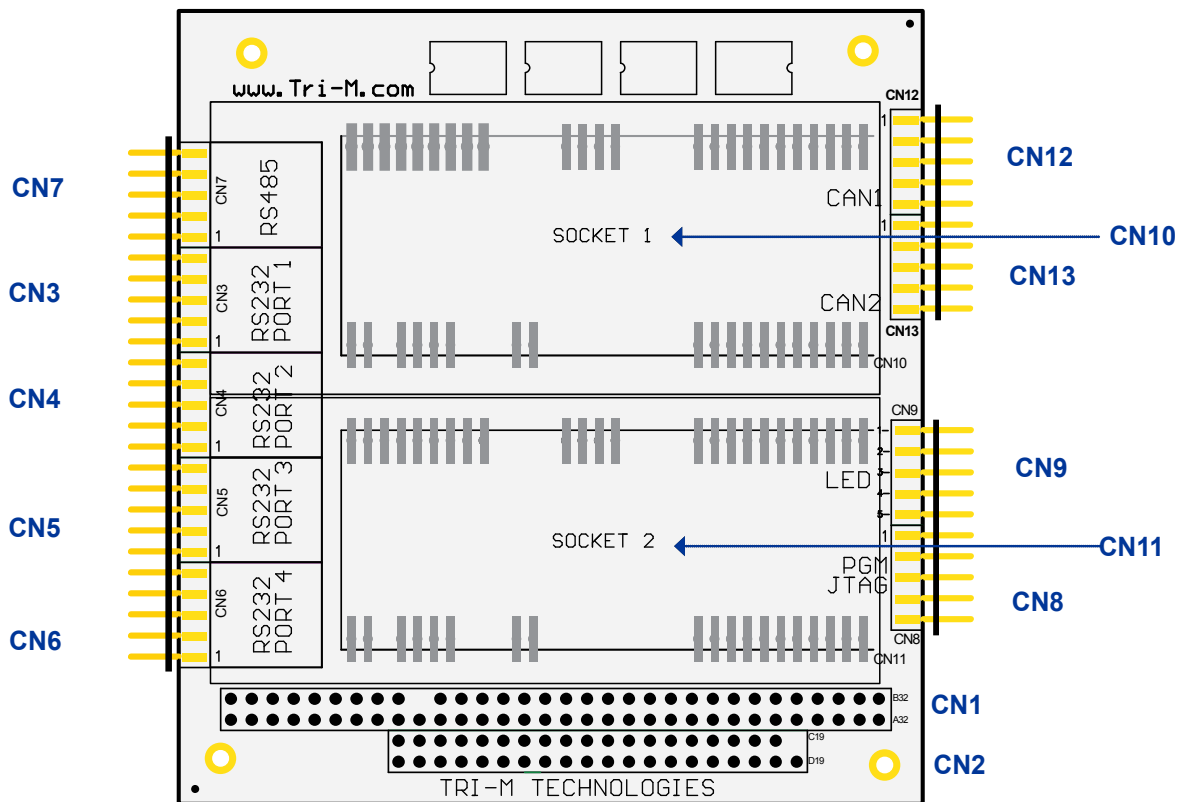

Figure 3: Connector Locations

Label	Connector	Description	Page
CN1	PC/104 8-bit Bus	2x32 press-fit header	See page 12.
CN2	PC/104 16-bit Bus	2x20 press-fit header	See page 13.
CN3	RS-232 Port 1	2x5 right-angle shroud 0.1" pins	See page 14.
CN4	RS-232 Port 2		
CN5	RS-232 Port 3		
CN6	RS-232 Port 4		
CN7	RS-485 Port	2x5 right-angle shroud 0.1" pins Can be configured as J1708.	See page 15.
CN8	JTAG/USB Port	2x5 right-angle 0.1" pins (2) (Top/Bottom)	See page 16.
CN9	5 Isolated LEDs	2x5 right-angle shroud 0.1" pins	See page 17.
CN10	Socket Port 1	Supports Tri-M and Universal MultiTech Modules	See page 18.
CN11	Socket Port 2		
CN12	CAN Bus 1	2x5 right-angle shroud 0.1" pins	See page 20.
CN13	CAN Bus 2		

## 2 Connectors

### Connector Specifications

The following sections describe the mechanical and pinout specifications. For configuration and setup information, please see page 21.

#### PC/104 8-bit Bus (CN1)

CN1 is a PC/104 ISA 8-bit bus with pass-through connectors. Tri-M also accommodates non-pass through and non-PC/104 compliant customisations.



Figure 4: CN1 Connector Pinouts

PC/104 8-bit Connector (CN1)							
Pin	Signal	Pin	Signal	Pin	Signal	Pin	Signal
A1	/IOCHCK	B1	GND	A17	SA14	B17	/DACK1
A2	SD7	B2	RESETDRV	A18	SA13	B18	DRQ1
A3	SD6	B3	+5V	A19	SA12	B19	/REFRESH
A4	SD5	B4	IRQ9	A20	SA11	B20	SYSCLK
A5	SD4	B5	-5V	A21	SA10	B21	IRQ7
A6	SD3	B6	DRQ2	A22	SA9	B22	N/A
A7	SD2	B7	-12V	A23	SA8	B23	IRQ5
A8	SD1	B8	/OWS	A24	SA7	B24	IRQ4
A9	SD0	B9	+12V	A25	SA6	B25	IRQ3
A10	IOCHRDY	B10	GND	A26	SA5	B26	/DACK2
A11	AEN	B11	/SMEMW	A27	SA4	B27	TC
A12	SA19	B12	/SMEMR	A28	SA3	B28	BALE
A13	SA18	B13	/IOW	A29	SA2	B29	+5V
A14	SA17	B14	/IOR	A30	SA1	B30	OSC
A15	SA16	B15	DACK3	A31	SA0	B31	GND
A16	SA15	B16	DRQ3	A32	GND	B32	GND

## PC/104 16-bit Bus (CN2)

CN2 is a 16-bit bus with pass-through connectors. Tri-M also accommodates non-pass through and non-PC/104 compliant customisations.



Figure 5: CN2 Connector Pinouts

PC/104 16-bit Connector (CN2)			
Pin	Signal	Pin	Signal
C0	GND	D0	GND
C1	/SBHE	D1	/MEMCS16
C2	LA23	D2	/IOCS16
C3	LA22	D3	IRQ10
C4	LA21	D4	IRQ11
C5	LA20	D5	IRQ12
C6	LA19	D6	IRQ15
C7	LA18	D7	IRQ14
C8	LA17	D8	/DACK0
C9	/MEMR	D9	DRQ0
C10	/MEMW	D10	/DACK5
C11	SD8	D11	DRQ5
C12	SD9	D12	/DACK6
C13	SD10	D13	DRQ6
C14	SD11	D14	/DACK7
C15	SD12	D15	DRQ7
C16	SD13	D16	+5V
C17	SD14	D17	/MASTER
C18	SD15	D18	GND
C19	GND	D19	GND

### RS-232 Ports (CN3, CN4, CN5, CN6)

CN3 to CN6 are the RS-232 ports 1 to 4. The ports have a maximum baud rate of 921Kbp/s and are galvanically isolated up to 2500V. The isolated ports reduce noise and increase system protection.

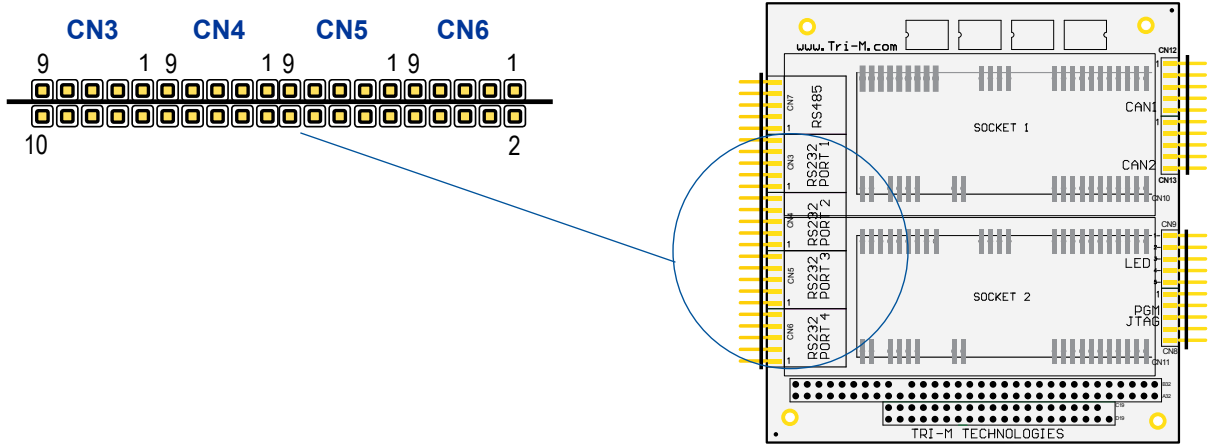

Figure 6: CN3 to CN6 Connector Pinouts

RS-232 Ports 1 to 4 (CN3, CN4, CN5, CN6)			
Top		Bottom	
Pin	Signal	Pin	Signal
1	NC	2	NC
3	RX	4	RTS
5	TX	6	CTS
7	NC	8	NC
9	GNDISO*	10	VCC5VISO*



**Note**

Each port is independently isolated. Pin 9 \*GNDISO and pin 10 VCC5VISO are independently isolated from all other ports.

## RS-485 Port (CN7)

CN7 is the RS-485 port. The port has a maximum baud rate of 921Kbp/s and is galvanically isolated up to 2500V to reduce noise and increases system protection. It also has a terminating 120Ω resistor setting which can be set to open or closed.

The RS-485 port can be configured as J1708. See the table for pin information.

For more on configuring the RS-485 port, see “RS-485” on page 27.

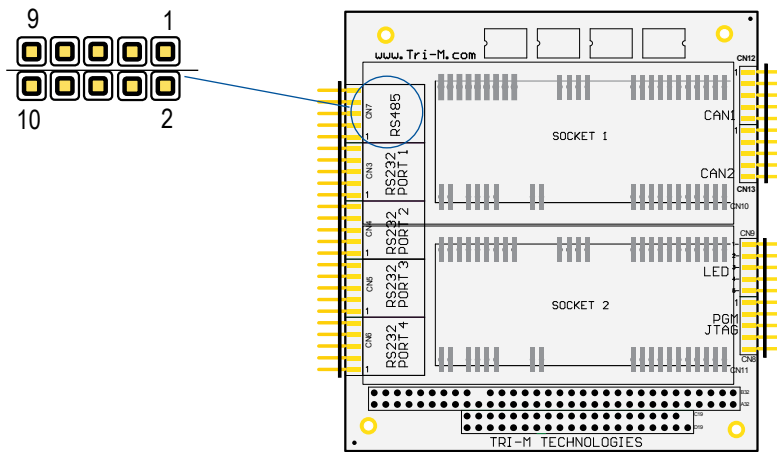

Figure 7: CN7 Connector Pinouts

RS-485 Port (CN7)			
Top		Bottom	
Pin	Signal	Pin	Signal
1	J1708+	2	J1708-
3	RX+	4	TX+
5	TX-	6	RX-
7	NC	8	Z120Ω Enable
9	GNDISO	10	VCC5VISO

**Note**  
The RS-485 must be wired in half-duplex to be able to use the J1708 pins. Connect TX+ to RX+ and connect TX- to RX-.

**Note**  
The software configuration command RSZ will take precedence when set and RSZ takes precedence on the cable configuration. See “SERIAL PORT ENABLE/DISABLE” on page 26 for more information.

## JTAG Port (CN8 Top)

CN8 has two 1x5 headers. The JTAG port provides programming capabilities for the CPLD.

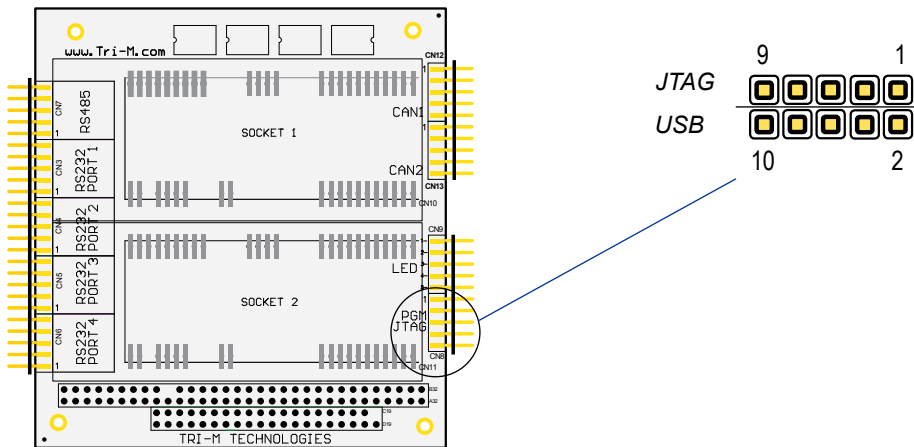

Figure 8: CN8 Connector Pinouts

JTAG Port (CN8)	
Pin	Signal
1	VCC3V3
3	TMS
5	TCK
7	TDI
9	TDO



### Note

The JTAG port is for factory use only.

## USB Port (CN8 Bottom)

The USB port is used to set up and configure the TCB1000.

USB Port (CN8)	
Pin	Signal
2	VCCUSB
4	D-
6	D+
8	GND
10	ISP*



### Note

\*Connecting the ISP to ground puts the USB port in firmware replacement mode.

Leaving the ISP pin unconnected lets you edit the settings using the config.txt file.

The 'config.txt' files will be overwritten if the 'firmware.bin' is entirely rewritten, and the disk containing the config.txt resides in the upper 4KB of the 'firmware.bin'.



## LED Port (CN9)

CN9 has the five LED Ports. The ports use the respective isolated power. Each port is independently isolated up to 2500V, and does not require any limiting resistors, allowing you to directly connect an LED to the port.

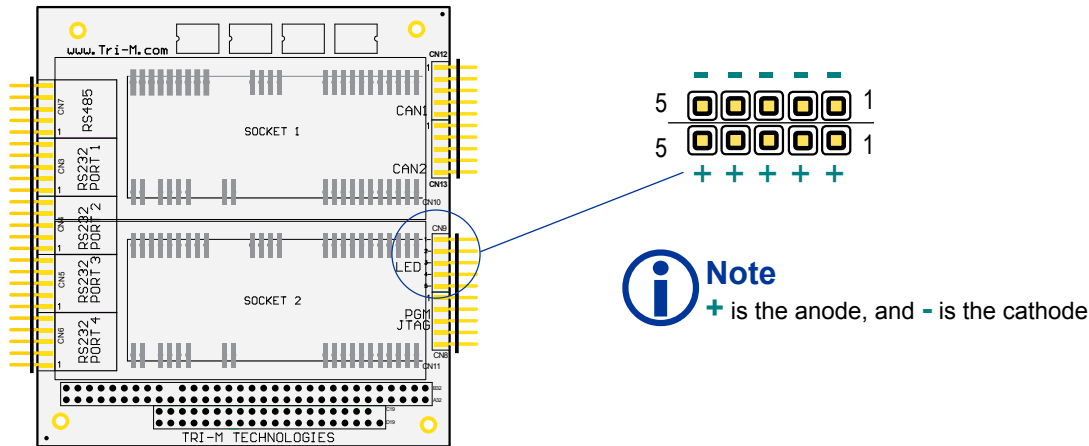

Figure 9: CN9 Connector Pinouts

LED Port (CN9)					
LED	Top		Bottom		Description
	Pin	Signal	Pin	Signal	
LED1	1	LED-	1	LED+	<ul style="list-style-type: none"> <li>LED1 shows the status/activity of a network module inserted in socket 1.</li> <li>It is powered by the RS-232 port 1 isolated power.</li> </ul>
LED2	2	LED-	2	LED+	<ul style="list-style-type: none"> <li>LED2 shows the status/activity of a network module inserted in socket 2.</li> <li>It is powered by the RS-232 port 2 isolated power.</li> </ul>
LED3	3	LED-	3	LED+	<ul style="list-style-type: none"> <li>LED3 is controlled by the GPI04 pin of socket 2.</li> <li>It is powered by the RS-232 port 3 isolated power.</li> </ul>
LED4	4	LED-	4	LED+	<ul style="list-style-type: none"> <li>LED4 shows if the UART is operating at high speed clock = 14.7456MHz or low speed = 1.8432MHz.</li> <li>It is powered by the RS-232 port 4 isolated power.</li> </ul>
LED5	5	LED-	5	LED+	<ul style="list-style-type: none"> <li>LED5 is the CPU heart beat.</li> <li>It is powered by the RS-485 isolated power.</li> </ul>

**Note** The LEDs are independently isolated from each other, and the LEDs will automatically be disabled if the respective serial port is turned off. The LEDs cannot be configured.

## Universal MultiTech Sockets (CN10, CN11)

The Universal MultiTech compatible sockets are capable of serial and wireless or wired communication. Tri-M developed its own GPS module and provides a variety of socket modules including Ethernet, CDMA, GSM, GPRS, Wi-Fi® and Bluetooth®. For specific product information, please visit <http://www.tri-m.com/products/multitech/>.

Figure 10 shows the location of pin 1 on the universal sockets.

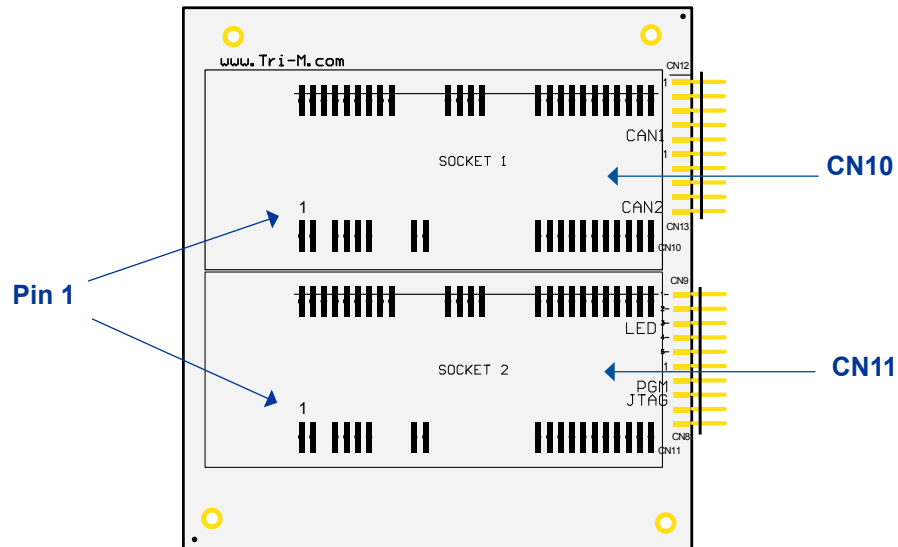
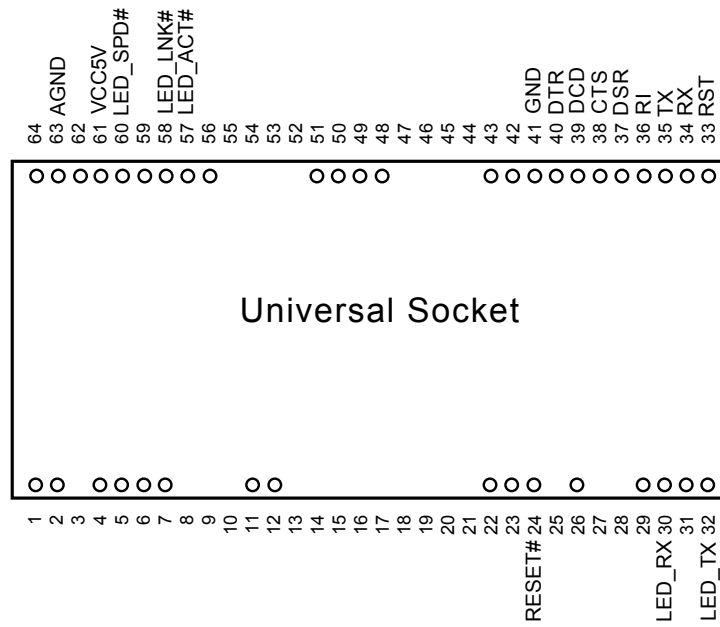

Figure 10: Pin 1 on the Universal Sockets

Figure 11 and the table provide a list of the pins used on the sockets.



**Figure 11: Pins used on the Universal Sockets**

Universal Sockets	
Pin	Signal
24	RESET#
30	LED_RX
32	LED_TX
33	RST
34	RX
35	TX
36	RI
37	DSR
38	CTS
39	DCD
40	DTR
41	GND
57	LED_ACT#
58	LED_LNK#
60	LED_SPD#
61	VCC5V
63	AGND

### CAN Bus (CN12, CN13)

Two NXP SJA1000 CAN Bus controllers are configurable for BasicCAN and PeliCAN. Another feature is the flexibility to access the CAN Bus as a socket network device. To configure the CAN Bus, please see “CAN BUS MODE” on page 28.

The isolated CAN Bus transceivers:

- provide high input impedance for maximum protection in harsh environments. An impedance setting is built into the board and is enabled when pin 6 LOAD ON and pin 7 LOAD T are connected, and unpowered nodes do not disturb the bus resulting in secure and reliable network signaling.
- provide up to 2500V channel isolation, maximum speeds up to 1 Mb/s, and slope control to reduce EMI.
- have thermal shutdown protection.

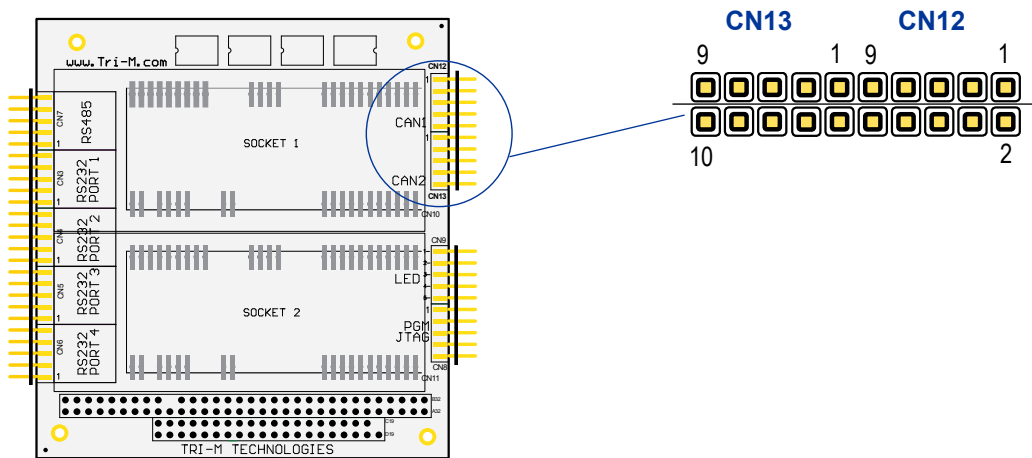

Figure 12: CN12 and CN13 Connector Pinouts

CAN Bus BUS (CN12, CN13)			
Top		Bottom	
Pin	Signal	Pin	Signal
1	N.C.	2	GND ISO
3	CAN Bus-	4	CAN Bus+
5	GND ISO	6	LOAD ON
7	LOAD T	8	+5VDC ISO
9	N.C.	10	N.C.



**Note**

To enable impedance (Z), connect LOAD ON and LOAD T.

## 3 Configuration

### Overview

The configuration setup uses a jumperless embedded design to access the board without having to disassemble and reassemble your stack. The TCB1000 also features a configuration lock to secure your settings from undesirable changes.

There are two methods to configure the TCB1000: command-line configuration setup and mass storage configuration setup. You can access Serial Port 8 (the PC/104 through UART2 PORT4) by connecting a USB cable.

### Command-line Configuration Setup

Connect via USB CDC mode (communication device class) to enable a USB virtual COM Port, as shown in Figure 13. A terminal command-line application is used to configure the device.



**Figure 13: TCB1000 accessed using a USB cable as a Virtual COM Port**

Connect to a stack via the PC/104 through UART2 PORT4 to identify and access the COM Port using a terminal command-line application, as shown in Figure 14.

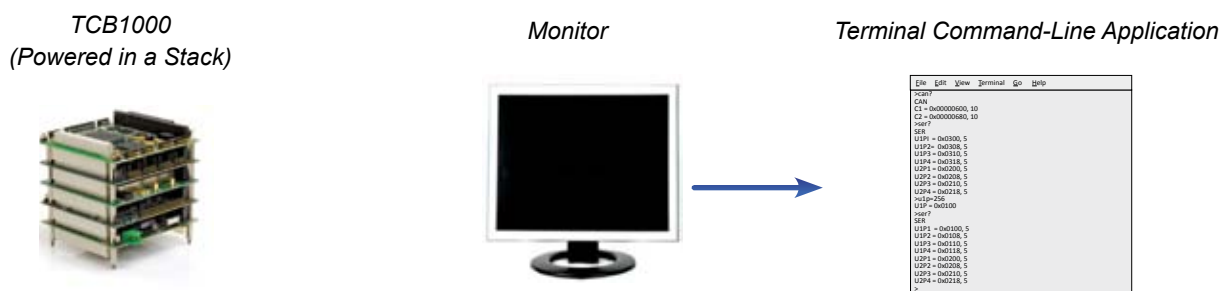

**Figure 14: TCB1000 accessed via a Stack**



**CAUTION**

Locked configuration settings can only be unlocked by accessing the USB virtual COM port in USB CDC (communication device class) mode.

## Mass Storage Configuration Setup

Once you have configured the settings using the command-line configuration setup, lock your configuration profile settings and export to a 'config.txt' file.

Using the USB MSC (mass storage device class) mode, you can transfer the configuration profiles between your PC and the TCB1000, as shown in Figure 15.



Figure 15: TCB1000 configured as a Mass Storage Device



### Note

The TCB1000 does not need to be powered on when connecting the USB cable for mass storage device class mode. It may take up to 25 seconds to identify and mount the device (NXP LPC1342 microcontroller) in programming mode (ISP on) to access the 'firmware.bin'. There is no delay in configuration mode to access the 'config.txt' file.



### CAUTION

Although the device is recognized as a mass storage device, space is limited to approximately 4KB. The intended use is strictly for storing the configuration file, 'config.txt'. The mass storage memory should not be used for any other purpose; if any other files are present, those files will be lost when the system power cycles.

## Command-line Configuration

Once you have established a connection with Serial Port 8 or via USB CDC, use a terminal command-line application, as shown in Figure 16, to read and write values for the commands shown in the table.

```

File Edit View Terminal Go Help
>can?
CAN
C1 = 0x00000600, 10
C2 = 0x00000680, 10
>ser?
SER
U1P1 = 0x0300, 5
U1P2= 0x0308, 5
U1P3 = 0x0310, 5
U1P4 = 0x0318, 5
U2P1 = 0x0200, 5
U2P2 = 0x0208, 5
U2P3 = 0x0210, 5
U2P4 = 0x0218, 5
>u1p=256
U1P = 0x0100
>ser?
SER
U1P1 = 0x0100, 5
U1P2 = 0x0108, 5
U1P3 = 0x0110, 5
U1P4 = 0x0118, 5
U2P1 = 0x0200, 5
U2P2 = 0x0208, 5
U2P3 = 0x0210, 5
U2P4 = 0x0218, 5
>

```

**Figure 16: Terminal Command-line Application**

Command	Description	Page
UART 1	Configures UART1 which controls the RS-232 ports 1 to 4.	See page 24.
UART 2	Configures UART2 which controls the RS-485 port, Socket Modem 1, Socket Modem 2, and the CPU.	See page 25.
UART CLOCK DIVIDER	Assigns a divider value for the UART Clock (f=14.7456MHz).	See page 25.
SERIAL PORT ENABLE/ DISABLE	<ul style="list-style-type: none"> <li>Enables or disables the four RS-232 ports and RS-485 port.</li> <li>Assigns Serial Port 8 to connect to the CPU or GPIO pins on Universal Socket 2.</li> </ul>	See page 26.
DSR	Configures the DSR signal to the DTR for the four RS-232 ports and the RS-485 port.	See page 26.
RS-485	Configures the RS-485 transmit and receive lines.	See page 27.
SOCKET RESET	Manually resets Socket 1 or Socket 2.	See page 27.
CAN BUS MODE	<ul style="list-style-type: none"> <li>Configures CAN Bus for BASIC or PeliCAN, PORTIO or MEMIO.</li> <li>Assigns the same IRQ for both CAN Bus controllers.</li> </ul>	See page 28.
CAN BUS 1	Configures the IRQ, addresses, and slew rate for CAN Bus controller 1.	See page 28.
CAN BUS 2	Configures the IRQ, addresses, and slew rate for CAN Bus controller 2.	See page 29.
HEART BEAT	Assigns a heart beat frequency (in deci-Hertz, 1/10Hz) and duty cycle.	See page 29.
TEMP	Configures the on-board low and high temperature limits in Kelvin.	See page 29.
ALARM MESSAGE	Sets the frequency of the alarm message in second(s).	See page 30.
CONFIG	View the configuration settings, apply the changes, save/load the configuration profile (Config.txt), lock any configuration changes.	See page 30.

## UART 1

These commands allow you to configure UART1 which controls the RS-232 ports 1 to 4.

Read Command	Description
SER?	Displays the addresses and IRQs used by UART1 and UART2.
U1?	Displays the addresses and IRQs used by UART1.
U1P?	Displays the addresses used by UART1.
U1P1?	Displays the address used by UART1 Port 1 (RS-232 Port 1).
U1P2?	Displays the address used by UART1 Port 2 (RS-232 Port 2).
U1P3?	Displays the address used by UART1 Port 3 (RS-232 Port 3).
U1P4?	Displays the address used by UART1 Port 4 (RS-232 Port 4).
U1I?	Displays the IRQ used by UART1.
U1I1?	Displays the IRQ used by UART1 Port 1 (RS-232 Port 1).
U1I2?	Displays the IRQ used by UART1 Port 2 (RS-232 Port 2).
U1I3?	Displays the IRQ used by UART1 Port 3 (RS-232 Port 3).
U1I4?	Displays the IRQ used by UART1 Port 4 (RS-232 Port 4).



### Note

To enter a Read Command using a terminal command-line application, type the command exactly as shown in the Read Command column. For instance, type **SER?**, then press the **Enter key** to return the value.

Write Command	Value	Default	Description
U1P=	The ADDRESS RANGE is from 0x100 to 0x3E0 by steps of 0x20. For instance, 0x100, 0x120...0x3C0, 0x3E0.	0x100	Assign a base address to UART1. The value should represent the real 10bits value as it will be masked with 0x3E0.
U1I=	IRQ (5, 6, 7, 10, 11, 12, 15)	5	Assign an IRQ.



### Note

ADDRESS values can be entered in decimal or hexadecimal.



## UART 2

These commands allow you to configure UART2, which controls the RS-485 port, Socket Modem 1, Socket Modem 2, and CPU.

Read Command	Description
SER?	Displays the addresses and IRQs used by UART1 and UART2.
U2?	Displays the addresses and IRQ used by UART2.
U2P?	Displays the addresses used by UART2.
U2P1?	Displays the address used by UART2 Port 1 (RS-485 port).
U2P2?	Displays the address used by UART2 Port 2 (Socket 1).
U2P3?	Displays the address used by UART2 Port 3 (Socket 2.)
U2P4?	Displays the address used by UART1 Port 4 (CPU).
U2I?	Displays the IRQ used by UART2.
U2I1?	Displays the IRQ used by UART2 Port 1 (RS-485 port).
U2I2?	Displays the IRQ used by UART2 Port 2 (Socket 1).
U2I3?	Displays the IRQ used by UART2 Port 3 (Socket 2).
U2I4?	Displays the IRQ used by UART1 Port 4 (CPU).



### Note

Write Commands take effect when you enter the **UPD** command and are saved with the **STD** command. The configuration settings are then saved to config.txt located on the mass storage device.

Write Command	Value	Default	Description
U2P=	ADDRESS (in Hexadecimal) The ADDRESS RANGE is from 0x200 to 0x3E0 by steps of 0x20. For instance, 0x100, 0x120...0x3C0, 0x3E0.	0x200	Assign a base address to UART2. The value should represent the real 10bits value as it will be masked with 0x3E0.
U2I=	IRQ (5, 6, 7, 10, 11, 12, 15)	5	Assign an IRQ.



### Note

If you enter an invalid Value, a 'value out of range' message will appear and the default value will be used instead.

## UART CLOCK DIVIDER

These commands allows you to assign a divider value for the UART Clock (f=14.7456MHz).

Read Command	Description
UCD?	Displays the value of the divider for the UART Clock.

Write Command	Value	Default	Description
UCD=	F or S	F	UART clock divider setting F=FAST (14.7456MHz), S=SLOW (1.8432MHz)

## SERIAL PORT ENABLE/DISABLE

These commands allow you to enable or disable the four RS-232 ports and the RS-485 port. You can also assign Serial Port 8 to be connected to the CPU or GPIO pins on the Universal Socket 2. Note that disabling the ports will also affect the power of the LEDs.

Read Command	Description
RS1?	Displays the Enable/Disable status of Serial Port 1 (RS-232 Port 1).
RS2?	Displays the Enable/Disable status of Serial Port 2 (RS-232 Port 2).
RS3?	Displays the Enable/Disable status of Serial Port 3 (RS-232 Port 3).
RS4?	Displays the Enable/Disable status of Serial Port 4 (RS-232 Port 4).
RS5?	Displays the Enable/Disable status of Serial Port 5 (RS-485 Port).
RS8?	Displays whether the CPU or Socket 2 is connected to Serial Port 8 (UART 2 Port 4).
RSZ?	Displays the Terminated/Open status of Serial Port 5 (RS-485 port).

Write Command	Value	Default	Description
RS1=	E or D	E	Enable or disable Serial Port 1 (RS-232 Port 1).
RS2=	E or D	E	Enable or disable Serial Port 2 (RS-232 Port 2).
RS3=	E or D	E	Enable or disable Serial Port 3 (RS-232 Port 3).
RS4=	E or D	E	Enable or disable Serial Port 4 (RS-232 Port 4).
RS5=	E or D	E	Enable or disable Serial Port 5 (RS-485 Port).
RS8=	C or S	C	Assigns the CPU or Socket 2 to be connected to Serial Port 8.
RSZ=	T or O	O	Connect (T) / disconnect (O) the Serial Port 5 termination (RS-485 Port).

## DSR

These commands allow you to configure the DSR signal to the DTR for the four RS-232 ports and the RS-485 port.

Read Command	Description
DSR1?	Displays the Connect/Disconnect DSR signal of Serial Port 1 (RS-232 Port 1) to DTR.
DSR2?	Displays the Connect/Disconnect DSR signal of Serial Port 2 (RS-232 Port 2) to DTR.
DSR3?	Displays the Connect/Disconnect DSR signal of Serial Port 3 (RS-232 Port 3) to DTR.
DSR4?	Displays the Connect/Disconnect DSR signal of Serial Port 4 (RS-232 Port 4) to DTR.
DSR5?	Displays the Connect/Disconnect DSR signal of Serial Port 5 (RS-485 Port) to DTR.

Write Command	Value	Default	Description
DSR1=	C or D	D	Connect/Disconnect the DSR signal of Serial Port 1 (RS-232 Port 1) to DTR.
DSR2=	C or D	D	Connect/Disconnect the DSR signal of Serial Port 2 (RS-232 Port 2) to DTR.
DSR3=	C or D	D	Connect/Disconnect the DSR signal of Serial Port 3 (RS-232 Port 3) to DTR.
DSR4=	C or D	D	Connect/Disconnect the DSR signal of Serial Port 4 (RS-232 Port 4) to DTR.
DSR5=	C or D	D	Connect/Disconnect the DSR signal of Serial Port 5 (RS-485 Port) to DTR.

## RS-485

These commands allow you to configure the RS-485 transmit and receive lines.

Read Command	Description
TXI?	Displays the TXDI connection (RS-485 Transmit line), TXD or GND.
TXE?	Displays the TXDE connection (RS-485 Transmit enable), RTS or !TXD.
RXE?	Displays the RXDE connection (RS-485 Receive enable) ALWAYS or when not transmitting (!TXDE).
CTS?	Displays the connection of Serial Port 5 (RS-485), RTS or CONTROLLED (by the CPU).
DLY?	Returns the controlled delay assigned to the CTS of Serial Port 5 (RS-485) in 1/10 ms.

Write Command	Value	Default	Description
TXI=	T or G	T	Assigns the TXDI connection (RS-485 Transmit line) to TXD or GND.
TXE=	R or T	R	Assigns the TXDE connection (RS-485 Transmit enable) to RTS (R) or !TXD (T).
RXE=	A or T	A	Assigns the RXDE connection (RS-485 Receive enable) to ALWAYS or when not transmitting (!TXDE).
CTS=	R or C	R	Assigns the connection of Serial Port 5 (RS-485) to RTS or CONTROLLED (by the CPU).
DLY=	The time range is from 0 to 4095 and stated in 1/10 of a ms.	100	Assigns the controlled delay assigned to CTS of Serial Port 5 (RS-485) in 1/10 ms.

## SOCKET RESET

These commands allow you to manually reset Socket 1 or Socket 2. S1R and S2R do not require the UPD command to be activated.

Read Command	Description
S1R?	Displays the Reset status of Socket 1, Yes or No.
S2R?	Displays the Reset status of Socket 2, Yes or No.

Write Command	Value	Default	Description
S1R=	Y or N	N	Manually resets Socket 1.
S2R=	Y or N	N	Manually resets Socket 2.



### Note

If the socket is reset, S1R=Y, it will remain in reset mode until S1R=N is entered.

## CAN BUS MODE

These commands allow you to configure the CAN Bus for BASIC or PeliCAN, PORTIO or MEMIO, and assign the same IRQ for both CAN Bus controllers.

Read Command	Description
CI?	Displays the IRQ for both CAN Bus controllers.
CD?	Displays the CAN Bus address PORTIO or MEMIO decoding.
CM?	Displays the CAN Bus mode of BASIC or PeliCAN.

Write Command	Value	Default	Description
CI=	IRQ (5, 6, 7, 10, 11, 12, 15)	10	Assigns an IRQ for both CAN Bus controllers.
CD=	P or M	P	Assigns the CAN Bus address decoding to PORTIO or MEMIO.
CM=	B or P	P	Assigns the CAN Bus mode to BASIC or PeliCAN.



### Note

If the address is encoded on 20bits the IOMEM bit is set. If the address is encoded on 16bits or less the IOMEM bit is cleared.

## CAN BUS 1

These commands allow you to configure the IRQ, addresses, and the slew rate for CAN Bus controller 1.

Read Command	Description
CAN Bus?	Displays the address and IRQ for both CAN Bus controllers.
C1?	Displays the address and IRQ used by CAN Bus controller 1.
C1P?	Displays the address used by CAN Bus controller 1.
C1I?	Displays IRQ used by CAN Bus controller 1.
C1S?	Displays the Slew Rate for CAN Bus controller 1, FAST or SLOW.

Write Command	Value	Default	Description
CP=	ADDRESS	0x600(1)	Assigns the base address for both CAN Bus controllers.
C1I=	IRQ (5, 6, 7, 10, 11, 12, 15)	10	Assigns an IRQ to CAN Bus controller 1.
C1S=	F or S	F	Assigns the Slew Rate for CAN Bus controller 1, FAST or SLOW.



### Note

If BASIC CAN Bus: CAN2 address= CAN1 address + 0x20, if PeliCAN CAN2 address= CAN1 address + 0x80.

## CAN BUS 2

These commands allow you to configure the IRQ, addresses, and slew rate for the CAN Bus controller 2.

Read Command	Description
CAN Bus?	Displays the address and IRQ used by both CAN Bus controllers.
C2?	Displays the address and IRQ used by CAN Bus controller 2.
C2P?	Displays the address used by the CAN Bus controller 2.
C2I?	Displays IRQ used by the CAN Bus controller 2
C2S?	Displays the Slew Rate for CAN Bus controller 2, FAST or SLOW.

Write Command	Value	Default	Description
CP=	ADDRESS	0x600(2)	Assigns the base address for both CAN Bus controllers.
C1I=	IRQ (5, 6, 7, 10, 11, 12, 15)	5	Assigns an IRQ to CAN Bus controller 2.
C1S=	F or S	F	Assigns the Slew Rate for CAN Bus controller 2, FAST or SLOW.



### Note

If BASIC CAN Bus: CAN2 address= CAN1 address + 0x20, if PeliCAN CAN2 address= CAN1 address + 0x80.

## HEART BEAT

These commands allow you to assign a Heart Beat in ms and duty cycle.

Read Command	Description
HBT?	Displays the Heart Beat in ms.
HBD?	Displays the Heart Beat duty cycle in %.

Write Command	Value	Default	Description
HBT=	PERIOD, 1 to 10000ms	2000	Assigns the Heart Beat ms.
HBD=	DUTY CYCLE, 0 to 100%.	50	Assigns the Heart Beat duty cycle in %.

## TEMP

These commands allow you to configure the on-board low and high temperature limits in Kelvin.

Read Command	Description
TRD?	Returns the current on-board temperature reading in Kelvin.
TAL?	Returns the temperature low limit in Kelvin.
TAH?	Returns the temperature high limit in Kelvin.

Write Command	Value	Default	Description
TAL=	TEMPERATURE, 233 to 273 K	233	Assigns the low limit temperature in Kelvin.
TAH=	TEMPERATURE 323 to 358 K	358	Assigns the high limit temperature in Kelvin.

## ALARM MESSAGE

These commands allow you to set the frequency of the alarm message in seconds(s).

Read Command	Description
AMF?	Displays the frequency of the Alarm Message in seconds(s).

Write Command	Value	Default	Description
AMF=	TIME, 0 (disabled) to 43200 (12 minutes)	60s	Assigns the frequency of the Alarm Message in seconds(s).

## CONFIG

These commands allow you to view the configuration settings. In addition, you can apply changes, save/load the configuration profile (Config.txt) and lock any changes.

Read Command	Description
CFG?	Displays the entire configuration settings.
VER?	Displays the firmware version, revision and build.
RT?	Returns the time the board is running in seconds.
LCK?	Returns the lock status of Serial Port 8.

Write Command	Value	Default	Description
UPD=			Applies the changes live on the running hardware.
STD=			Saves the changes to flash.
RLD=			Reload the configuration profile from flash.
LCK=	L or U	U	Locks any change from Serial Port 8, and can only be unlocked from the USB virtual COM port; it can be pre-locked in 'config.txt'.



### CAUTION

Locked configuration settings can only be unlocked by accessing the USB virtual COM port in USB CDC (communication device class) mode.

# A Appendix

## CABLESET002

CABLESET002 contains four cable sets and should be purchased with any first time purchase of the TCB1000 series.

### Serial Cable

Communication control cable with five DB-9 connectors (male) and a 50-pin IDC connector. The cable length is 12 inches (0.3048m).

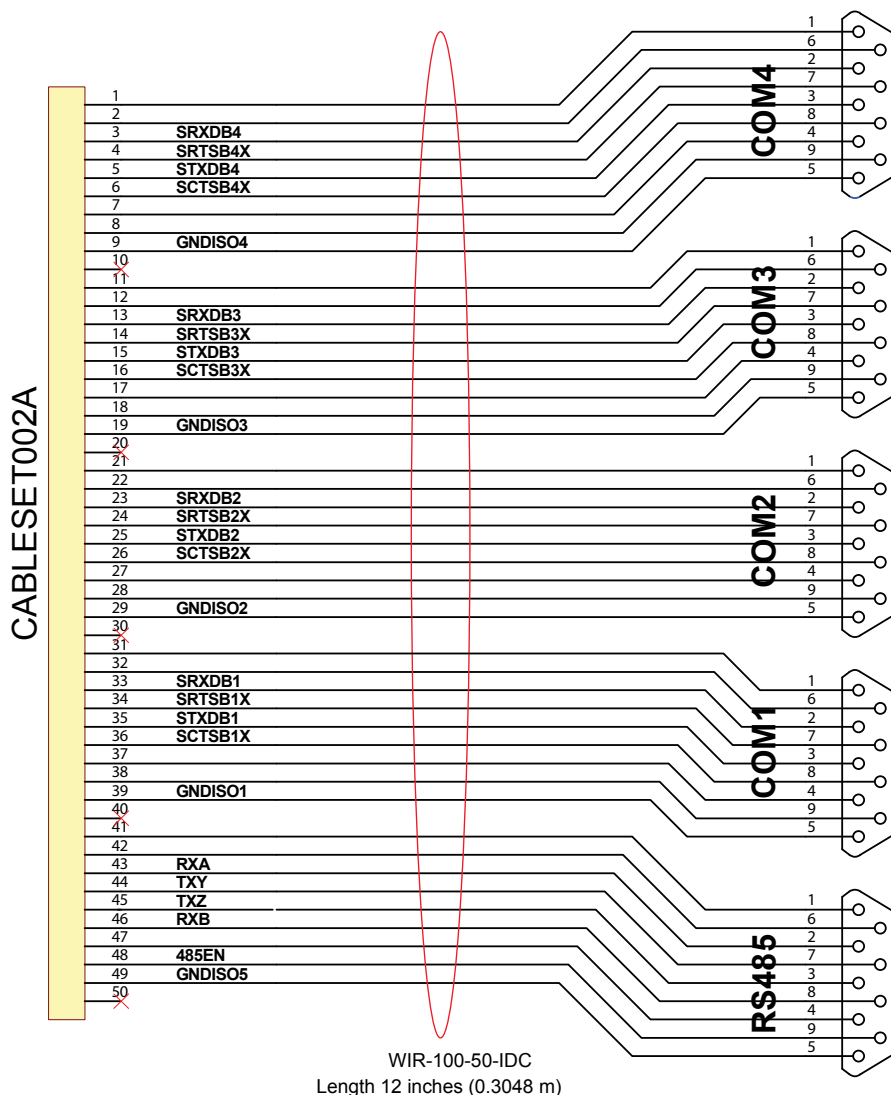

**Figure 17: Serial Cable**

### CAN Bus Cable

Communication control cable with two DB-9 connectors (male) and a 20-pin IDC connector. The cable length is 12 inches (0.3408m).

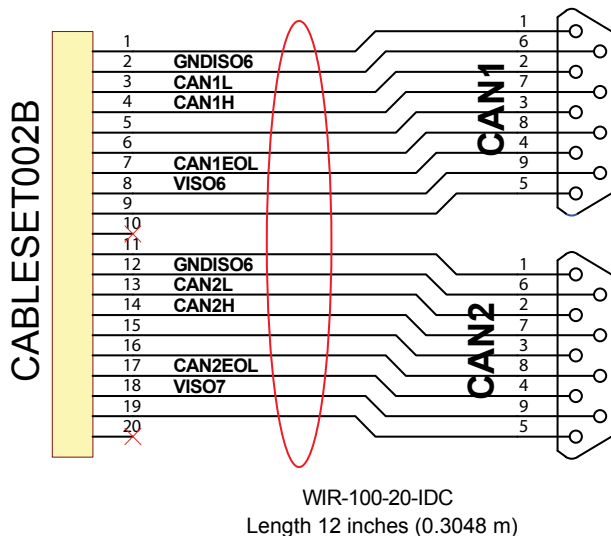

Figure 18: CAN Bus Cable

### Utility Cable

Communication control cable with two 10-pin IDC connectors and a 20-pin IDC connector. The cable length is 12 inches (0.3408m).

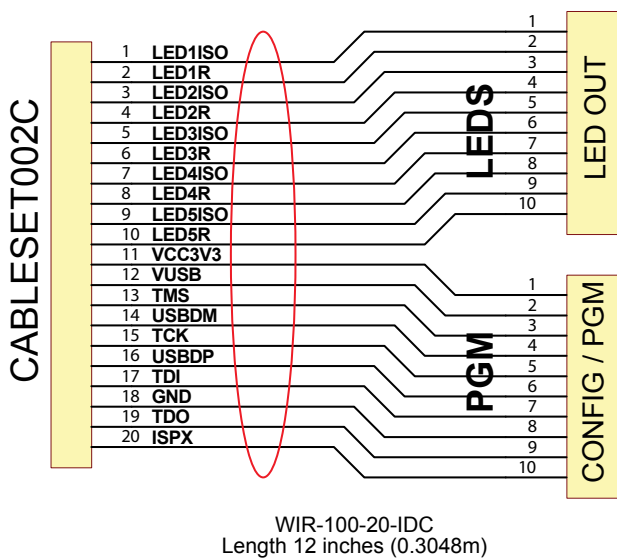
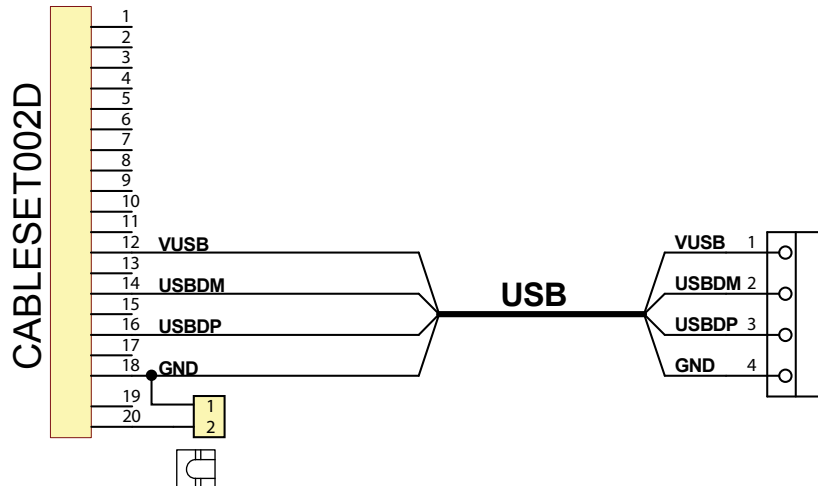

Figure 19: Utility Cable



## PGM Config Cable

Configuration cable with a USB connector and a 20-pin IDC. The USB cable is 6.56 feet (2 meters).



**Note** The jumper between pin 18 and pin 20 allows the use of the cable in configuration/debug mode.  
 Jumper ON: Set the cable to programming mode.  
 Jumper OFF: Set the cable to configuration/debug mode.

**Figure 20: PGM Config Cable**

## Warranty and Product Information

### Tri-M Technologies Inc. (Limited Warranty)

*Unless otherwise agreed to in writing, Tri-M Technologies Inc. (Tri-M) warrants to the original purchaser that its products will be free from defects in material and workmanship for a period of (1) one year from the date of shipment. Tri-M's obligation under this warranty is limited to replacement or repair at its option and its designated site. Any such products must be returned within the warranty period to Tri-M in Tri-M approved packaging with a Tri-M-assigned RMA (Return Material Authorization) number referenced on the shipping documents.*

*All warranties are void if there is evidence of misuse, tampering, or attempted repair of parts. Any returns must be accompanied by a return material authorization (RMA) number issued by Tri-M. Purchaser shall prepay transportation to Tri-M's designated site. If returned products are repaired or replaced under the terms of this warranty, Tri-M shall pay return transportation charges.*

*In no case will Tri-M be held liable for consequential damages arising out of its obligations under this warranty or the failure or incorrect use of any of its products. This warranty is in lieu of all warranties, either express or implied, including, without limitation, any implied warranty of merchantability or fitness for any particular purpose, and of any other obligation on the part of Tri-M.*

### Disclaimer

*No part of this document may be reproduced, transmitted, transcribed, stored in a retrieval system, or translated into any language or computer language, in any form or by any means, electronic, mechanical, magnetic, optical, chemical, manual, or otherwise, without the express written permission of Tri-M Technologies Inc.*

*Tri-M Technologies Inc. (Tri-M) makes no representations or warranties with respect to the contents of this manual, and specifically disclaims any implied warranties of merchantability or fitness for any particular purpose. Tri-M shall under no circumstances be liable for incidental or consequential damages or related expenses resulting from the use of this product, even if it has been notified of the possibility of such damages. Tri-M reserves the right to revise this publication from time to time without obligation to notify any person of such revisions.*

**Copyright © 2012 Tri-M Technologies Inc.**

---

## Frequently Asked Questions (FAQ)

### 1. How many IRQs are used by the 4xRS-232 ports and 1xRS-485 port?

By default, all the serial ports share IRQ5. To assign an IRQ (5, 6, 7, 10, 11, 12, 15), see the Configuration section, “UART 1” on page 24 and “UART 2” on page 25.

### 2. Can one IRQ be shared for all of the serial ports?

Yes, the IRQ can be shared for all the serial ports (4xRS-232 & 1xRS-485).

### 3. If the two socket modems are unpopulated, do they use any IRQ and IOaddr?

Yes, the IRQ and IOaddr resources are assigned to the UART that communicates with the socket modem. See the Configuration section, “UART 1” on page 24 and “UART 2” on page 25.

### 4. What is the IOaddr range used by the 4 or 5 serial ports?

The TCB1000 has 2x4 ports UARTs (UART1 & UART2).

UART1 is dedicated to the RS-232. UART2 is dedicated for the RS-485 and socket modems.

Each UART base address can be configured from 0x100 to 0x3E0 by steps of 0x20. The base address is also the address for the first port of the UART, and the IOaddr of the other three ports automatically follow the first one.

For instance, by default:

UART1 is set to 0x100 meaning that RS-232 port 1 = 0x100, RS-232 port 2 = 0x108, RS-232 port 3 = 0x110, and RS-232 port 4 = 0x118.

UART2 is set to 0x200 meaning that RS-485 = 0x200, Socket 1 = 0x208, Socket 2 = 0x210, onboard-uC = 0x218

Each port is 8 addresses apart because of their 8 internal registers. This is why the UARTs need to be 32 (0x20) addresses apart, in order to provide enough room for all the registers between base addresses.

### 5. What kinds of drivers are available for the CAN Bus and serial functions of the TCB1000, such as DOS, Linux, and Windows®?

The TCB1000 is supported by Linux kernels 2.6.25 and later. The Linux kernel supports the serial port and the CAN Bus. A Windows driver is in development.

### 6. Do the CAN Bus ports use Memory Addressing or IO Addressing under Windows O/S?

The hardware can be configured either using memory or IO addressing.

### 7. Is the TCB Series RoHS Compliant?

All Tri-M's products are RoHs, and we also provide other customisable options depending on your requirements.

### 8. What if I have a technical or specific question?

For technical support, please see “Contact Information” on page 2.