

# SENtral<sup>®</sup>

## Motion Coprocessor

### General Description

The SENtral Motion Coprocessor is a custom integrated circuit that makes it easy to quickly incorporate, optimize and operate multiple motion sensors on mobile consumer electronics devices. SENtral employs and manages a user-specified 3-axis magnetometer, 3-axis accelerometer, and 3-axis gyroscope to provide reliable motion tracking, and accurate heading and orientation data. SENtral gathers data from the individual sensors, then integrates and fuses this data using PNI's proprietary Kalman filtering and heuristic algorithms.

By offloading the sensor fusion and interface from a dedicated sensor hub MCU or the host CPU to SENtral, overall power requirements are dramatically lowered and processing power is opened up for other uses.

These advantages make SENtral the ideal choice for mobile and consumer electronics devices desiring ultra-lower power consumption and best-in-class sensor fusion.

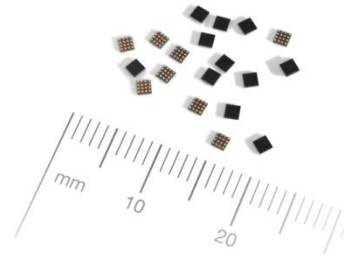

### Features

- Heading Accuracy of 2° rms.
- Ultra Low Power Consumption
- Continuous Soft and Hard-Iron Magnetic Auto-Calibration
- Magnetic Anomaly Compensation
- I<sup>2</sup>C Interface – 100 to 3400 kHz
- Small Form-Factor
- Sensor Flexibility

### Applications

- Cell Phones
- Tablets
- Ultrabooks
- TV Remote Controls
- Video Game Controllers

### Ordering Information

Item	Part #	Quantity	Package
SENtral	13658P	<4000	Cut-Tape
SENtral	13658	4000	Tape & Reel

# Table of Contents

<b>1</b>	<b>PRODUCT OVERVIEW</b> .....	<b>3</b>
1.1	SENTRAL FEATURES AND BENEFITS .....	3
1.2	SENTRAL FUNCTIONAL DESCRIPTION .....	4
<b>2</b>	<b>SENTRAL SPECIFICATIONS<sup>1</sup></b> .....	<b>6</b>
2.1	PERFORMANCE CHARACTERISTICS .....	6
2.2	ELECTRICAL CHARACTERISTICS .....	6
<b>3</b>	<b>LAYOUT</b> .....	<b>8</b>
3.1	SYSTEM LAYOUT .....	8
3.2	PIN ASSIGNMENTS .....	9
3.3	SENSOR LAYOUT .....	10
3.4	DEDICATED EEPROM (OPTIONAL) .....	11
<b>4</b>	<b>I<sup>2</sup>C INTERFACE</b> .....	<b>12</b>
4.1	I <sup>2</sup> C TIMING .....	12
4.2	I <sup>2</sup> C HOST INTERFACE (HOST BUS) .....	13
4.2.1	I <sup>2</sup> C Slave Transfer formats .....	14
4.3	I <sup>2</sup> C SENSOR INTERFACE (SENSOR BUS) .....	15
4.4	I <sup>2</sup> C PULL-UP RESISTANCE .....	15
<b>5</b>	<b>OPERATION</b> .....	<b>16</b>
5.1	POWER-UP AND CONFIGURATION FILE UPLOAD .....	17
5.1.1	Configuration File Upload from EEPROM .....	17
5.1.2	Configuration File Upload from Host .....	19
5.2	INITIAL REGISTER SET-UP .....	20
5.3	RUNNING IN NORMAL OPERATION .....	22
5.3.1	Error .....	24
5.3.2	CPUReset .....	24
5.3.3	Read Results .....	24
5.4	STANDBY STATE .....	25
5.5	PASS-THROUGH STATE .....	26
5.6	TROUBLESHOOTING .....	28
5.6.1	Hardware-Related Error Conditions .....	28
5.6.2	Software-Related Error Conditions .....	28
<b>6</b>	<b>SENTRAL CONFIGURATION TOOL</b> .....	<b>31</b>
6.1	CONFIGURATION TOOL GENERAL SETTINGS .....	32
6.1.1	SDK Revision .....	32
6.1.2	Host Interrupt Pin .....	32
6.1.3	EEPROM Max. Upload Speed .....	32
6.2	CONFIGURATION TOOL SENSOR CONFIGURATION .....	32
6.2.1	Sensor .....	32
6.2.2	Interrupt Pin .....	32
6.2.3	Slave Address .....	32
6.2.4	Orientation Matrix .....	33
6.2.5	Cal Offsets .....	34
<b>7</b>	<b>PACKAGE INFORMATION</b> .....	<b>35</b>
<b>8</b>	<b>ASSEMBLY GUIDELINES</b> .....	<b>37</b>
	<b>APPENDIX I – CONFIGURATION FILE IMAGE FORMAT</b> .....	<b>40</b>
	<b>APPENDIX II – CONVERTING QUATERNIONS</b> .....	<b>42</b>
	<b>APPENDIX III – PARAMETER TRANSFER</b> .....	<b>44</b>
	<b>APPENDIX IV – SAMPLE SCHEMATIC SET</b> .....	<b>50</b>

## List of Figures

Figure 1-1: SENtral Block Diagram .....	4
Figure 3-1: SENtral System Reference Schematic .....	8
Figure 4-1: I <sup>2</sup> C Timing Diagram .....	12
Figure 4-2: I <sup>2</sup> C Slave Write Example .....	14
Figure 4-3: I <sup>2</sup> C Slave Read Example, with Repeated START .....	14
Figure 4-4: I <sup>2</sup> C Slave Write Register Address Only .....	14
Figure 4-5: I <sup>2</sup> C Slave read register from current address .....	14
Figure 5-1: SENtral Initialization Sequence .....	16
Figure 5-2: SENtral Operational States .....	17
Figure 5-3: SENtral Normal Operation Flow .....	23
Figure 6-1: SENtral Configuration Tool .....	31
Figure 7-1: Mechanical Drawing .....	35
Figure 7-2: Tape Dimensions .....	36
Figure 8-1: Typical Solder Mask and Land Pad Parameters .....	38
Figure 8-2: Typical Solder Reflow Profile .....	39
Figure A3-1: Parameter Load Process .....	46
Figure A3-2: Parameter Retrieve Process .....	47

## List of Tables

Table 2-1: Performance Characteristics .....	6
Table 2-2: Absolute Maximum Ratings .....	6
Table 2-3: Operating Conditions .....	7
Table 3-1: SENtral Pin Assignments .....	9
Table 3-2: Recommended Power Line Distance from Magnetometer .....	11
Table 4-1: I <sup>2</sup> C Timing Parameters .....	13
Table 4-2: I <sup>2</sup> C Pull-Up Resistance Table .....	15
Table 5-1: Configuration File Upload from EEPROM Registers .....	18
Table 5-2: Configuration File Host Upload Registers .....	19
Table 5-3: Sample Host Upload Data Order .....	20
Table 5-4: Registers for Initial Set-Up .....	20
Table 5-5: Normal Operation Registers .....	23
Table 5-6: Results Registers .....	25
Table 5-7: Standby Registers .....	25
Table 5-8: Pass-Through Registers .....	27
Table 5-9: Hardware-Related Error Indications .....	28
Table 5-10: Software-Related Error Indications .....	28
Table 5-11: SensorStatus Register Values .....	29
Table 5-12: ErrorRegister Values .....	29
Table 5-13: RAMVersion Register Values .....	30
Table 8-1: Typical Solder Processing Parameters .....	39
Table A1-1: Configuration File Image Format .....	40
Table A1-2: Configuration File Data Structure .....	41
Table A3-1: Registers Used for Parameter Transfer .....	44
Table A3-2: Parameter Numbers .....	48
Table A3-3: DriverID & AlgorithmID Definition .....	49

---

# 1 Product Overview

The SENtral Motion Coprocessor is an integrated circuit that makes it easy to quickly integrate, optimize and operate multiple sensors on mobile consumer electronics devices. SENtral manages and uses data from a user-specified 3-axis gyroscope, 3-axis accelerometer, and 3-axis magnetometer to provide reliable motion tracking and an accurate compass heading, while consuming about 1% of the power of a comparable sensor fusion microprocessor.

---

**Note:** This revision of the SENtral Technical Datasheet applies to Configuration Files of revision 1.1 or higher. The Configuration File is discussed in Sections 1.2, 5.1, 5.6.2, and 6, and [Appendix J](#). It is generated by the SENtral Configuration Tool and is uploaded into SENtral RAM after power up.

---

## 1.1 SENtral Features and Benefits

Features and benefits of the SENtral Motion Coprocessor include:

- **Low power consumption.** Offloads sensor processing from the less efficient host CPU, consuming <1% of the power of a Cortex M0 running a comparable sensor fusion algorithm. Provides the ability to tailor the tradeoff between power consumption and motion-tracking performance.
- **Industry-leading heading accuracy.** Unparalleled heading accuracy for consumer electronics applications.
- **Continuous hard and soft-iron magnetic auto-calibration.** Provides continual background calibration of the sensors. Leverages PNI's more than 20 years of experience and expertise in magnetic measurement.
- **Magnetic anomaly compensation.** Heading and motion tracking is unaffected by magnetic anomalies such as rebar in buildings, desks, speakers etc., that can easily throw off the accuracy. SENtral recognizes and compensates for these anomalies.
- **Sensor flexibility.** Works with common consumer electronic MEMS motion sensors, so system designers can choose the sensors most appropriate for their systems.
- **Small form-factor.** 1.6x1.6x0.5 mm chip-scale package on 0.4 mm pitch. Uses little PCB real estate, allowing for painless integration.
- **I<sup>2</sup>C interface.** Uses the industry-standard I<sup>2</sup>C protocol to interface to the sensors and the host, so system integration is straightforward. Standard, Fast, Fast Plus, and High Speed are supported on the host bus.
- **Outputs.** SENtral outputs quaternions, Euler angles (heading, pitch, & roll), and sensor data (rotational velocity, linear acceleration, & magnetic field).

## 1.2 SENtral Functional Description

Figure 1-1 provides a diagram of SENtral's primary functional blocks, and a brief description of these functional blocks follows.

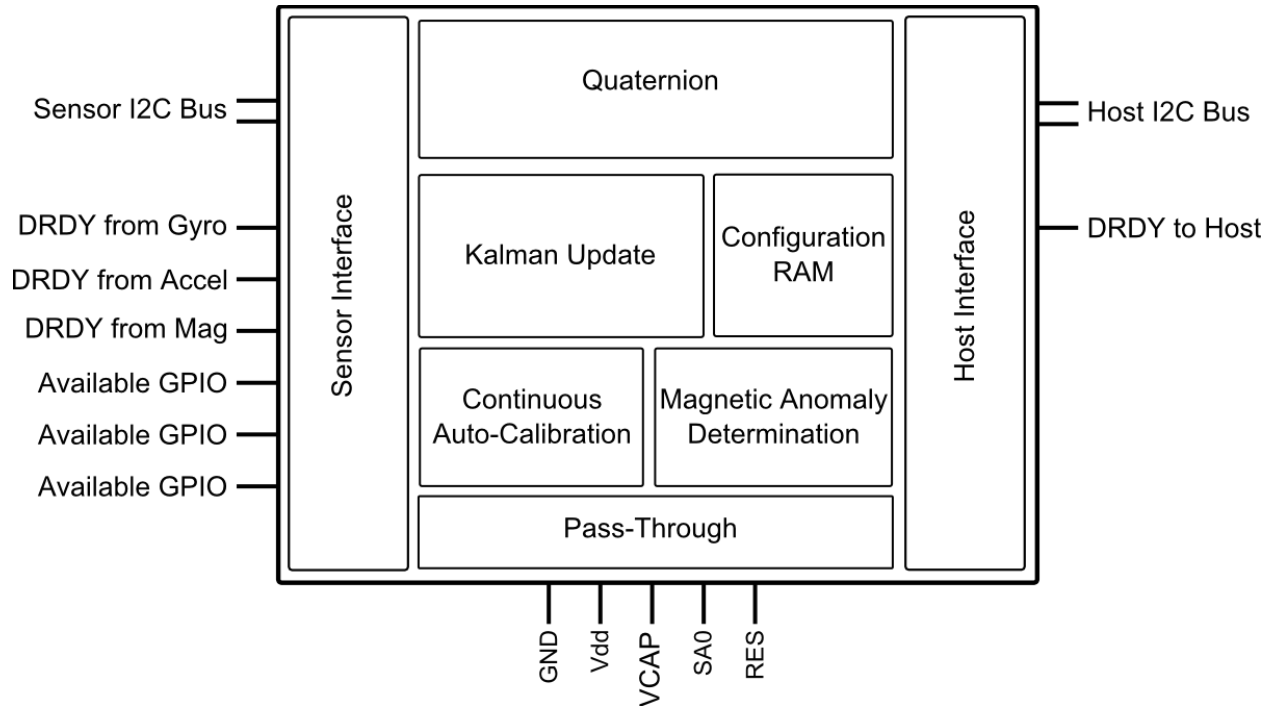

Figure 1-1: SENtral Block Diagram

- **Quaternion** generates the orientation output, where the actual orientation outputs can be quaternions or Euler angles (heading, pitch, & roll). The outputs are updated at a rate limited to the gyro output data rate (ODR), to a maximum of 400 Hz.
- **Kalman Update** fuses data from the 3-axis gyroscope, 3-axis accelerometer, and 3-axis magnetometer, plus data from the magnetic anomaly determination and continuous auto-calibration blocks to generate intelligent orientation updates. The Kalman update involves a sophisticated multi-state Kalman algorithm.
- **Continuous Hard and Soft-Iron Auto-Calibration.** SENtral is the only product in the market that auto-calibrates for both hard-iron and soft-iron magnetic distortions. While others may calibrate for hard-iron distortion, soft-iron distortion is more difficult to correct for, and it can be caused by EMI shielding tape and other shielding materials widely used in mobile and consumer electronic devices. It is important to correct for soft-iron distortions since these can contribute up to 90° of error. Additionally, since a host system's magnetic signature can change over time and temperature, SENtral's continuous auto-calibration ensures accuracy all the time.

- **Magnetic Anomaly Determination** establishes if a transient magnetic distortion is present and accounts for it.
- **Configuration RAM** allows for customizing SENtral to match the specific sensors being used and allows the user to tailor certain parameters for their specific system. The SENtral Configuration Tool generates the SENtral Configuration File, and this is subsequently uploaded into SENtral's Configuration RAM.
- **Pass-Through** allows for direct communication with devices on the sensor bus by connecting SENtral's I<sup>2</sup>C Host Interface to the Sensor Interface.
- **Host Interface** communicates with the host system. Data is transmitted between the host and SENtral via the host I<sup>2</sup>C bus, in which the host acts as the master and SENtral acts as a slave device. SENtral signals the host that new data is available by sending an interrupt signal on the host DRDY line.
- **Sensor Interface** communicates primarily with the sensors. Sensor data is transmitted from the sensors to SENtral via the sensor I<sup>2</sup>C bus, in which SENtral acts as the master and the sensors as the slave devices.

---

## 2 SENtral Specifications<sup>1</sup>

---

### 2.1 Performance Characteristics

Table 2-1: Performance Characteristics

Parameter	Minimum	Typical	Maximum	Units
Heading Accuracy		2		° rms
Output Data Rate		200	400	Hz

---

### 2.2 Electrical Characteristics

Table 2-2: Absolute Maximum Ratings

Parameter	Symbol	Minimum	Maximum	Units	
Supply Voltage	$V_{DD}$	-0.3	+3.6	VDC	
Input Pin Voltage	$V_{IN}$	GND – 0.3	$V_{DD} + 0.3$	VDC	
ESD	Human Body Model	HBM	-2000	+2000	V
	Machine Model	MM	-200	+200	V
Storage Temperature		-50°	+150°	C	

**CAUTION:**

Stresses beyond those listed above may cause permanent damage to the device. These are stress ratings only. Operation of the device at these or other conditions beyond those indicated in the operational sections of the specifications is not implied.

**Footnote**

1. Specifications subject to change.

**Table 2-3: Operating Conditions**

Parameter	Symbol	Min	Typical	Max	Units
Supply Voltage	$V_{DD}$	1.6		3.3	VDC
Power-On Reset Threshold, $V_{REG} > V_{POR}$	$V_{POR}$		$V_{REG} - 0.125$		VDC
High Level Input Voltage	$V_{IH}$	$0.7 \cdot V_{DD}$		$V_{DD}$	VDC
Low Level Input Voltage	$V_{IL}$	0		$0.3 \cdot V_{DD}$	VDC
High Level Output Current, $V_{OH} = V_{DD} - 0.3V$	$I_{OH}$			-1	mA
Low Level Output Current, $V_{OL} = 0.3V$	$I_{OL}$	1			mA
Current Consumption @ $1.8 V_{DD}$	Normal Operation <sup>1</sup>		100 – 300		$\mu A$
	Pass-Through State <sup>2</sup>		45		$\mu A$
	Standby State		7		$\mu A$
$I^2C$ Interface Data Rate <sup>3</sup>	Host Bus			3400	kbits/sec
	Sensor Bus			1000	kbits/sec
	Pass-Through			400	kbits/sec
Decoupling Capacitor (ESR $< 2\Omega$ )	$C_{reg}$	0.33	0.5	1.8	$\mu F$
Operating Temperature	$T_{OP}$	-40	+25	+85	C

**Footnotes:**

1. SENtral's current consumption in normal operation is dependent on a number of variables, including the sensor update rates and the  $I^2C$  sensor bus rate. The range given will be typical for most customers. There is a trade-off between sensor update rates and current consumption, as more frequent sensor update rates result in improved motion-tracking performance, while less frequent sensor update rates result in reduced current consumption. Faster  $I^2C$  sensor bus rates result in lower current consumption.
2. Pass-Through current consumption assumes SENtral previously was in Standby State, which is recommended, and a sensor bus rate of 400 kbits/s (Fast mode).
3. SENtral's  $I^2C$  Host Interface supports Standard, Fast, Fast Plus, and High Speed Modes. High Speed Mode (3400 kHz) is supported with a reduced range of  $V_{DD}$  and bus capacitance. SENtral's  $I^2C$  sensor bus interface supports Standard, Fast, and Fast Plus Modes. Pass-Through State, which connects the sensor bus and host bus, supports Standard and Fast Modes.



## 3 Layout

### 3.1 System Layout

Figure 3-1 provides a basic reference schematic for connecting SENtral with the host system and the various sensors.

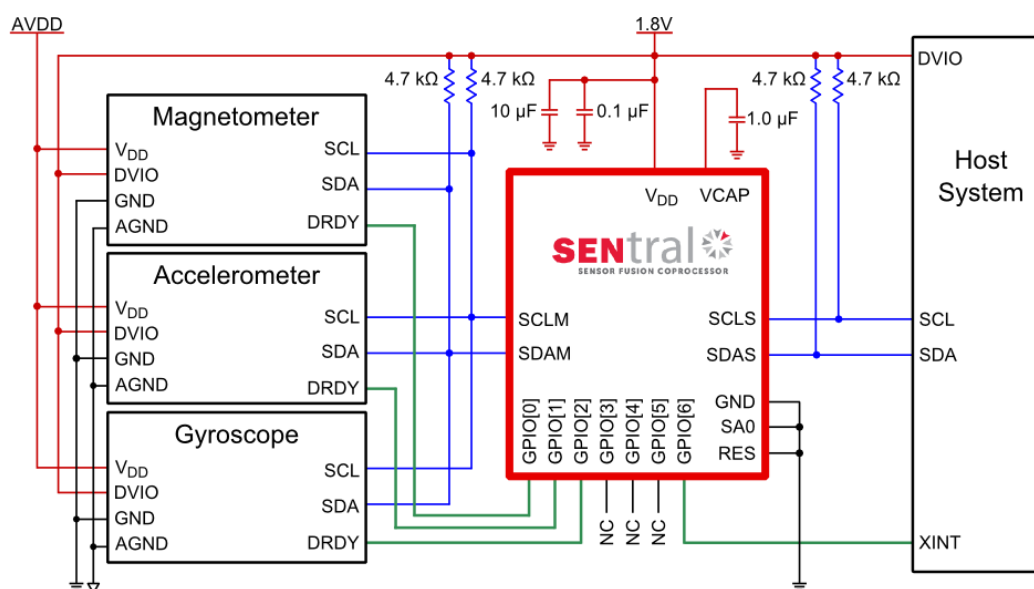

Figure 3-1: SENtral System Reference Schematic

A few points on system layout.

- SENtral communicates with the sensors as the master via a dedicated I<sup>2</sup>C sensor bus. The layout shows a discrete magnetometer, accelerometer, and gyroscope. SENtral also works with combo sensors, such as a single 9-axis sensor or a combo gyro/accel with a discrete magnetometer.
- SENtral acts as a slave on the host system's I<sup>2</sup>C bus. This does not need to be a dedicated bus, although it is shown this way in the schematic. SA0 establishes SENtral's slave address when communicating with the host. It is shown set to ground, but can be set HIGH instead. See Section 4.2.
- The pull-up resistance on the I<sup>2</sup>C lines depends on the number of devices on the bus and the bus speed. Normally 4.7 kΩ is appropriate for Standard or Fast modes (≤400 kbit/sec). See Section 4.4.
- There are three dedicated sensor interrupt lines between the sensors and SENtral, and one interrupt line between the host and SENtral. The default GPIO assignments are shown, but these can be altered with the SENtral Configuration Tool. See Section 6.

## 3.2 Pin Assignments

SENtral's pin-out is a 4x4 ball-grid array, as defined in Figure 7-1. The table below provides the pin assignments.

**Table 3-1: SENtral Pin Assignments**

Pin#	Pin Name	I/O Type*	Description
D1	V <sub>DD</sub>	PWR	Supply voltage
D3	VCAP	PWR	External compensation capacitor for internal core voltage regulator
D2	GND	PWR	Ground
C3	SA0	I	I <sup>2</sup> C slave address bit [0]
B1	SCL <sub>S</sub>	IO	I <sup>2</sup> C host bus SCL clock line
A1	SDA <sub>S</sub>	IO	I <sup>2</sup> C host bus SDA data line
B4	SCL <sub>M</sub>	IO	I <sup>2</sup> C sensor bus SCL clock line
A4	SDA <sub>M</sub>	IO	I <sup>2</sup> C sensor bus SDA data line
D4	GPIO[0]	IO / PUPD	General Purpose IO – Default mag interrupt
C4	GPIO[1]	IO / PUPD	General Purpose IO – Default accel interrupt
A3	GPIO[2]	IO / PUPD	General Purpose IO – Default gyro interrupt
B3	GPIO[3]	IO / PUPD	General Purpose IO – Default not connected
A2	GPIO[4]	IO / PUPD	General Purpose IO – Default not connected
B2	GPIO[5]	IO / PUPD	General Purpose IO – Default not connected
C1	GPIO[6]	IO / PUPD	General Purpose IO – Default host interrupt
C2	RES	-	Not Used – Connect to Ground

**\*I/O Types are:**

- PWR: Power supply Connections
- I: Digital Input
- IO: Digital Input / Output
- PU: Pull-Up
- PD: Pull-Down

---

## 3.3 Sensor Layout

SENtral provides for considerable flexibility in sensor orientation and layout, but there are some basic requirements, as given below.

- All three axes of a sensor must be orthogonal to each other. This is by-design for most accelerometers, gyroscopes, and magnetometers.
- A sensor's X axis and Y axis should act parallel to the primary plane of the motherboard. A sensor's Z axis should act perpendicular to the primary plane.
- Either a sensor's X axis or Y axis should align parallel to the line-of-sight of the motion-tracking device.
- It is NOT necessary that the gyroscope, accelerometer, and magnetometer have their same-axis sensors (i.e. all X-axis sensors) point in the same direction, since sensor orientation is configured when running the SENtral Configuration Tool and stored in the SENtral Configuration File.

Assuming the Orientation Matrix is properly input in the SENtral Configuration Tool, SENtral will output data conforming to a North-East-Down (NED) convention. To convert to East-North-Up (ENU) see Appendix II – Converting Quaternions.

In addition to the requirements listed above, other recommendations regarding sensor layout are given below. These represent good practices, but are not mandatory.

- Accelerometer
  - Locate the accelerometer near the expected center of rotation of the device to minimize rotational accelerations being interpreted as linear accelerations.
- Magnetometer
  - Locate the magnetometer >1 cm away from magnetic sources (hard-iron), such as speaker magnets or known magnetized metals. If uncertain about whether a component is a magnetic source, check it with a Gauss meter if possible.
  - For non-magnetic components, try to avoid placing wireless antenna, power capacitors, inductors, ferrite beads, and components using ferromagnetic materials (Fe, Co, Ni) within 1 cm of the magnetometer. Examples of components in a cell phone which typically contain ferromagnetic materials are the memory card slot, battery, frame, electrical and magnetic noise shields, connectors, and hinges.
  - Materials that are magnetically transparent, and thus relatively safe, include aluminum, gold, titanium, copper, brass, and magnesium. Most stainless steel alloys have relatively weak magnetic properties and are not as safe as those just listed, but don't need as much attention as ferromagnetic materials.
  - Locate high-frequency signal lines away from the magnetometer.
  - Locate power lines away from the magnetometer, per the table below.

**Table 3-2: Recommended Power Line Distance from Magnetometer**

Current (mA)	Recommended Distance (mm)
2	0.2
10	1
50	5
100	10
200	20

### 3.4 Dedicated EEPROM (Optional)

A crucial step in using the SENtral coprocessor is uploading the SENtral Configuration File into SENtral's RAM. This file contains information on how the sensor system is configured in the user's system, and is generated with the SENtral Configuration Tool, as discussed in Section 6. The Configuration File can be manually uploaded from non-volatile memory in the host CPU or automatically uploaded from a dedicated EEPROM. The primary advantages of using a dedicated EEPROM are freeing up host processor memory and minimizing the time from power-up until the upload is complete. The advantages of using host CPU memory are no additional cost and no additional system footprint requirement.

If implementing a dedicated EEPROM, connect it to SENtral as a slave device on the sensor bus, in parallel with the sensors shown in Figure 3-1. The EEPROM upload rate should be set with the SENtral Configuration Tool (see Section 6.1.3). Faster is generally better, although the sensor bus rate is limited to 1 Mb/sec. Writing the Configuration File onto the EEPROM can be accomplished either using an EEPROM programmer or by writing to the EEPROM from the host while SENtral is in Pass-Through State.

The primary EEPROM requirements are:

- ≥320 kilobit (40 kilobit x 8 bits) of memory.
- Shifted address of 0xA0, 0xA2, 0xA4, 0xA6, 0xA8, or 0xAA. (Unshifted address of 0x50, 0x52, 0x54, 0x56, 0x58, or 0x5A.)

The following devices have been used with SENtral, but this list is not exhaustive.

- Microchip 24LC256T-I/SN
- ST M24M01-DRCS
- Renesas R1EX24512ASAS0A

## 4 I<sup>2</sup>C Interface

Communication with the host processor and sensors is via an I<sup>2</sup>C interface and interrupt lines. The SENtral Motion Coprocessor acts as the I<sup>2</sup>C master with the sensors and as a slave with the host processor. The sensor interrupt lines let SENtral know when new data is available, while the host interrupt line lets the host system know when SENtral has updated the quaternions. The sensor and host output data rates are set by the MagRate, AccelRate, GyroRate, and QRateDivisor registers.

SENtral's I<sup>2</sup>C interface complies with NXP's UM10204 specification and user manual, rev 04. Standard, Fast, Fast Plus, and High Speed modes of the I<sup>2</sup>C protocol are supported by SENtral's I<sup>2</sup>C host interface. Below is a link to this document.

[http://www.nxp.com/documents/user\\_manual/UM10204.pdf](http://www.nxp.com/documents/user_manual/UM10204.pdf)

### 4.1 I<sup>2</sup>C Timing

SENtral's I<sup>2</sup>C timing requirements are set forth below, in Figure 4-1 and Table 4-1. For the timing requirements shown in Figure 4-1, transitions are 30% and 70% of V<sub>DD</sub>.

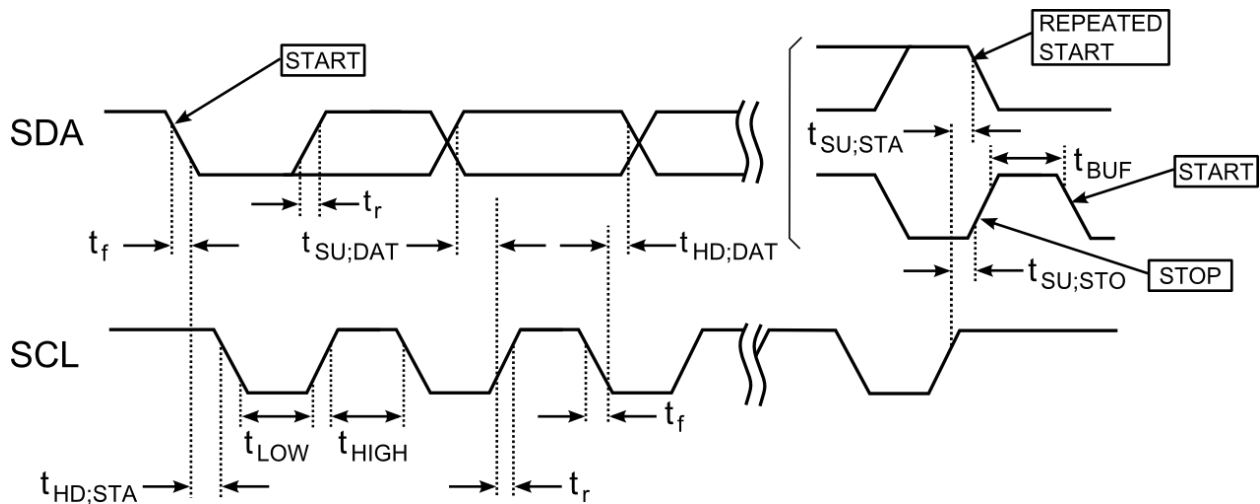

Figure 4-1: I<sup>2</sup>C Timing Diagram

**Table 4-1: I<sup>2</sup>C Timing Parameters**

Symbol	Parameter	Standard		Fast		Fast Plus		Units
		Min	Max	Min	Max	Min	Max	
f <sub>SCL</sub>	SCL Clock	0	100	0	400	0	1000	kHz
t <sub>r</sub>	SDA & SCL Rise Time	-	1000	20	300		120	ns
t <sub>f</sub>	SDA & SCL Fall Time	-	300	20*(V <sub>DD</sub> /5.5V)	300	20*(V <sub>DD</sub> /5.5V)	120	ns
t <sub>LOW</sub>	LOW period of SCL Clock	4.7	-	1.3	-	0.5	-	μs
t <sub>HIGH</sub>	HIGH period of SCL Clock	4.0	-	0.6	-	0.26	-	μs
t <sub>HD;STA</sub>	Hold time (repeated) START	4.0	-	0.6	-	0.26	-	μs
t <sub>HD;DAT</sub>	Data hold time	0	-	0	-	0	-	μs
t <sub>SU;DAT</sub>	Data set-up time	250	-	100	-	50	-	ns
t <sub>SU;STA</sub>	Set-Up time for repeated Start	4.7	-	0.6	-	0.26	-	μs
t <sub>SU;STO</sub>	Stop set-up time	4.0	-	0.6	-	0.26	-	μs
t <sub>BUF</sub>	Bus free time between STOP & START	4.7	-	1.3	-	0.5	-	μs

## 4.2 I<sup>2</sup>C Host Interface (Host Bus)

The host will control SENtral on the host bus via SENtral's I<sup>2</sup>C host interface. The host interface consists of 2 wires: the serial clock, SCLS, and the serial data line, SDAS. Both lines are bi-directional. SENtral is connected to the host bus via the SDAS and SCLS pins, which incorporate open drain drivers within the device. The host bus lines must be externally connected to a positive supply voltage (DVIO) via a pull-up resistor. See Section 4.4 for more on the pull-up resistor.

SENtral's 7-bit I<sup>2</sup>C slave address is 0b010100x, where the most significant 6 bits of the slave address are pre-defined in hardware and are the same for all SENtral devices. The least significant bit is user-configurable, using the SA0 pin to set the bit to '0' or '1'. For example, grounding the SA0 pin ('0' value) results in the 7-bit address of 0b0101000. This should be set so the SENtral slave address is unique to any other devices on the host bus. Note that setting SA0 to '1' requires utilizing microvia technology, as discussed in Section 8.

Data transfer is always initiated by the host. Data is transferred between the host and SENtral serially through the data line (SDAS) in an 8-bit transfer format. The transfer is synchronized by the serial clock line, SCLS. Supported transfer formats are single-byte read, multiple-byte read, single-byte write, and multiple-byte write. The data line can be driven either by the host or SENtral. Normally the serial clock line will be driven by the host, although exceptions can exist when clock-stretching is implemented in Pass-Through State.

#### 4.2.1 I<sup>2</sup>C Slave Transfer formats

Figure 4-2 illustrates writing data to registers in single-byte or multiple-byte mode.

START	SLAVE ADDRESS								RW	ACK	REGISTER ADDRESS (N)								ACK	DATA TO REGISTER (N)								ACK	DATA TO REGISTER (N+1)								ACK	STOP
S	A6	A5	A4	A3	A2	A1	A0	0	0	R7	R6	R5	R4	R3	R2	R1	R0	0	D7	D6	D5	D4	D3	D2	D1	D0	0	D7	D6	D5	D4	D3	D2	D1	D0	0	P	



Figure 4-2: I<sup>2</sup>C Slave Write Example

The I<sup>2</sup>C host interface supports both a read sequence using repeated START conditions, shown in Figure 4-3, and a sequence in which the register address is sent in a separate sequence than the data, shown in Figure 4-4 and Figure 4-5.

START	SLAVE ADDRESS								RW	ACK	REGISTER ADDRESS (N)								ACK	START	SLAVE ADDRESS								RW	ACK	DATA FROM REGISTER (N)								NACK	STOP
S	A6	A5	A4	A3	A2	A1	A0	0	0	R7	R6	R5	R4	R3	R2	R1	R0	0	SR	A6	A5	A4	A3	A2	A1	A0	1	0	D7	D6	D5	D4	D3	D2	D1	D0	1	P		

Data Transferred  
(n bytes + acknowledge)

Figure 4-3: I<sup>2</sup>C Slave Read Example, with Repeated START

START	SLAVE ADDRESS								RW	ACK	REGISTER ADDRESS (N)								ACK	STOP
S	A6	A5	A4	A3	A2	A1	A0	0	0	R7	R6	R5	R4	R3	R2	R1	R0	0	P	

Figure 4-4: I<sup>2</sup>C Slave Write Register Address Only

START	SLAVE ADDRESS								RW	ACK	DATA FROM REG. (N)								ACK	DATA FROM REG. (N+1)								NACK	STOP
S	A6	A5	A4	A3	A2	A1	A0	1	0	D7	D6	D5	D4	D3	D2	D1	D0	0	D7	D6	D5	D4	D3	D2	D1	D0	1	P	

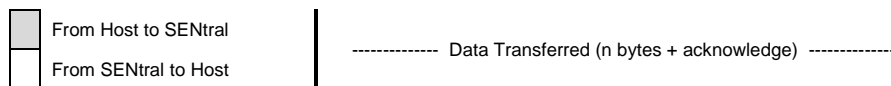

Figure 4-5: I<sup>2</sup>C Slave read register from current address

---

## 4.3 I<sup>2</sup>C Sensor Interface (Sensor Bus)

SENtral communicates with the accelerometer, gyroscope, and magnetometer over the sensor bus, where SENtral acts as the I<sup>2</sup>C master and the sensors act as the I<sup>2</sup>C slaves. On the sensor bus, SENtral initiates data transfer and generates the serial clock. SENtral's I<sup>2</sup>C sensor interface supports Standard mode with a rate up to 100 kbit/s, Fast mode with a rate up to 400 kbit/s, and Fast Plus mode with a rate up to 1000 kbit/s.

The two wires comprising the sensor bus are SDAM, the serial data line, and SCLM, the serial clock. Both are bidirectional and driven by open drain transistors within SENtral. Each line should be attached to a pull-up resistor, which is further discussed in Section 4.4.

---

## 4.4 I<sup>2</sup>C Pull-Up Resistance

The pull-up resistor value for both the host and sensor bus will depend on the I<sup>2</sup>C data rate and the number of devices on the bus. Table 4-2 provides the maximum acceptable bus capacitance, as a function of bus rate, which can be accommodated with a 4.7 k $\Omega$  or 2.4 k $\Omega$  pull-up resistor. As a general rule, each device connected to the bus represents 10 pF of capacitance on the bus, so a bus with 4 devices would require a "Max Cb" value of >40 pF.

**Table 4-2: I<sup>2</sup>C Pull-Up Resistance Table**

I2C Mode	Rate (kbit/s)	Rise Time (ns)	Max Cb (pF)	
			4.7 k $\Omega$ pull-up	2.4 k $\Omega$ pull-up
Standard	100	1000	251.1	491.8
Fast	400	300	75.3	147.5
Fast Plus	1000	120	30.1	59.0
High Speed-1.7 MHz	Clock	1700	80	20.1
	Data	1700	160	40.2
High Speed-3.4 MHz	Clock	3400	40	10.0
	Data	3400	80	20.1

As the table implies, for most Standard and Fast Mode implementations a 4.7 k $\Omega$  pull-up should work well, while a 2.4 k $\Omega$  pull-up normally should be used for Fast Plus. See Section 7.1 of NXP's UM10204 specification for additional information.

[http://www.nxp.com/documents/user\\_manual/UM10204.pdf](http://www.nxp.com/documents/user_manual/UM10204.pdf).



## 5 Operation

Figure 5-1 provides a flow chart of the initialization process, and a detailed discussion of the initialization process follows in Section 5.1. **For the registers, all multi-byte elements are stored and transmitted using the Little Endian convention: the least significant byte is stored at the lowest address and transmitted first over the I<sup>2</sup>C bus.**

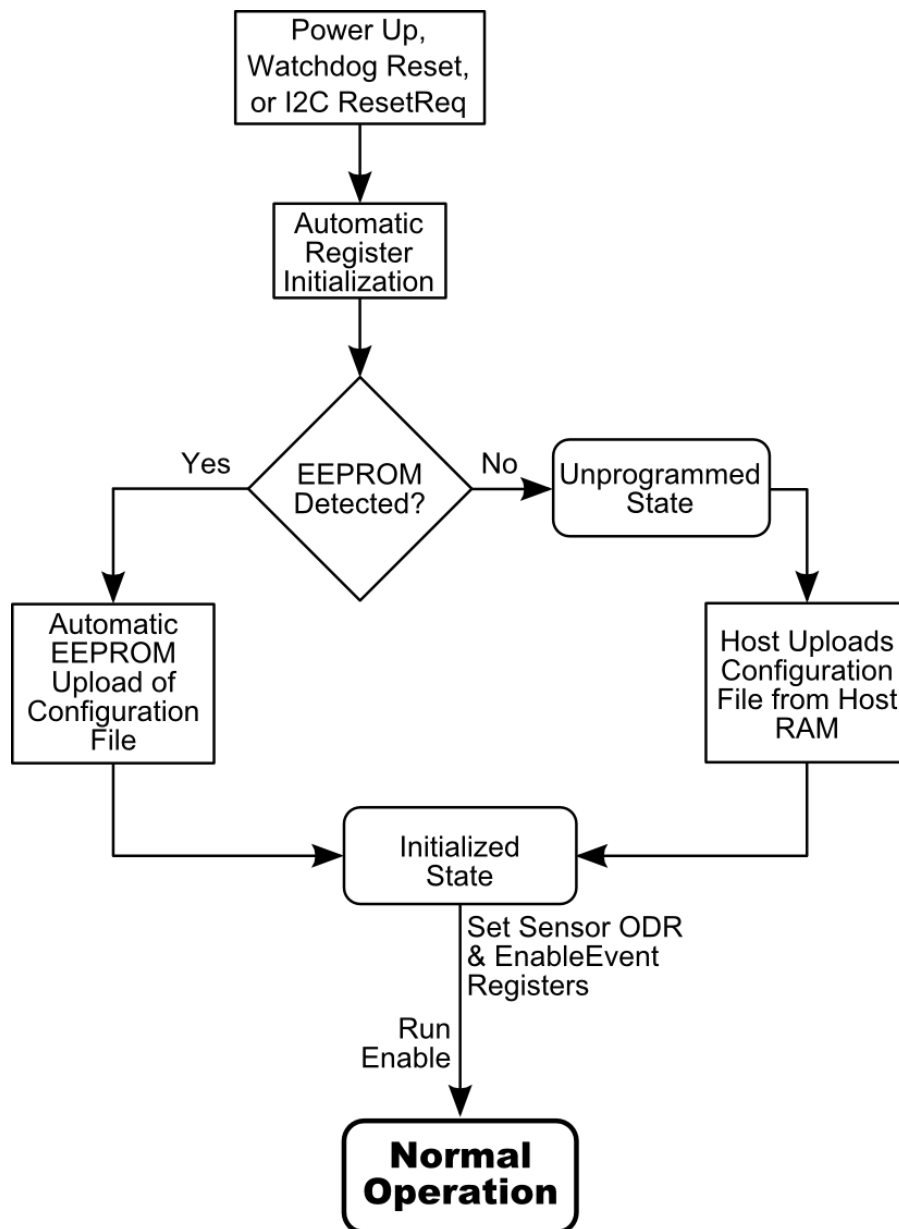

Figure 5-1: SENtral Initialization Sequence

Prior to running SENtral, the Configuration File must be uploaded into SENtral's Configuration RAM. This file contains information regarding how the user's sensor system is configured, such as sensor models, sensor slave addresses, GPIO pin assignments, etc.. The Configuration File is generated with the SENtral Configuration Tool, as discussed in Section 6. It may be stored in the host processor's non-volatile memory or in a dedicated EEPROM connected to SENtral's sensor bus. Once the Configuration File is uploaded, SENtral will move into Initialized state.

Once the initialization sequence is complete, there are three states in which SENtral may reside: Normal Operation, Standby, and Pass-Through. Figure 5-2 indicates the recommended way to get from one state to another, and these states are discussed in detail in Sections 225.3 (Normal Operation), 5.4 (Standby), and 5.5 (Pass-Through).

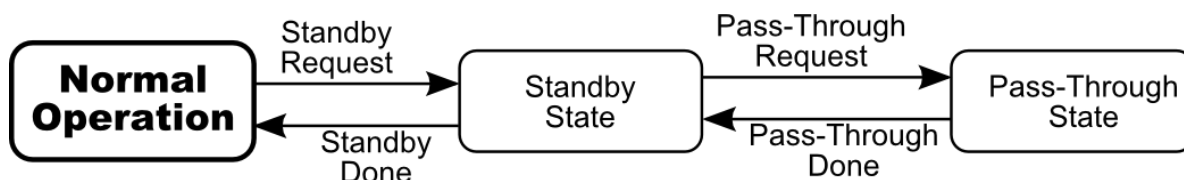

Figure 5-2: SENtral Operational States

---

## 5.1 Power-Up and Configuration File Upload

After powering up or issuing a ResetReq command, SENtral automatically initializes the registers, and then looks for an EEPROM on the sensor bus, as indicated in Figure 5-1.

The Configuration File must now be uploaded. This file contains information on how the sensor system is configured in the user's system, and is generated with the SENtral Configuration Tool, as discussed in Section 6. It can be stored in non-volatile memory in the host CPU or in a dedicated EEPROM. The primary advantages of using a dedicated EEPROM are freeing up host processor memory and minimizing the time from powering up until the upload is complete. The advantages of using the host CPU's memory are no additional cost and no additional system footprint requirement. If a dedicated EEPROM is used, the EEPROM needs to be connected to SENtral as a slave device on the sensor bus.

---

### 5.1.1 Configuration File Upload from EEPROM

If a dedicated EEPROM is used to store the Configuration File, then this EEPROM initially would be loaded with the Configuration File either using an EEPROM programmer or by writing the file into the EEPROM from the host while SENtral is in Pass-Through State. This later method also can be used if a new revision of the SENtral algorithm is available or if the user is testing a variety of sensors and consequently needs

to change the Configuration File depending on the sensors. As previously mentioned, the EEPROM should be connected to SENtral via SENtral’s sensor bus.

**Table 5-1: Configuration File Upload from EEPROM Registers**

Register Name	Address	Register Value
SentralStatus	0x37	[0] EEPROM. 1 = EEPROM detected [1] EEUploadDone. 1 = EEPROM upload completed [2] EEUploadError. 1 = Calculated CRC of EEPROM is incorrect. Only valid when EEUploadDone = 1. [3] Idle. 1 = Device in Unprogrammed or Initialized state. [4] NoEEPROM. 1 = No EEPROM detected.
ResetReq	0x9B	[0] ResetRequest. 1 = Emulate a hard power down/power up.

SENtral automatically checks the sensor bus after powering up or resetting to see if an EEPROM is connected on the sensor bus. If an EEPROM is detected, SENtral checks the first 2 bytes of the EEPROM file, which are fixed for all SENtral Configuration Files, and if these match then it automatically uploads the SENtral Configuration File. Once the upload is complete, SENtral enters Initialized State and waits for instructions from the host. If an EEPROM is not detected, SENtral enters Unprogrammed State.

The host should confirm a successful EEPROM upload by following the steps below:

- Read the value from the SentralStatus register.
- Check bit [0], the EEPROM bit, to ensure an EEPROM is detected by SENtral.
- Check bit [1], the EEUploadDone bit. If this is ‘0’ then the Configuration File upload is not complete, and reread the SentralStatus register until bit [1] = 1.
- Once bit [1] = 1, check bit [2], the EEUpload Error bit. If this is ‘0’, then the upload was successful.

If the Configuration File upload failed, try the following:

- Reinitialize SENtral and retry the process. Send a Reset command by writing 0x01 to the ResetReq register.
- Upload the Configuration File from the host, as discussed in the next section.
- Download the Configuration File from the EEPROM and verify its contents, as given in Appendix I – Configuration File Image Format.
- Reload the Configuration File from the host into the EEPROM.

## 5.1.2 Configuration File Upload from Host

If an EEPROM is not used for storing the Configuration File, then SENtral will enter Unprogrammed State after failing to identify an EEPROM. The host now should upload the Configuration File from host memory. The registers involved are given below:

**Table 5-2: Configuration File Host Upload Registers**

Register Name	Address	Register Value
HostControl	0x34	[0] 1 = RunEnable [1] 1 = HostUpload Enable
UploadAddr	0x94 to 0x95	Initial RAM address (0x0000)
UploadData	0x96	Data to be uploaded
CRCHost	0x97 to 0x9A	CRC32 of the uploaded data since host upload was enabled
ResetReq	0x9B	[0] 1 = Reset SENtral

To upload the Configuration File from the host, perform the following transactions:

- Write value 0x01 to the ResetReq register. This results in a hard reset of SENtral. This is unnecessary if SENtral has just been powered up or Reset.
- Verify the Configuration File image, as given in Appendix I – Configuration File Image Format. Specifically:
  - Ensure the Magic Numbers are correct.
  - Ensure the Uploaded Image Length matches the Uploaded Firmware Image Size.
  - Ensure the Upload Image Length is a multiple of 4 bytes.
- Write 0x02 to the HostControl register. This sets the UploadEnable bit, which enables uploading of the Configuration File.
- Write the initial RAM address, 0x0000, into the UploadAddr register. This normally is an unnecessary operation, since the default after powering up or sending a ResetReq is 0x0000.
- Upload the Configuration File to SENtral’s program RAM. This represents the range from 0x10 to 0x10+UIL-1 in the Configuration File image, as discussed in Appendix I – Configuration File Image Format. Using the UploadData register, data can be burst uploaded in 8-byte or 12-byte groups. Each group of 4 bytes should be sent in byte-reverse order (i.e. little Endian format). Table 5-3 provides an example.

**Table 5-3: Sample Host Upload Data Order**

Byte Order in Config File Image	i	i+1	i+2	i+3	i+4	i+5	i+6	i+7
Config File Image Example	0x01	0x02	0x03	0x04	0x05	0x06	0x07	0x08
Byte Order During Host Upload	i+3	i+2	i+1	i	i+7	i+6	i+5	i+4
Example Byte Sent during Upload	0x04	0x03	0x02	0x01	0x08	0x07	0x06	0x05

- Read the CRCHost register. Compare this to the host-calculated CRC-32 to confirm a successful upload.
- After the reset, write value 0x00 to the HostControl register, which clears the HostUpload bit and places SENtral in Initialized State.

## 5.2 Initial Register Set-Up

After the initialization process is complete, it is necessary to configure a few of SENtral’s registers before running in Normal Operation. These registers are given in Table 5-4.

**Table 5-4: Registers for Initial Set-Up**

Register Name	Address	Register Value
MagRate	0x55	Requested magnetometer output data rate
AccelRate	0x56	Requested accelerometer output data rate divided by 10
GyroRate	0x57	Requested gyroscope output data rate divided by 10
QRateDivisor	0x32	Along with GyroRate, establishes output data rate for quaternion data.
AlgorithmControl	0x54	[0] StandbyEnable. 1 = Enable Standby state [1] RawDataEnable. 1 = Raw data provided in MX, MY, MZ, AX, AY, AZ, GX, GY, & GZ. 0 = Scaled sensor data. [2] HPRoutput. 1 = Heading, pitch, and roll output in QX, QY, & QZ. QW = 0.0. 0 = Quaternion outputs. [3] 6-AxisEnable (rev 1.2 or higher firmware only) 1 = 6-axis sensor fusion 0 = 9-axis sensor fusion [5] ENUoutputEnable. 1 = ENU output 0 = NED output [6] DisableGyroWhenStill. 1 = Gyro off during stillness 0 = Gyro stays on during stillness. [7] Parameter Transfer. 1 = initiate Parameter Transfer 0 = terminate Parameter Transfer

EnableEvents	0x33	'1' indicates an interrupt to the host will be generated for the event. [0] CPUReset. Non-maskable [1] Error [2] QuaternionResult [3] MagResult [4] AccelResult [5] GyroResult [6] Reserved [7] Reserved
--------------	------	--

Perform the following:

- Set the sensor output data rates (ODRs): MagRate, AccelRate, and GyroRate. If a sensor rate is set to 0x00, SENtral will shutdown the sensor and disable SENtral background calibration. There are two major points regarding setting these registers:
  - The AccelRate and GyroRate register values should be 1/10<sup>th</sup> the desired rate, while the MagRate value should match the desired ODR. For example, if the desired ODR is 30 Hz for the magnetometer, 100 Hz for the accelerometer, and 200 Hz for the gyroscope, then the respective register values should be 0x1E (30<sub>d</sub>), 0x0A (10<sub>d</sub>), and 0x14 (20<sub>d</sub>).
  - The actual accelerometer and gyro ODRs are limited to the ODRs supported by the specific sensors. **If the AccelRate or GyroRate register values do not correspond to a supported ODR, then the next highest ODR will be used.** For instance, if the GyroRate register is set to 0x14, which corresponds to 200 Hz, but the gyro supports 95 Hz, 190 Hz, and 380 Hz, then the actual gyro ODR will be 380 Hz since this is the closest supported rate above that requested by the register.
- Establish the quaternion or Euler angle output data rate, where the output data rate equals GyroRate divided by QRateDivisor. The default for QRateDivisor is 0x00, which is interpreted as '1' and results in the output data rate equaling GyroRate.
- Establish how SENtral's orientation and sensor data is to be output. The AlgorithmControl register allows the user to select either quaternion or Euler angles (heading, pitch, and roll) for orientation outputs, and either scaled or raw sensor data outputs. The default is 0x00, corresponding to quaternion and scaled sensor data.
- Establish which events will trigger an interrupt to the host by configuring the EnableEvent register. PNI specifically recommends enabling bit [1], the Error interrupt bit, in addition to whichever other interrupts the user wants.

Example steps to do this are below:

- Write 0x640A0F to the MagRate register. Since SENtral automatically increments to the next register, this also populates the AccelRate and GyroRate registers. This sets MagRate to 100 Hz, AccelRate to 100 Hz, and GyroRate to 150 Hz.

- Write 0x01 to the QRateDivisor Register. This sets the quaternion output data rate to equal the GyroRate. For writing 0x01 this step is optional, since the default also sets the quaternion output data rate equal to GyroRate.
- Write 0x06 to the AlgorithmControl register. This enables heading, pitch, and roll orientation outputs and raw sensor data outputs. This step is optional, as the default register value of 0x00 results in outputs of quaternions and scaled sensor data.
- Write 0x07 to the EnableEvents register. This sets up the host to receive interrupts from SENtral whenever the quaternion results registers are updated, an error has been detected, or when SENtral needs to be reset.

---

**Note:** It is necessary to set the MagRate, AccelRate, AND GyroRate registers to non-zero values for the SENtral algorithm to function properly and to obtain reliable orientation and scaled sensor data. If a [Sensor]Rate register is left as 0x00 after power-up, or is changed to 0x00, this effectively disables that sensor within the SENtral algorithm. Also, the CalStatus, MagTransient, and AlgorithmSlow bits become undefined.

---

## 5.3 Running in Normal Operation

After performing the steps listed above, SENtral is ready to start generating orientation data. Below is a flow diagram for Normal Operation, followed by the pertinent registers, and then the steps to follow when running.

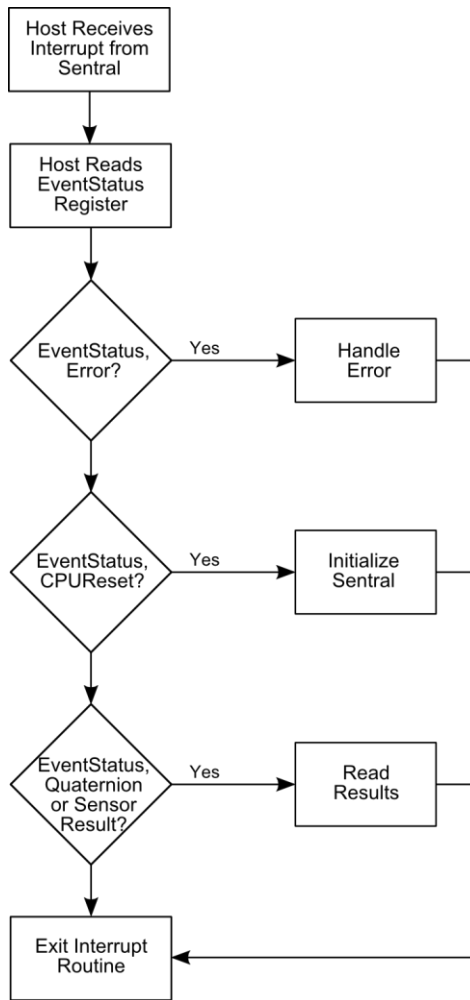

Figure 5-3: SENtral Normal Operation Flow

Table 5-5: Normal Operation Registers

Register Name	Address	Register Value
HostControl	0x34	[0] 1 = RunEnable 0 = Enable Initialized State
EventStatus	0x35	'1' indicates a new event has been generated. [0] CPUReset [1] Error [2] QuaternionResult [3] MagResult [4] AccelResult [5] GyroResult

Below are the steps to follow when operating in Normal Operation state.



- a) Write 0x01 to the HostControl register. This sets the RunEnable bit to ‘1’ and enables the sensors and the SENtral algorithm.
- b) If operating in an interrupt-driven mode, then the host waits until it receives an interrupt signal from SENtral. Alternatively the host may operate on a polling basis, rather than an interrupt-driven basis, in which case the interrupt line may not be used.
- c) Once an interrupt is received by the host or the host otherwise decides to read new data, read the EventStatus register.
- d) Interpret and act on the EventStatus register in the priority shown in Figure 5-3. If bit [1], the Error bit, is ‘1’, see Section 5.3.1. If bit [0], the CPUReset bit, is ‘1’, see Section 5.3.2. If bits [2], [3], [4], or [5], the Results bits, are ‘1’, see Section 5.3.1.
- e) Repeat steps c and d until new orientation data is not needed and/or the host decides to enter a different state.

**Note that reading the EventStatus register clears it.** It is possible for more than one bit position to be ‘1’ in the EventStatus register, especially if the host does not always read the EventStatus register after receiving an interrupt. Similarly, if multiple bits are set to ‘1’ in the EventStatus register, once the register is read all the bits will be set to ‘0’. For this reason the EventStatus register should be processed in the priority shown in Figure 5-3, as information will be cleared for events that are not handled.

---

### 5.3.1 Error

In the event of an error, SENtral will trigger an error interrupt and SENtral will enter Standby State. See the Section 5.6 for recommendations on Troubleshooting and/or reset SENtral by sending 0x01 to the ResetReq register, at address 0x9B.

---

### 5.3.2 CPUReset

SENtral will report a CPUReset event after the ResetReq command has been issued, and prior to uploading the Configuration File. In this case, SENtral is in Unprogrammed State and needs the Configuration File to be uploaded. If a dedicated EEPROM is used to store the Configuration File, then CPUReset should not be encountered as the Configuration File is automatically uploaded.

---

### 5.3.3 Read Results

The Results Registers’ addresses, formats, and full-scale ranges are given below in Table 5-6. For an explanation of how to convert quaternions to the rotation vector, the rotation matrix, or heading, pitch, and roll (Euler angles), see Appendix II – Converting Quaternions. The resolution is 32 kHz for all timestamps.

**Note:** All multi-byte elements are stored and transmitted using the Little Endian convention: the least significant byte is stored at the lowest address and transmitted first over the I<sup>2</sup>C bus.

**Table 5-6: Results Registers**

Name	Address (Hex)	Description	Format	Full-Scale Range
QX	00 – 03	Normalized Quaternion – X, or Heading	Float32	0.0 – 1.0, or $\pm\pi$
QY	04 – 07	Normalized Quaternion – Y, or Pitch	Float32	0.0 – 1.0, or $\pm\pi/2$
QZ	08 – 0B	Normalized Quaternion – Z, or Roll	Float32	0.0 – 1.0, or $\pm\pi$
QW	0C – 0F	Normalized Quaternion – W, or 0.0	Float32	0.0 – 1.0
QTime	10 – 11	Quaternion Data Timestamp	UInt16	0 – 2048 msec
MX	12 – 13	Magnetic Field – X Axis, or Raw Mag Data	Int16	$\pm 1000 \mu\text{T}$ when scaled
MY	14 – 15	Magnetic Field – Y Axis, or Raw Mag Data	Int16	$\pm 1000 \mu\text{T}$ when scaled
MZ	16 – 17	Magnetic Field – Z Axis, or Raw Mag Data	Int16	$\pm 1000 \mu\text{T}$ when scaled
MTime	18 – 19	Magnetometer Interrupt Timestamp	UInt16	0 – 2048 msec
AX	1A – 1B	Linear Acceleration – X Axis, or Raw Accel Data	Int16	$\pm 16 \text{ g}$ when scaled
AY	1C – 1D	Linear Acceleration – Y Axis, or Raw Accel Data	Int16	$\pm 16 \text{ g}$ when scaled
AZ	1E – 1F	Linear Acceleration – Z Axis, or Raw Accel Data	Int16	$\pm 16 \text{ g}$ when scaled
ATime	20 – 21	Accelerometer Interrupt Timestamp	UInt16	0 – 2048 msec
GX	22 – 23	Rotational Velocity – X Axis, or Raw Gyro Data	Int16	$\pm 5000^\circ/\text{s}$ when scaled
GY	24 – 25	Rotational Velocity – Y Axis, or Raw Gyro Data	Int16	$\pm 5000^\circ/\text{s}$ when scaled
GZ	26 – 27	Rotational Velocity – Z Axis, or Raw Gyro Data	Int16	$\pm 5000^\circ/\text{s}$ when scaled
GTime	28 – 29	Gyroscope Interrupt Timestamp	UInt16	0.0 – 2.048 sec

## 5.4 Standby State

In Standby State overall system power consumption is dramatically reduced because both the SENtral algorithm and the sensors are shut down. Table 5-7 provides the registers associated with Standby State.

**Table 5-7: Standby Registers**

Register Name	Address	Register Value
AlgorithmControl	0x54	[0] 1 = StandbyEnable 0 = Disable Standby State
AlgorithmStatus	0x38	[0] 1 = SENtral in Standby State 0 = SENtral not in Standby State

The steps to enter and exit Standby State are given below:

- Write 0x01 to the AlgorithmControl register. This places SENtral in Standby State.
- Read the AlgorithmStatus register. If bit [0] is '1', then SENtral is in Standby State. This step is optional.
- When you are ready to exit Standby State, write 0x00 to the AlgorithmControl register. This takes SENtral out of Standby State and normally will place it back into Normal Operation.
- Read the AlgorithmStatus register. If bit [0] is '0', then SENtral is not in Standby State. This step is optional.

---

## 5.5 Pass-Through State

SENtral can be configured so the host communicates directly with devices on the sensor bus by placing SENtral into Pass-Through State. In Pass-Through State, SENtral's sensor and host interfaces are connected by internal switches so the host system communicates directly with the sensors and/or dedicated EEPROM. To enter Pass-Through State, SENtral first should be in either Standby, Initialized, or Unprogrammed State. Consequently, in Pass-Through State the SENtral algorithm, host interrupt line, and sensors are disabled, unless a sensor is directly turned on by the host. When exiting Pass-Through State, SENtral will return to its prior state.

---

**Note:** *When entering Pass-Through State the sensor's registers retain the values established by SENtral, and when exiting Pass-Through State any register changes will be retained.*

---

Uses for the Pass-Through State include:

- Direct control of sensors, if desired.
- Debugging.
- Communication with the dedicated EEPROM, if implemented. Specifically, if a new Configuration File is generated, the host can write this into the EEPROM when in Pass-Through State.

Since operating in Pass-Through State requires stopping the SENtral algorithm, Pass-Through State is not recommended for accessing sensor data unless reliable heading data is not required. If sensor data and reliable heading data are both desired, scaled sensor data can be accessed during Normal Operation from the Results Registers, as given in Table 5-6.

Table 5-8 provides the registers associated with Pass-Through State.

**Table 5-8: Pass-Through Registers**

Register Name	Address	Register Value
AlgorithmControl	0x54	[0] 1 = StandbyEnable 0 = Disable Standby State
AlgorithmStatus	0x38	[0] 1 = SENtral in Standby State 0 = SENtral not in Standby State
PassThroughControl	0xA0	[0] 1 = Enable Pass-Through State 0 = Disable Pass-Through State
PassThroughStatus	0x9E	[0] 1 = SENtral in Pass-Through State. 0 = SENtral not in Pass-Through State.

The steps to go in and out of Pass-Through State are given below.

- Write 0x01 to the AlgorithmControl register. This places SENtral in Standby State.
- Write 0x01 to the PassThroughControl register. This places SENtral in Pass-Through State.
- Read the PassThroughStatus register. If bit [0] is '1', then SENtral is in Pass-Through State. This step is optional.
- When you are done in Pass-Through State, write 0x00 to the PassThroughControl register. This terminates Pass-Through mode and returns SENtral to Standby State.
- Write 0x00 to the AlgorithmControl register. This takes SENtral out of Standby State and normally will place it back into Normal Operation.

## 5.6 Troubleshooting

This section provides guidance in troubleshooting SENtral, and is divided into hardware-related and software-related errors.

### 5.6.1 Hardware-Related Error Conditions

Possible indications of a hardware-related problem are given below in Table 5-9.

**Table 5-9: Hardware-Related Error Indications**

Register Name	Address	Error Indication
EventStatus	0x35	[0] 1 = CPUReset. SENtral Configuration File needs uploading. See Section 5.1.
SentralStatus	0x37	[2] 1 = EEUploadError. Issue with uploading from the dedicated EEPROM. See Section 5.1.
MagRate	0x55	0x00 – Value lost
AccelRate	0x56	0x00 – Value lost
GyroRate	0x57	0x00 – Value lost

In the event of such errors, SENtral will enter Standby State, shut down the sensors, and generate an interrupt to the host. Possible reasons for hardware-related errors include problems with an external EEPROM upload, power transients detected by power management, and errors in software detected by Watchdog. Often the error can be cleared by sending the ResetReq command and reloading the Configuration File.

### 5.6.2 Software-Related Error Conditions

Possible indications of software-related errors are given below in Table 5-10:

**Table 5-10: Software-Related Error Indications**

Register Name	Address	Error Indication
EventStatus	0x35	[1] 1 = Error.
SensorStatus	0x36	Non-zero value indicates sensor-related error. Check sensors by communicating in Pass-Through State. See Table 5-11
SentralStatus	0x37	[3] 1 = Idle. SENtral in Initialized or Unprogrammed State.
ErrorRegister	0x50	Non-zero value indicated an error. See Table 5-12.
RAMVersion	0x72, 0x73	Unexpected Configuration File revision level.

If the SensorStatus register indicates a non-zero value, then the value provides additional information on the sensor that is causing a problem, as given in Table 5-11.

**Table 5-11: SensorStatus Register Values**

Register Name	Address	Error Indication
SensorStatus	0x36	[0] MagNACK. 1 = NACK from magnetometer [1] AccelNACK. 1 = NACK from accelerometer [2] GyroNACK. 1 = NACK from gyroscope [4] MagDeviceIDErr. 1 = Unexpected DeviceID from magnetometer [5] AccelDeviceIDErr. 1 = Unexpected DeviceID from accelerometer [6] GyroDeviceIDErr. 1 = Unexpected DeviceID from gyroscope.

If the ErrorRegister indicates a non-zero value, then the value provides additional information on the sensor that is causing a problem, as given in Table 5-12.

**Table 5-12: ErrorRegister Values**

Value	Error Condition	Response
0x00	No error	
0x80	Invalid sample rate selected	Check sensor rate settings.
0x30	Mathematical Error	Check for software updates
0x21	Magnetometer initialization failed	This error can be caused by a wrong driver, physically bad sensor connection, or incorrect I <sup>2</sup> C device address in the driver
0x22	Accelerometer initialization failed	
0x24	Gyroscope initialization failed	
0x11	Magnetometer rate failure	This error indicates the given sensor is unreliable and has stopped producing data.
0x12	Accelerometer rate failure	
0x14	Gyroscope rate failure	

If the RAMVersion register values do not correspond to the expected Configuration File revision level, as given in Table 5-13, certain features or functions that are expected to be available may not be available, or they may not function as expected. This normally can be remedied by generating the latest Configuration File revision level using the SENtral

Configuration Tool, as discussed in Section 6, and then loading this into an optional dedicated EEPROM or otherwise uploading it into SENtral.

**Table 5-13: RAMVersion Register Values**

0x72 Register Value	0x73 Register Value	RAM Version (Hex / Decimal)	Config File Revision
0x04	0x0C	0x0C04 / 3076	1.0
0xD5	0x0C	0x0CD5 / 3285	1.1
0xED	0x0E	0x0EED / 3821	1.2
0x7B	0x0F	0x0F7B / 3963	1.3

## 6 SENtral Configuration Tool

Before using the SENtral Motion Coprocessor, the SENtral Configuration File must be generated using the SENtral Configuration Tool. As discussed in prior sections, the Configuration File contains information on how the sensor system is configured in the user's system.

To access the SENtral Configuration Tool, go to: <http://www.sentraltoolkit.com>. The tool is for SENtral customers, and registration is required. Registration requests are reviewed at PNI. Typically it takes less than one business day to activate a registration request.

The SENtral Configuration Tool provides an intuitive GUI which allows the user to easily generate the Configuration File. A screen shot of the tool is given in Figure 6-1, and a discussion of the settings follows. Once the various fields are correctly populated, click <Generate> to create the SENtral Configuration File. A zip file will automatically download onto your computer containing the Configuration File, “sentrall\_[rev]\_[mag]\_[accel]\_[gyro].fw”, and a .cfg file providing the data input into the Configuration Tool. The .cfg file can be opened with a text editor. Additionally, the .cfg file can be uploaded into the Configuration Tool by clicking <Load Config> and then selecting the desired .cfg file. The “GS and M&M Configuration” link opens a pop-up window with the configurations for the various SENtral M&M and GS modules.

The screenshot shows the SENtral Configuration Tool web interface. The browser address bar shows [www.sentraltoolkit.com](http://www.sentraltoolkit.com). The page features the SENtral logo and the text "SENSOR FUSION COPROCESSOR". The main content area is divided into four configuration sections:

- General Settings:** SDK Revision (Select...), Host Interrupt Pin (GPIO[6]), EEPROM Max. Upload Speed (100 kHz).
- Magnetometer Configuration:** Sensor (Select...), Interrupt Pin (GPIO[0]), 7-bit Slave Address (Select...), Orientation Matrix (1 0 0, 0 1 0, 0 0 1), Cal Offsets (0 0 0).
- Accelerometer Configuration:** Sensor (Select...), Interrupt Pin (GPIO[1]), 7-bit Slave Address (Select...), Orientation Matrix (1 0 0, 0 1 0, 0 0 1), Cal Offsets (0 0 0).
- Gyroscope Configuration:** Sensor (Select...), Interrupt Pin (GPIO[2]), 7-bit Slave Address (Select...), Orientation Matrix (1 0 0, 0 1 0, 0 0 1), Cal Offsets (0 0 0).

At the bottom of the form, there are buttons for "Generate" and "Load Config", and a link for "GS and M&M Configurations".

Figure 6-1: SENtral Configuration Tool



---

## 6.1 Configuration Tool General Settings

---

### 6.1.1 SDK Revision

This establishes the revision of the firmware to be generated. Normally the latest revision is most desirable, but prior revisions are retained for customers that have qualified an older revision level.

### 6.1.2 Host Interrupt Pin

This establishes which GPIO pin is used to send an event interrupt to the host system. The default is GPIO[6], but any of the GPIO pins can be used for this function.

### 6.1.3 EEPROM Max. Upload Speed

If the user incorporates a dedicated EEPROM to store the SENtral's Configuration File, then this field establishes the maximum data rate the configuration EEPROM can accommodate. If there is no EEPROM, this setting has no meaning. SENtral automatically determines if a dedicated EEPROM is present.

---

## 6.2 Configuration Tool Sensor Configuration

---

The sensors attached to SENtral must be configured correctly for SENtral to properly function. The magnetometer, accelerometer, and gyroscope are configured in a similar manner, so the parameters discussed below apply to all three sensors.

### 6.2.1 Sensor

The drop-down menus are used to select the sensor models incorporated into the user's system. If a sensor is not listed, then a driver has not been developed for that sensor.

### 6.2.2 Interrupt Pin

This drop-down menu establishes which General Purpose IO pin is used to send a sensor interrupt signal to SENtral. As shown in the reference schematic, Figure 3-1, the default is to use GPIO[0] for the magnetometer, GPIO[1] for the accelerometer, and GPIO[2] for the gyroscope. However, the GPIO pins are interchangeable and can be configured as is most convenient for the user.

### 6.2.3 Slave Address

This establishes the slave address for the respective sensor, and the user needs to input the sensor's slave address here. The 7-bit slave address will be provided in the sensor's

technical data sheet and normally will be a function of 5 or 6 fixed bits and 1 or 2 bits that are configurable by 1 or 2 of the sensor's pins.

---

#### 6.2.4 Orientation Matrix

This matrix defines how the sensors are physically laid out in the host system. The values are normally 1s, -1s, or 0s. The matrix is used to convert the physical layout into a north-east-down (NED) convention, where “north” is defined as the line-of-sight or direction of travel. The matrix is defined as shown in the equation below:

$$\begin{pmatrix} N \\ E \\ D \end{pmatrix} = \begin{pmatrix} A & B & C \\ D & E & F \\ G & H & I \end{pmatrix} \begin{pmatrix} X \\ Y \\ Z \end{pmatrix}$$

where A through I are the matrix values that need to be populated (1s or 0s), X, Y, and Z represent the orientation of the x-axis, y-axis, and z-axis sensors, where north is defined as the line of sight, and NED is the north-east-down convention that the orientation matrix converts [X, Y, Z] into.

**For the accelerometer matrix, it is necessary to multiply the matrix by -1.**

#### Examples:

Below are three examples. The first is if the sensor is laid out in an NED convention, such that the x-axis points north, the y-axis points east, and the z-axis points down. Recall that “north” is defined as the line-of-sight or direction of travel. In this case the orientation matrix is the identity matrix, as given below.

$$\begin{pmatrix} N \\ E \\ D \end{pmatrix} = \begin{pmatrix} 1 & 0 & 0 \\ 0 & 1 & 0 \\ 0 & 0 & 1 \end{pmatrix} \begin{pmatrix} N \\ E \\ D \end{pmatrix}$$

Another common convention is east-north-up (ENU), where the x-axis points east, the y-axis points north, and the z-axis points up, in which case the orientation matrix and associated matrix math are given below.

$$\begin{pmatrix} N \\ E \\ D \end{pmatrix} = \begin{pmatrix} 0 & 1 & 0 \\ 1 & 0 & 0 \\ 0 & 0 & -1 \end{pmatrix} \begin{pmatrix} E \\ N \\ U \end{pmatrix}$$

The final example is west-south-down (WSD). This matrix would be appropriate for an ENU accelerometer, since it incorporates the -1 multiplication factor. The orientation matrix and associated matrix math are given below.

$$\begin{pmatrix} N \\ E \\ D \end{pmatrix} = \begin{pmatrix} 0 & -1 & 0 \\ -1 & 0 & 0 \\ 0 & 0 & 1 \end{pmatrix} \begin{pmatrix} W \\ S \\ D \end{pmatrix}$$

---

### 6.2.5 Cal Offsets

Normally these fields will be '0'. However if the user has information indicating a given model of sensor consistently has a fixed measurement offset, then these fields allow the user to tailor the SENtral algorithm. For example, assume statistical data from a manufacturer regarding their accelerometer indicates their z-axis sensor has an average reading of 1.1 g when actually experiencing 1.0 g of gravitational force. In this case, the user can enter an offset on the z-axis of 0.1g for the accelerometer. The fields are given in X, Y, Z order, and the units are as follows:

- Magnetometer: 1.0 = +50  $\mu$ T
- Accelerometer: 1.0 = +1 g
- Gyroscope: 1.0 = +1 radian/second

## 7 Package Information

Dimensions in mm

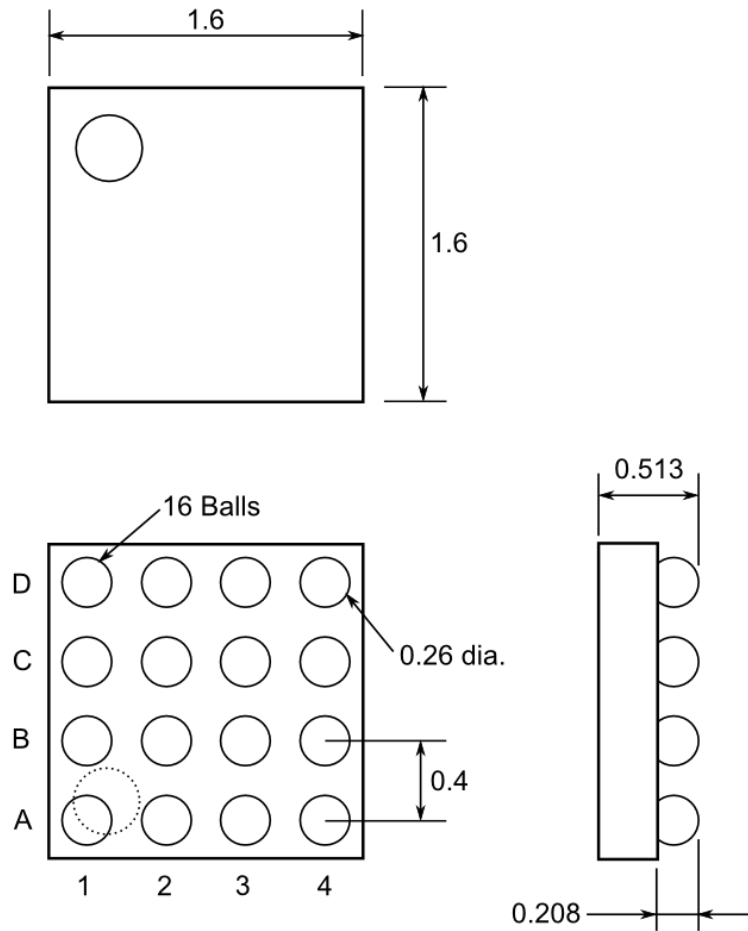

**Note:** For Pin-Out, see

Table 3-1

Figure 7-1: Mechanical Drawing

**Dimensions in mm**

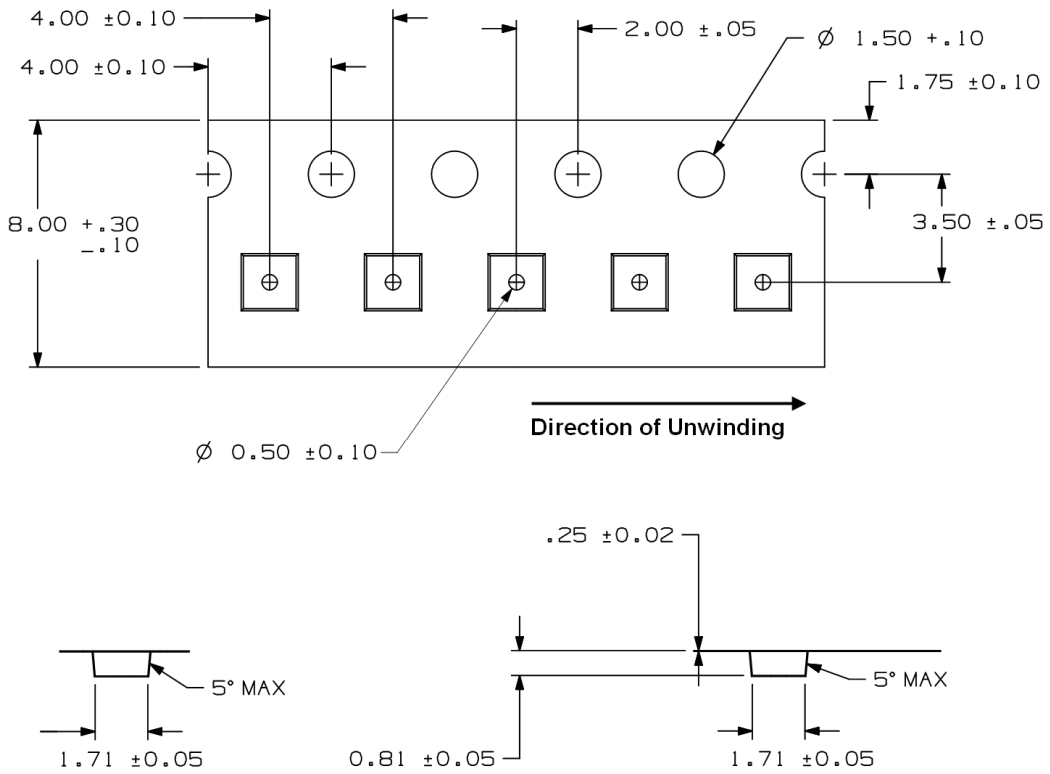

*Figure 7-2: Tape Dimensions*

---

## 8 Assembly Guidelines

SENtral is provided in a lead-free wafer-level chip-scale package (WL-CSP). General design guidelines can be found in Amkor's "Application Note for Surface Mount Assembly of Amkor's Eutectic and Lead-Free CSP<sup>nl</sup>™ Wafer Level Chip Scale Packages", which is available from Amkor's website. Specific assembly guidelines are discussed below.

Comments specific to SENtral include:

- Microvia technology is NOT required if GPIO[3] and GPIO[5] are not used and the slave address pin, SA0, is set LOW. In this case the slave address pin, C3, should be connected to C2 (unused), and C2 should be connected to D2, which is GND. Pins B2, GPIO[5], and B3, GPIO[3], should be left unconnected.
- If either GPIO[3] and GPIO[5] are to be used or the slave address pin, SA0, is to be set HI, then microvia technology is required. Due to SENtral's ball-grid-array 0.4 mm pitch and 0.26 mm ball diameter, connections to these inner pins should be made with a via-in-pad design using microvias.

General CSP assembly guidelines for SENtral include:

- A non-solder mask defined (NSMD) land pattern is recommended.
- Solder mask registration is critical and the correct solder mask opening dimension should be 50um either side of the copper pad.
- The actual size of the copper pad should be between 80% and 100% of the diameter of the solder ball.
- The copper layer thickness should 30 um or less.
- The copper pads should be finished with Organic Solderability Preservative (OSP) coating, such as ENTEK-PLUS Cu 106A.
- Standard epoxy glass PCB substrates are compatible. High temperature FR4 is preferred over standard FR4 for improved package reliability.

Figure 8-1 provides design parameters for a typical SENtral solder mask and pad pattern.

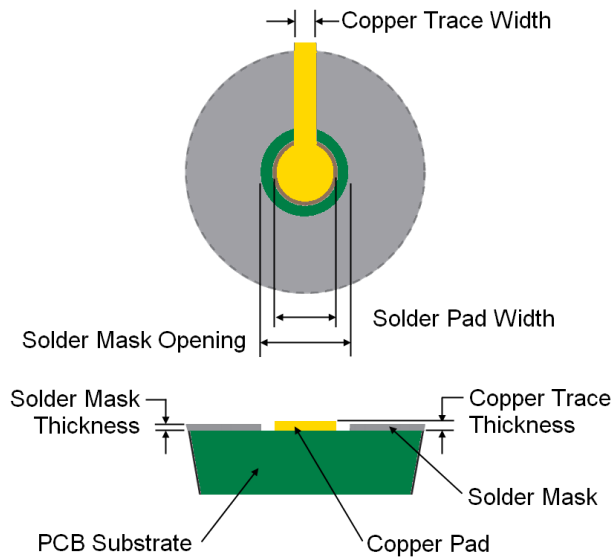

<b>Pitch</b>	<b>0.4 mm</b>
<b>Nominal Sphere Diameter (μm)</b>	250
<b>UBM Diameter (μm)</b>	205
<b>Bump Height (μm)</b>	210
<b>Bump Diameter (μm)</b>	260

**PCB Design Parameters**

<b>Solder Pad Width (μm)</b>	225
<b>Solder Mask Opening (μm)</b>	325
<b>Solder Mask Thickness (μm)</b>	25
<b>Copper Trace Thickness(μm)</b>	30
<b>Copper Trace Width (μm)</b>	100

*Figure 8-1: Typical Solder Mask and Land Pad Parameters*

A typical recommended solder reflow profile is given in Figure 8-2 and the associated processing parameters are given in Table 8-1, both on the following page. Oven type and tolerances, thermocouple tolerance, solder type, and the temperature difference across the board will affect the actual implemented profile.

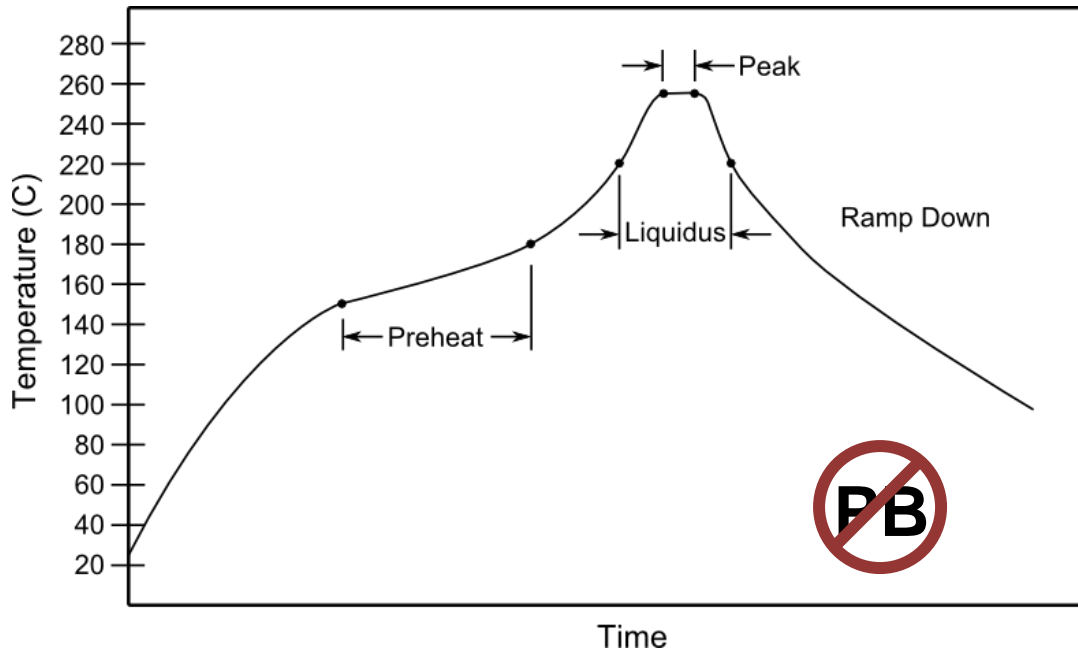

Figure 8-2: Typical Solder Reflow Profile

Table 8-1: Typical Solder Processing Parameters

Parameter	Value
Ramp Up Rate	3°C/second
Preheat Temperature Range	150°C to 180°C
Preheat Time	60 – 180 seconds
Liquidus Temperature	220°C
Time above Liquidus	30 – 90 seconds
Peak Temperature	255°C ±5°C
Time within 5°C of Peak Temperature	10 – 20 seconds
Ramp Down Rate	6°C/second maximum



## Appendix I – Configuration File Image Format

Table A1-1 provides the format for the Configuration File image. While understanding the Configuration File image format is not mandatory for operation, it can be useful when debugging errors.

**Table A1-1: Configuration File Image Format**

Byte Index	Content	Note
0x00	Magic Number Lower Byte	0x2A is expected value
0x01	Magic Number Upper Byte	0x65 is expected value
0x02 & 0x03	Flags	Bit [0] – EEPROMExec 0 = Execute after EEPROM upload (default) 1 = Do not execute after EEPROM upload  Bits [8] to [10] – I2CClockSpeed 000 – 1 Mbit/s 001 – 833 kbit/s 010 – 400 kbit/s 011 – 333 kbit/s 100 – 100 kbit/s Others – 83 kbit/s  Bits [11] to [14] – ROMVerExp. 0001 – version 0x7A8 0010 – version 0x9E6
0x04 to 0x07	CRC32 of uploaded image	Stored in Little Endian Format
0x08 to 0x0B	Reserved	0x00000000
0x0C & 0x0D	Uploaded Image Length (UIL)	Stored in Little Endian Format
0x0E & 0x0F	Reserved	0x0000
0x10 to 0x10+UIL-46	Uploaded Image – Instructions & Configuration File Data	CRC32 is calculated over uploaded image
0x10+UIL-45 to 0x10+UIL-1	Uploaded Image –Config. File Data Structure. See Table A1-2.	

**Table A1-2: Configuration File Data Structure**

Byte Index	Content	Note
0x00	Signature Lower Byte	Value is 0x8B. Can be used to locate the data structure within the image.
0x01	Signature Upper Byte	Value is 0xC8. Can be used to locate the data structure within the image.
0x02 to 0x07	Reserved	
0x08 & 0x09	RAM Version	Firmware version number
0x0A	Version	Configuration Structure Version
0x0B	Boot Protocol	Used for standalone applications
0x0C to 0x13	PinSelection	Bit 0-3 Host IRQ pin selection Others – reserved
0x14 to 0x1B	PullSelection	Bit 0 & 1 GPIO0 pull selection 0=no pulls, 1=pull-down, 2=pull-up, 3=keep defaults Bit 2 & 3 GPIO1 pull selection Bit 4 & 5 GPIO2 pull selection Bit 6 & 7 GPIO3 pull selection Bit 8 & 9 GPIO4 pull selection Bit 10 & 11 GPIO5 pull selection Bit 12 & 13 GPIO6 pull selection Others – reserved
0x1C to 0x2B	Device Name	16 character string

When uploading the Configuration File from a dedicated EEPROM, SENtral first checks the Magic Number upper and lower bytes to ensure they match the expected values. If they do, then the upload will commence, and during the upload SENtral calculates the CRC32 value over the incoming data. At the end of the upload process, the calculated CRC32 value is compared with the valued stored in the header. If they match the Configuration File has been successfully uploaded. If the the EEPROMExec bit is set to '0', then the SENtral algorithm automatically will execute and move SENtral in Initialized state, as shown in Figure 5-1.

## Appendix II – Converting Quaternions

SENtral outputs orientation data in quaternions, using a North-East-Down (NED) convention. This is done to avoid the singularities inherent in using Euler angles (heading, pitch, and roll), and because the fusion algorithms are easier to implement with quaternions. However, normally quaternions are not the desired final output format. Most end users will want heading, pitch, and roll, while Android looks for a rotation vector and generally uses a rotation matrix for orientation. Plus, Android and Win8 both expect data to be presented in the East-North-Up (ENU) convention. This appendix discusses how to convert SENtral’s output quaternions into these other output formats.

### Converting from NED to ENU

While the North-East-Down (NED) convention is common in many industries, both Android and Windows 8 use the East-North-Up convention. Below is the equation to convert from NED to ENU.

$$Q_{\text{ENU}} = \begin{pmatrix} \begin{matrix} 0 & 0 & -0.707 & 0.707 \\ 0 & 0 & 0.707 & 0.707 \\ 0.707 & -0.707 & 0 & 0 \\ -0.707 & -0.707 & 0 & 0 \end{matrix} \\ \begin{matrix} \begin{matrix} Q_w & -Q_z & Q_y & -Q_x \\ Q_z & Q_w & -Q_x & -Q_y \\ -Q_y & Q_x & Q_w & -Q_z \\ Q_x & Q_y & Q_z & Q_w \end{matrix} \\ \text{NED} \end{matrix} \end{pmatrix}$$

### Heading, Pitch, and Roll

Most end users will want orientation data reported as heading, pitch, and roll. Below are the Excel transformation equations. Note that for other programs, such as Matlab, the ATAN2 arguments may be reversed.

- Heading = atan2[(Qx<sup>2</sup> – Qy<sup>2</sup> – Qz<sup>2</sup> + Qw<sup>2</sup>), 2\*(QxQy + QzQw)]
- Pitch = asin[-2\*(QxQz – QyQw)]
- Roll = atan2[(-Qx<sup>2</sup> – Qy<sup>2</sup> + Qz<sup>2</sup> + Qw<sup>2</sup>), 2\*(QxQw + QyQz)]

Where:

- Results are in radians.
- The quaternions are the outputs from SENtral in NED convention.
- Heading increases as the device rotates clockwise around a positive Z axis, and the range is 0° – 360°. (i.e. it matches what you would expect on a compass.)
- Pitch increases when pitching upward and the range is ±90°.
- Roll increases when rolling clockwise and the range is ±180°.

## Rotation Vector

The rotation vector is the first three elements of the quaternion output,  $Q_x$ ,  $Q_y$ , and  $Q_z$ . The fourth element,  $Q_w$ , is not included in the rotation vector. The rotation vector in ENU convention will be the first three elements of  $Q_{ENU}$ , discussed above.

## Rotation Matrix, or Direction Cosine Matrix (DCM)

The rotation matrix, also known as the direction cosine matrix (DCM), can be established from the quaternion output using the following conversion.  $Q_{ENU}$  values can be substituted to give the rotation matrix with an ENU convention.

$$R = \begin{array}{|c|c|c|} \hline Q_w^2 + Q_x^2 - Q_y^2 - Q_z^2 & 2*(Q_x*Q_y + Q_w*Q_z) & 2*(Q_x*Q_z - Q_w*Q_y) \\ \hline 2*(Q_x*Q_y - Q_w*Q_z) & Q_w^2 - Q_x^2 + Q_y^2 - Q_z^2 & 2*(Q_y*Q_z + Q_w*Q_x) \\ \hline 2*(Q_x*Q_z + Q_w*Q_y) & 2*(Q_y*Q_z - Q_w*Q_x) & Q_w^2 - Q_x^2 - Q_y^2 + Q_z^2 \\ \hline \end{array}$$

## Appendix III – Parameter Transfer

**Note:** Implementing the parameter transfer process is not necessary when using SENtral, but can be useful for enabling a warm start, for setting the sensor ranges to non-default values, and/or for reading the device driver IDs.

This appendix provides the protocol for implementing SENtral’s parameter transfer process. A parameter transfer involves the host either loading parameter values into SENtral, or retrieving parameter values currently used by SENtral.

### Register Usage

Table A3-1 provides the registers used for the parameter transfer process.

**Table A3-1: Registers Used for Parameter Transfer**

Register Name	Address	Access	Format	Description
AlgorithmControl	0x54	R/W	[7:0]	[0] StandbyEnable. 1 = Enable Standby state [1] RawDataEnable. 1 = Raw data provided in MX, MY, MZ, AX, AY, AZ, GX, GY, & GZ. 0 = Scaled sensor data. [2] HPRoutput. 1 = Heading, pitch, and roll output in QX, QY, & QZ. QW = 0.0. 0 = Quaternion outputs. [3] 6-AxisEnable (rev 1.2 or higher firmware only) 1 = 6-axis sensor fusion 0 = 9-axis sensor fusion [5] ENUoutputEnable. 1 = ENU output 0 = NED output [6] DisableGyroWhenStill. 1 = Gyro off during stillness 0 = Gyro stays on during stillness. [7] Parameter Transfer. 1 = initiate Parameter Transfer 0 = terminate Parameter Transfer
LoadParamByte0	0x60	R/W	Float 8	Parameter value to be loaded – LSB
LoadParamByte1	0x61	R/W	Float 8	Parameter value to be loaded – LSB + 1
LoadParamByte2	0x62	R/W	Float 8	Parameter value to be loaded – MSB – 1
LoadParamByte3	0x63	R/W	Float 8	Parameter value to be loaded – MSB
ParamRequest	0x64	R/W	[7:0]	Bits [0] – [6] provide the parameter number to be uploaded or retrieved. [7] Load/Save bit. 1 = Load, 0 = Save.

ParamAcknowledge	0x3A	R/O	[7:0]	Bits [0] – [6] provide the parameter number that was uploaded or retrieved. [7] Load/Retrieve bit. 1 = Load, 0 = Retrieve.
RetrieveParamByte0	0x3B	R/O	Float 8	Parameter value read from Sentral – LSB
RetrieveParamByte1	0x3C	R/O	Float 8	Parameter value read from Sentral – LSB + 1
RetrieveParamByte2	0x3D	R/O	Float 8	Parameter value read from Sentral – MSB – 1
RetrieveParamByte3	0x3E	R/O	Float 8	Parameter value read from Sentral – MSB

The parameter transfer process is invoked and terminated by appropriately setting the ParamTransfer bit in the AlgorithmControl register. Ten (10) registers are used for the transfer and for handshaking between SENtral and the host. One set of four registers is allocated to upload a parameter value to SENtral, and another set of four registers is used to retrieve a currently saved parameter from SENtral. Values shorter than four bytes can be transferred using only some of the registers. Two registers implement the handshake mechanism between SENtral and the host. Note that data is stored in little Endian format.

### Parameter Load

Figure A3-1 shows the Parameter Load process by which the host loads parameter data into SENtral.

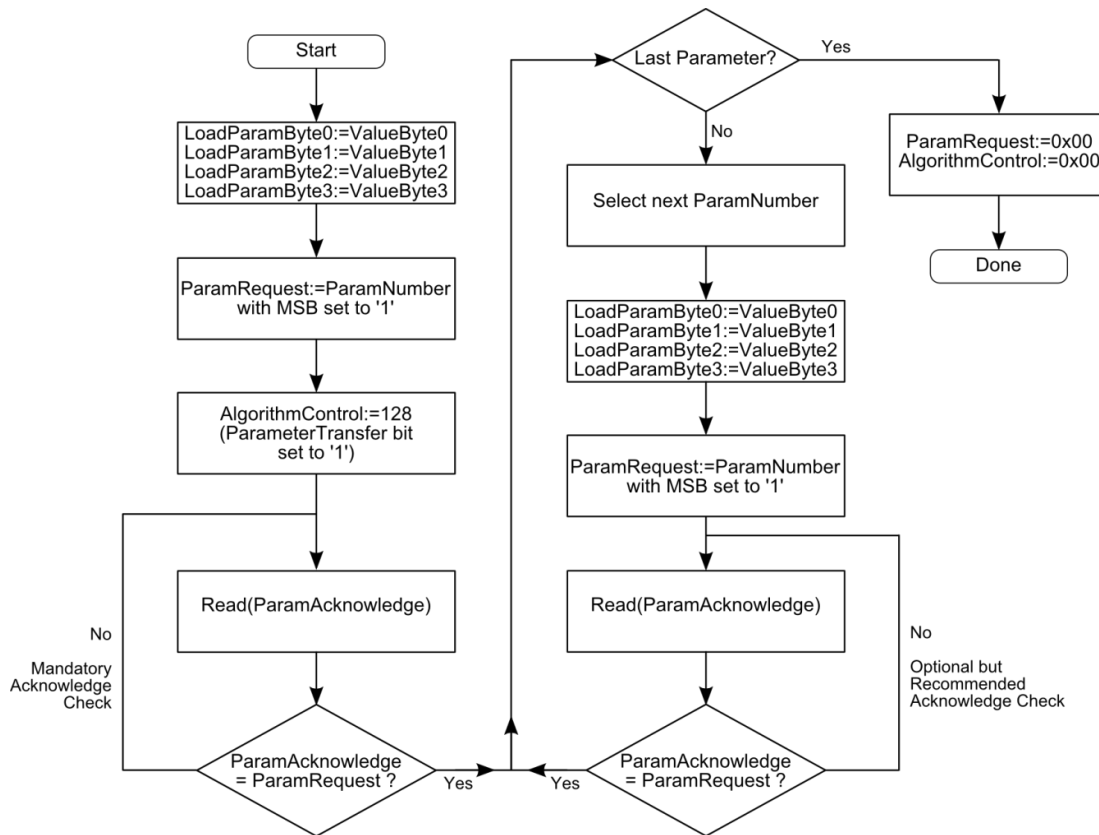

Figure A3-1: Parameter Load Process

Initially the parameter values must be written into the LoadParamByte registers followed by sending a non-zero parameter number into the ParamRequest register. The parameter numbers are given in Table A3-2. **The MSB of the ParamRequest register should be set to '1' to indicate a Load procedure.** All five bytes can be written using a single I<sup>2</sup>C transaction. **AFTER** the first parameter is written, the ParamTransfer bit in the AlgorithmControl register must be set to '1'. Sentral acknowledges receipt of a parameter value by setting ParamAcknowledge equal to ParamRequest, and the host should check the ParamAcknowledge register after writing the first parameter.

Once SENtral acknowledges successfully uploading the first parameter, the host can begin writing the remaining parameters in a loop. Reading the ParamAcknowledge register is optional for subsequent parameters. The host terminates the load procedure by setting the ParamRequest register to 0x00 and the AlgorithmControl register's ParamTransfer bit to '0'.

## Parameter Retrieve

The Parameter Retrieve flowchart is given in Figure A3-2.

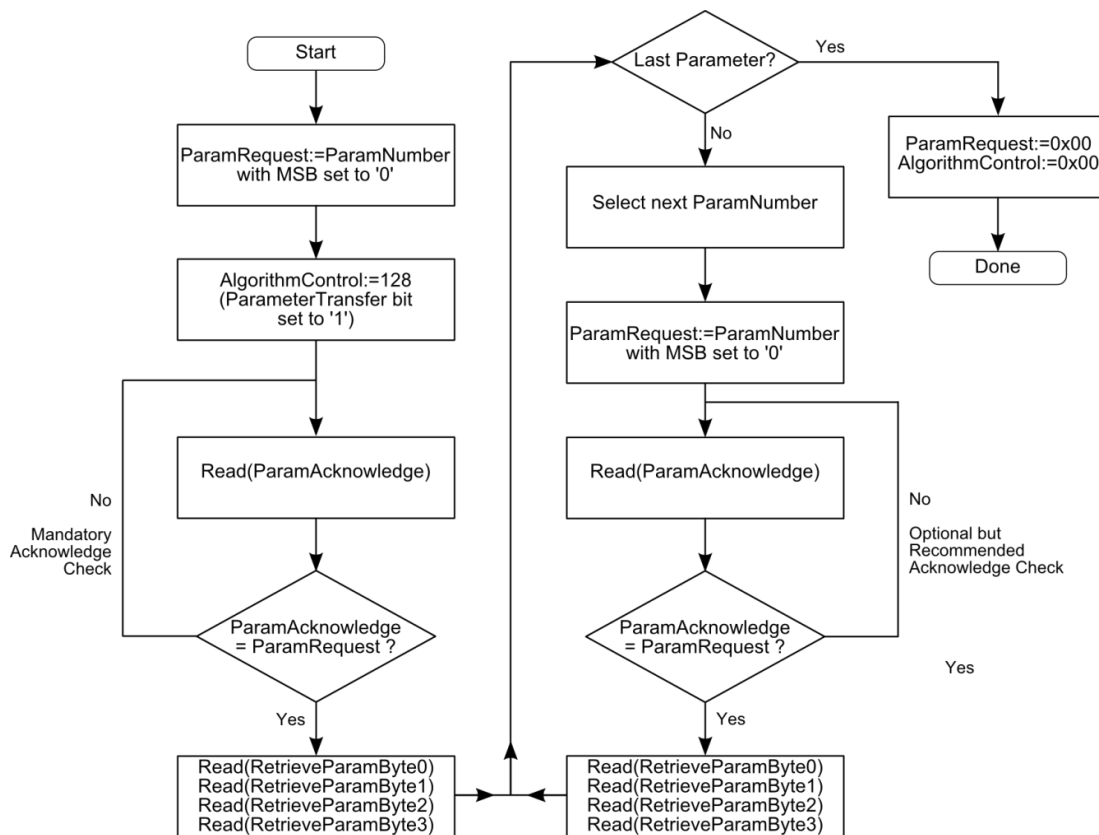

Figure A3-2: Parameter Retrieve Process

The process is initiated by the host writing to the ParamRequest register the desired (non-zero) parameter number. **The MSB of ParamRequest register should be '0' to indicate a Retrieve procedure.** After writing to the ParamRequest register, the ParamTransfer bit in the AlgorithmControl register must be set to '1'. Next, the host should perform repetitive reads of the ParamAcknowledge register until it contains the requested parameter number. Now the host can read the RetrieveParamByte registers to obtain the parameter value. Note the host can read the ParamAcknowledge and RetrieveParamByte registers using a single five-byte read transaction. Also, the RetrieveParamByte values are given in little Endian format, such that RetrieveParamByte3 contains the least significant byte of the parameter's 4-byte float value. The host can continue reading other parameters by varying (normally incrementing) the parameter number contained in the ParamRequest registers. Reading the ParamAcknowledge register is optional for subsequent parameters. The procedure is terminated by the host writing 0x00 to the ParamRequest and AlgorithmControl registers.

### Interleaving Parameter Load and Retrieve

The host can interleave the Parameter Load and Parameter Retrieve processes during a single process invocation. This can be done for each parameter by setting the MSB bit of the



ParamRequest register appropriately. Note that SENtral can be copying a new value into a RetrieveParamByte register while a Parameter Load operation is requested. Interleaving can be utilized by the host as an additional check that the parameter value was updated correctly.

## Parameters

The parameter numbers and associated names are given below in Table A3-2. A discussion on the WarmStart, SensorRange, and DriverID parameters follows.

**Table A3-2: Parameter Numbers**

Parameter Number	Parameter Name	ParamRequest Value	
		Load	Retrieve
1 – 35	WarmStart[1] to WarmStart[35]	0x81 to 0xA3	0x01 to 0x23
36 – 73	Reserved		
74	SensorRange[mag:accel]	0xCA	0x4A
75	SensorRange[gyro]	0xCB	0x4B
77	DriverID[mag:accel]	--	0x4D
78	DriverID[gyro]		0x4E
80	AlgorithmID	--	0x50

### WarmStart

A significant number of parameters are used in the SENtral algorithm as it executes, and these parameters are refined as the SENtral device is used. These include parameters associated with SENtral’s continuous background calibration function and gyro bias correction. When SENtral is powered down or otherwise re-initialized, these parameters also are re-initialized and the parameter refinement process must start over. The parameter transfer process provides the ability to save these parameters to the host as they are refined, and to reload them if the parameters within SENtral are re-initialized. Thus, if the WarmStart parameters periodically are retrieved from SENtral and saved by the host, it is possible to effectively warm-start SENtral after it is re-initialized by reloading the WarmStart parameters into SENtral that previously were saved to the host.

To effectively enable a warm-start process, it is necessary to periodically save all 35 WarmStart parameters, and to reload all of them after SENtral is re-initialized.

## SensorRange

The dynamic ranges of the sensors used in conjunction with SENtral normally are set as part of the Configuration File. Typically the gyroscope will be set to 2000 dps, the accelerometer to  $\pm 2$  g or  $\pm 4$  g, and the magnetometer to  $\pm 1000$   $\mu$ T. However, there may be instances when it is desirable to change the dynamic range. For instance, if SENtral will be used in an application with frequent shock, such as jogging, it may be necessary to increase the accelerometer range to something greater than  $\pm 4$  g.

SensorRange[mag:accel] loads or retrieves the magnetometer range data in ParamByte0 and ParamByte1, while the accelerometer range data is in ParamByte2 and ParamByte3. For example, a likely readout for SensorRange[mag:accel] in the 4x RetrieveParamByte registers is 0xE8030200, corresponding to a magnetometer dynamic range of 0x03E8 ( $\pm 1000$   $\mu$ T) and an accelerometer dynamic range of 0x0002 ( $\pm 2$  g). SensorRange[gyro] loads or retrieves the gyroscope range in ParamByte0 and ParamByte1, while ParamByte2 and ParamByte3 are reserved and should be 0x00.

## DriverID and AlgorithmID

Sensor driver and algorithm revision information can be retrieved using the Parameter Transfer process. Table A3-3 indicates how these parameters are defined. ParameterBytes 2 and 3 for Parameter Numbers 78 and 80 are 0x00 and reserved for future use.

**Table A3-3: DriverID & AlgorithmID Definition**

Parameter Number	Parameter Name	Parameter Byte	Usage
77	DriverID[mag:accel]	0	Mag Driver Revision
		1	Mag Driver ID
		2	Accel Driver Revision
		3	Accel Driver ID
78	DriverID[gyro]	0	Gyro Driver Revision
		1	Gyro Driver ID
80	AlgorithmID	0	Algorithm Revision, Minor
		1	Algorithm Revision, Major

# Appendix IV – Sample Schematic Set

The schematics provided are for a complete Bluetooth-enabled device incorporating SENtral and either an ST LSM9DS0 9-axis sensor or an ST LSM330 gyro/accel combo sensor with an AKM AK8963C magnetometer. Except for the last schematic, the schematics are common regardless of sensors.

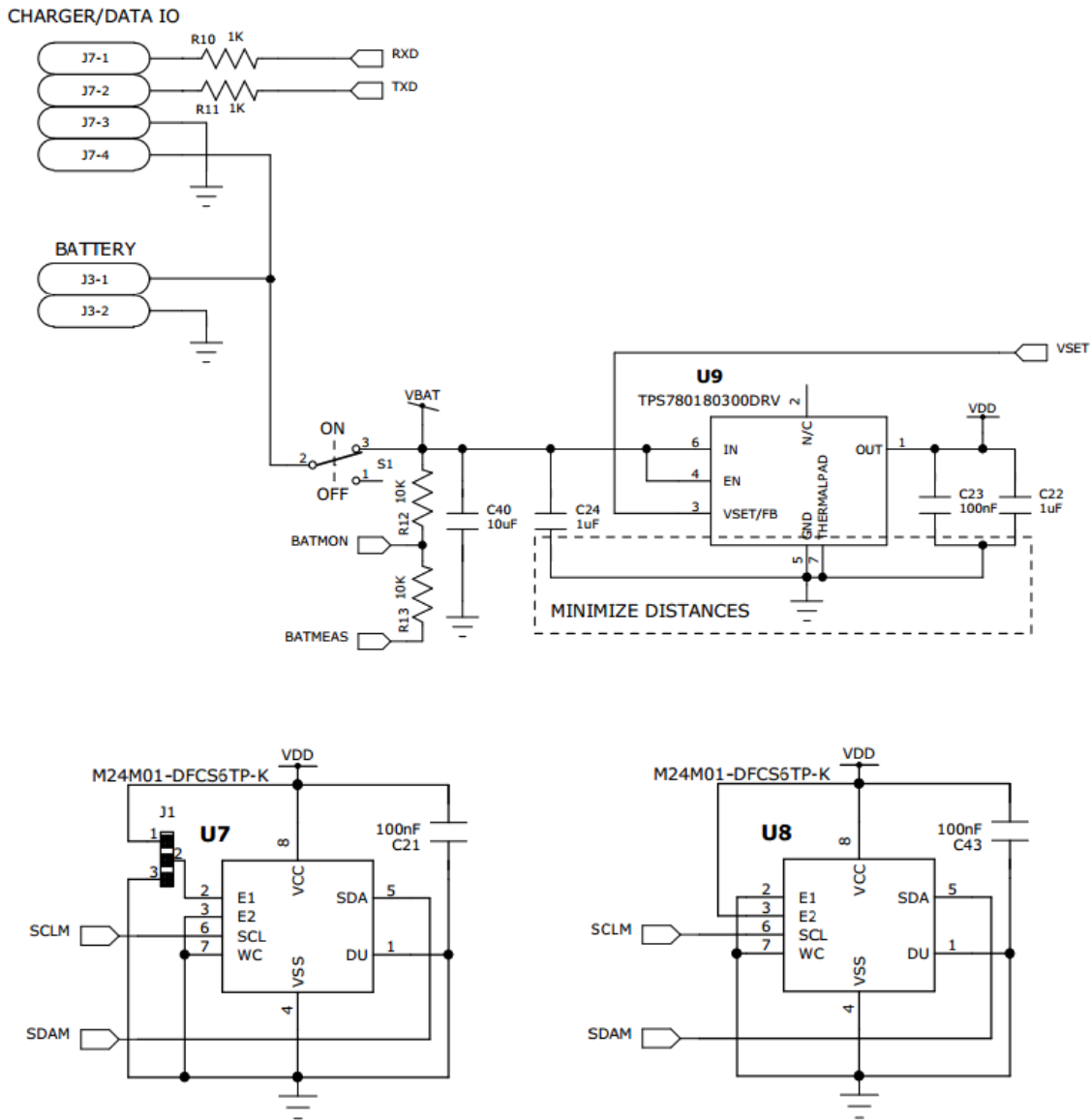

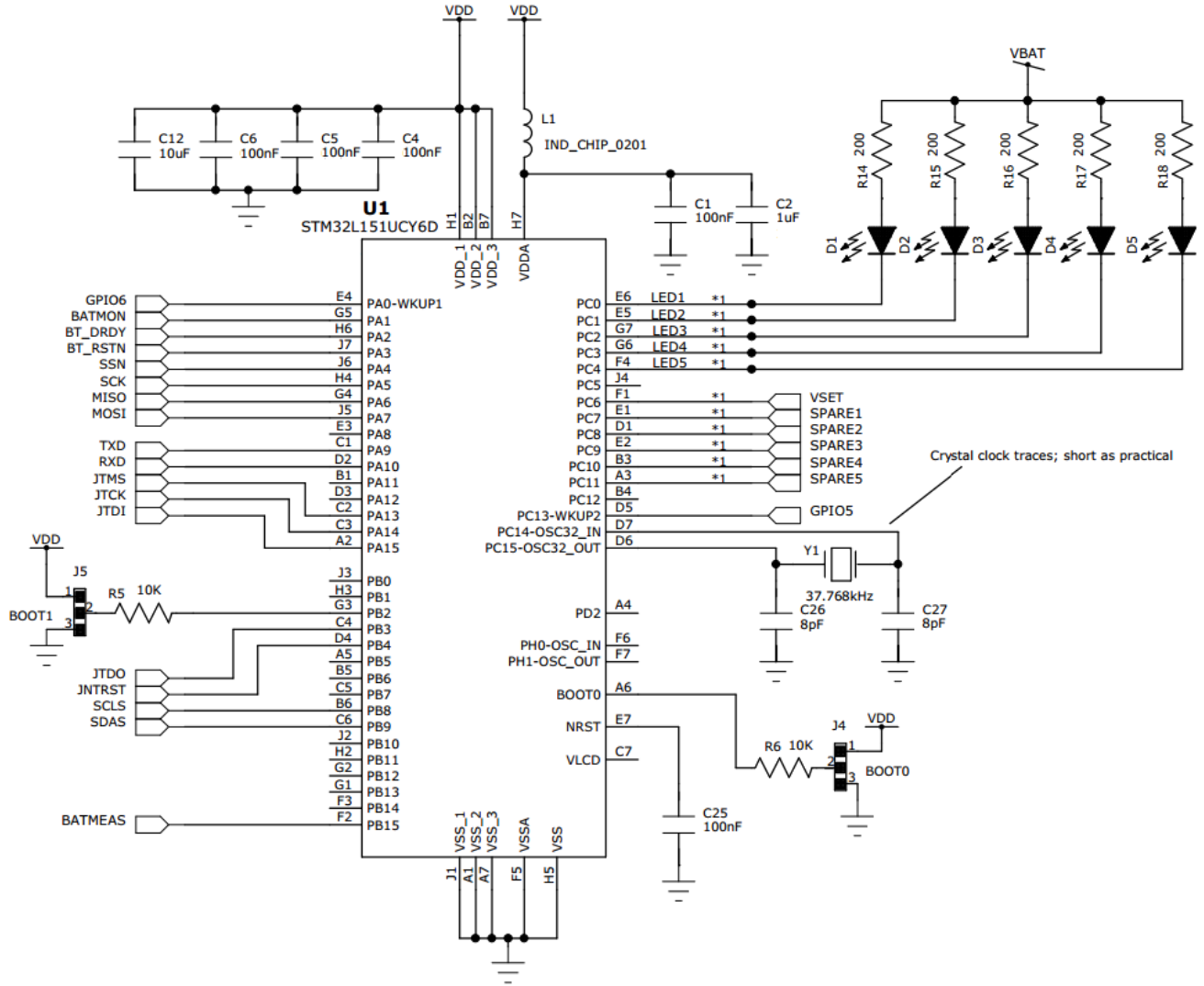

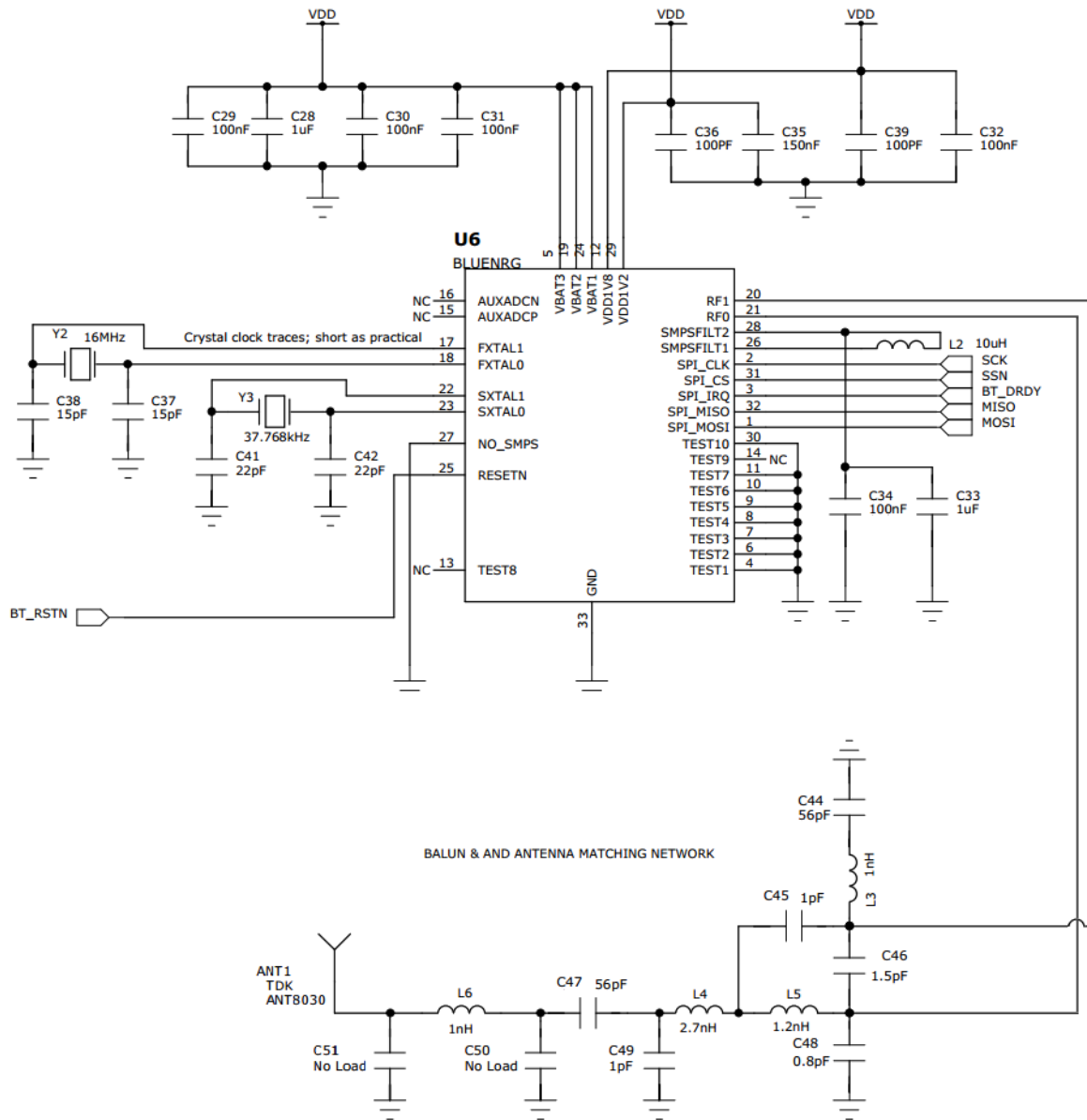

There are 2 sensor layouts shown on this page.  
 Only one should be used, or the OEM may select  
 a different sensor set and generate their own layout.

### ST LSM9DS0

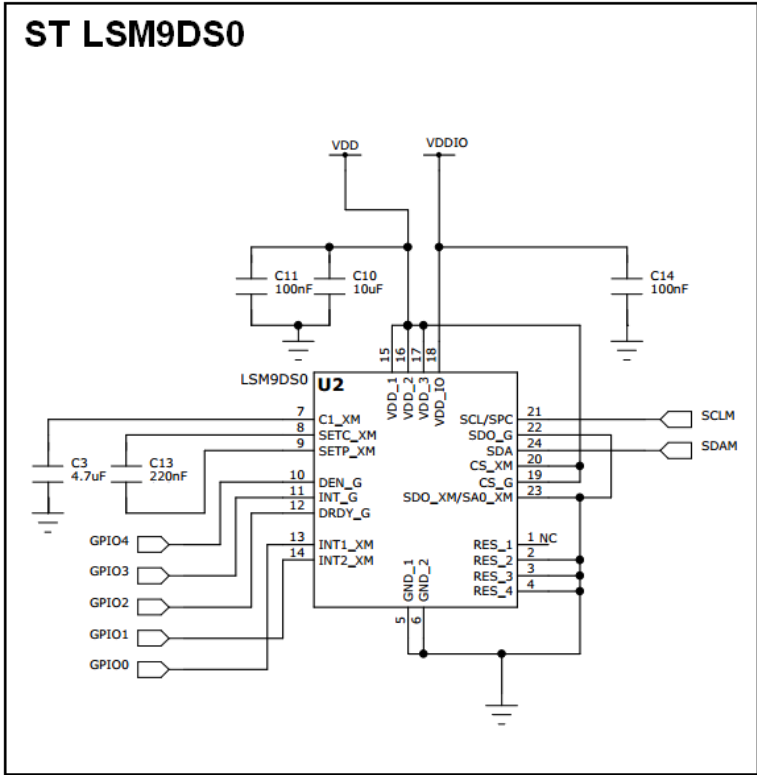

### AKM AK8963C & ST LSM330

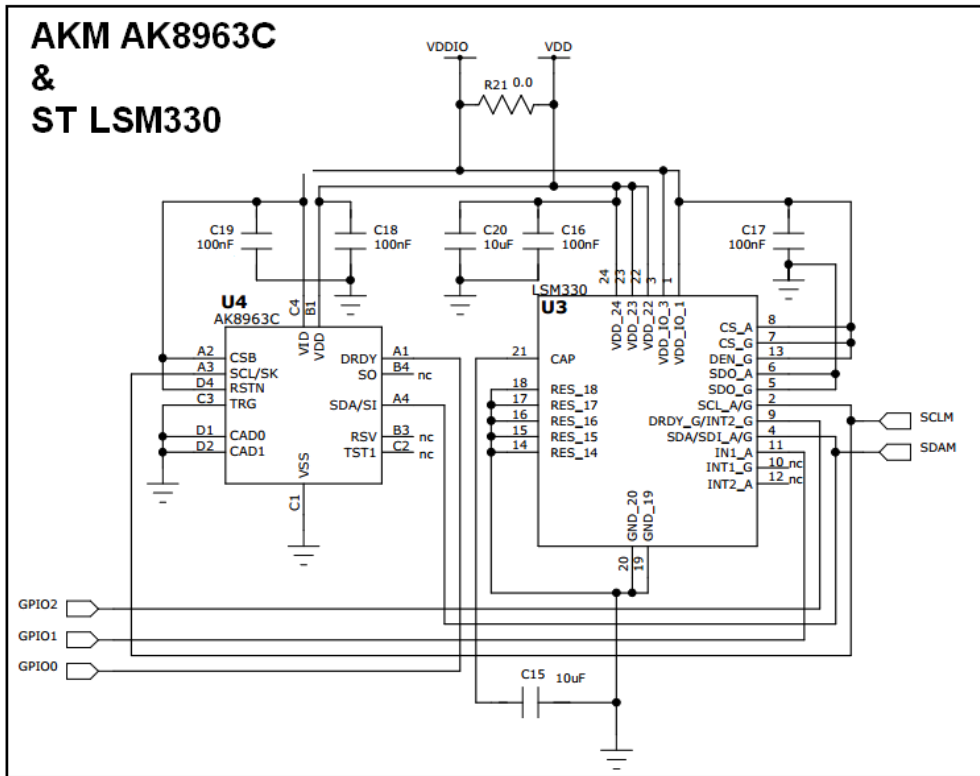

©2013 PNI Sensor Corporation. All Rights Reserved.

Reproduction, adaptation, or translation without prior written permission is prohibited, except as allowed under copyright laws.

Revised April 2014: for the most recent version visit our website at [www.pnicorp.com](http://www.pnicorp.com)

PNI Sensor Corporation  
2331 Circadian Way  
Santa Rosa, CA 95407, USA  
Tel: (707) 566-2260  
Fax: (707) 566-2261

**Warranty and Limitation of Liability.** PNI Sensor Corporation ("PNI") manufactures its Products from parts and components that are new or equivalent to new in performance. PNI warrants that each Product to be delivered hereunder, if properly used, will, for ninety (90) days following the date of shipment unless a different warranty time period for such Product is specified: (i) in PNI's Price List in effect at time of order acceptance; or (ii) on PNI's web site ([www.pnicorp.com](http://www.pnicorp.com)) at time of order acceptance, be free from defects in material and workmanship and will operate in accordance with PNI's published specifications and documentation for the Product in effect at time of order. PNI will make no changes to the specifications or manufacturing processes that affect form, fit, or function of the Product without written notice to the Customer, however, PNI may at any time, without such notice, make minor changes to specifications or manufacturing processes that do not affect the form, fit, or function of the Product. This warranty will be void if the Products' serial number, or other identification marks have been defaced, damaged, or removed. This warranty does not cover wear and tear due to normal use, or damage to the Product as the result of improper usage, neglect of care, alteration, accident, or unauthorized repair.

**THE ABOVE WARRANTY IS IN LIEU OF ANY OTHER WARRANTY, WHETHER EXPRESS, IMPLIED, OR STATUTORY, INCLUDING, BUT NOT LIMITED TO, ANY WARRANTY OF MERCHANTABILITY, FITNESS FOR ANY PARTICULAR PURPOSE, OR ANY WARRANTY OTHERWISE ARISING OUT OF ANY PROPOSAL, SPECIFICATION, OR SAMPLE. PNI NEITHER ASSUMES NOR AUTHORIZES ANY PERSON TO ASSUME FOR IT ANY OTHER LIABILITY.**

If any Product furnished hereunder fails to conform to the above warranty, Customer's sole and exclusive remedy and PNI's sole and exclusive liability will be, at PNI's option, to repair, replace, or credit Customer's account with an amount equal to the price paid for any such Product which fails during the applicable warranty period provided that (i) Customer promptly notifies PNI in writing that such Product is defective and furnishes an explanation of the deficiency; (ii) such Product is returned to PNI's service facility at Customer's risk and expense; and (iii) PNI is satisfied that claimed deficiencies exist and were not caused by accident, misuse, neglect, alteration, repair, improper installation, or improper testing. If a Product is defective, transportation charges for the return of the Product to Customer within the United States and Canada will be paid by PNI. For all other locations, the warranty excludes all costs of shipping, customs clearance, and other related charges. PNI will have a reasonable time to make repairs or to replace the Product or to credit Customer's account. PNI warrants any such repaired or replacement Product to be free from defects in material and workmanship on the same terms as the Product originally purchased.

Except for the breach of warranty remedies set forth herein, or for personal injury, PNI shall have no liability for any indirect or speculative damages (including, but not limited to, consequential, incidental, punitive and special damages) relating to the use of or inability to use this Product, whether arising out of contract, negligence, tort, or under any warranty theory, or for infringement of any other party's intellectual property rights, irrespective of whether PNI had advance notice of the possibility of any such damages, including, but not limited to, loss of use, revenue or profit. In no event shall PNI's total liability for all claims regarding a Product exceed the price paid for the Product. PNI neither assumes nor authorizes any person to assume for it any other liabilities.

Some states and provinces do not allow limitations on how long an implied warranty lasts or the exclusion or limitation of incidental or consequential damages, so the above limitations or exclusions may not apply to you. This warranty gives you specific legal rights and you may have other rights that vary by state or province.

## Revision Control Block

<u>Revision</u>	<u>Description of Change</u>	<u>Effective Date</u>	<u>Approval</u>
G	Initial General Audience Preliminary Release	August 6, 2013	A. Leuzinger
H	Changed current consumption numbers to be based on preliminary measurements, where Operation is now @ Kalman Rate=30 Hz and 7 Hz. Removed footnote on heading accuracy spec. Added more info regarding setting ODR rates. Changed some of the register terminology to be consistent with Register Map revC. Added "Format" column to Table 5-3. In Assembly Guidelines added "Comments specific to Sentral". Changed "Set-Up Program" terminology to "Configuration Tool". Removed "Confidential and Proprietary".	Oct 4, 2013	A. Leuzinger
I	Pertains to svn115. Added Section 3.4 on implementing a dedicated EEPROM. Generally expanded on Section 5.1, Power up and Configuration File Upload and specifically added Section 5.1.3, Config File Image Format. Added Section 5.5 on Troubleshooting. Added Section 4.4 on I2C pull-up resistance. Corrected section 5.1.1 to indicate Bit[1]=1 for good upload. . Added note before Results Register table regarding Endianness. Regarding Section 6, Config Tool, added a note indicating the tool was not available at time publishing of manual, removed "Sensor Range" as this will be settable in a register, indicated the accel calibration matrix needs to be multiplied by -1, and removed "Sensor Bus I2C Data Rate" and sensor bus rate discussion in Section 4.3. (This is set to the sensor's max rate in the driver.) Rotated sample schematic drawings in Appendix II.	Dec. 11, 2013	A. Leuzinger
R01	Pertains to SDK1.0 (svn146), and added note in Section 1 indicating this. Changed picture on front page. Corrected heading, pitch, and role conversion equations in Appendix I. Added ActualMagRate, ActualAccelRate, and ActualGyroRate to Table 5-2, and discussed these in subsequent section. Added Table 5-6: Configuration File Data Structure. Remove Fig. 4-4 regarding EnRegAddr. In Section 5.2, removed recommendation to immediately check Actual[sensor]Rate registers after setting them. In Section 6, removed note about unavailability of Configuration Tool and added link to Tool's website, clarified that a zip file would be downloaded when <Generate> is selected, and discussed the .cfg file.	Jan. 16, 2014	A. Leuzinger
R02	Pertains to SDK1.1.3285. In Table 2-3, changed current consumption to 100-300 uA. In Section 4.2.1, changed the notation in the figures so not every bit begins with "A". Added sentence at beginning of Section 5 regarding Little Endian formatting. Split Section 5.2 into two sections, and somewhat revised these sections. Added note in Section 5.2 about requirement to set [Sensor]Rate registers to non-zero values. Corrected Table 5-1 to indicate a '1' on bit [2] indicates "CRC of EEPROM is <i>incorrect</i> ." Moved Section 5.1.3 on Config File Image to Appendix I and renumbered appendices. In Section 6, added note about "GS and M&M Configuration".	Feb. 20, 2014	A. Leuzinger



R03	Pertains to both SDK 1.1 (build 3285) and SDK 1.2 (build 3639). Added Appendix III, Parameter Transfer. Fixed note in Fig. 7-1. In Section 5.6.2, added discussion of RAMVersion registers and added Table 5-13.	Apr. 16, 2014	A. Leuzinger
R04	Pg 19, Remove "The file is send one byte at a time, using the UPLoadData register." Add following, "using the UPLoadData register, data can be burst uploaded in 8-byte or 12 bytes groups." Per engineering due to bug in SENTral	6/11/14	D McKenzie
R05	Updated Tables 5-4 and A3-1 to include new features in AlgorithmControl register: bit 5 to enable ENU orientation output and bit 6 to disable gyro when stillness detection is active.  Updated Tabe5-13 with rel1.3 information.	6/16/14	R. Thompson D. McKenzie
R06	Updated Rotation to DCM calculation in cells (2,3) and (3,2)	7/2/14	R. Thompson
R07	Updated system diagram, corrected outdated abbreviation for kilobit		D McKenzie