

SENtral

MOTION COPROCESSOR

SENtral™

Motion Coprocessor
A powerfully freeing way to do sensor fusion on mobile devices.

For unparalleled sensor fusion that consumes **only 1% as much power** as other processors.

SENtral™ is a powerfully freeing way of doing sensor fusion.

SENtral saves power. With top-of-the-line embedded **9-axis sensor fusion algorithms**, SENtral is an extremely low-power **motion coprocessor** that completely offloads all motion

sensor management and fusion work from your application processor thus saving you loads of power and a ton of headaches.

Because it's an ultra low-power chip tailor-made for motion sensor fusion, it fuses and continuously auto-calibrates the sensors for always-on requirements. All at a small fraction of the power of even a low power microcontroller sensor hub.

In fact SENtral draws less than 1% of the power of 9-axis sensor fusion running on a Cortex M0 processor running less robust fusion algorithms without continuous auto-calibration. It

moves 9-axis sensor fusion work off the application processor or hub processor onto an ultra low-power coprocessor that's 100 times more power efficient, consuming less than 100 µA.

Essential to the **always-on requirements of motion sensors** in mobile devices and the low power requirements of wearable devices.

SENtral runs "best-in-class" 9-axis sensor fusion with 2 degrees of accuracy. Using continuous auto-calibration technology, it polls individual sensors, integrating, fusing and filtering their data with patented Kalman filter algorithms. SENtral uses much faster sampling rates to deliver output that is lightning quick, accurate and immune to magnetic interference.

Works with any sensor from any manufacturer.

The SENtral motion coprocessor makes it practical because it

supports virtually **all** gyroscopes, accelerometers and magnetic sensors from virtually **any** vendor. It allows you the control and flexibility you need.

Sensor fusion that won't hold you up. For many customers, working out the subtleties of sensor integration, signal enhancement, calibration, magnetic interference, sensor drift and power consumption has proven to be more difficult than first thought. It's time consuming work that can delay product releases.

Made with real world expertise. SENtral's 9-axis sensor fusion technology is custom engineered by PNI Sensor, a leading expert in high end sensor fusion, and is built on a tailor-made ultra low-power coprocessor from EM Microelectronic, experts in producing ultra-low power microelectronic components.



Operating Specifications¹

Accuracy	2° rms	
Data Update Rate	400 Hz Max	
Latency	<1 video frame	
Outputs	Heading, Pitch, & Roll, Rotation Matrix, Quaternions, Sensor Data	
Variable Kalman Update Rate	30Hz Max	
Supply Voltage (V _{DD})	1.6 to 3.3 VDC	
Current Consumption	Peak	800 µA
	Typical	<100 µA at 7Hz Kalman update rate
	Standby	5 µA
I ² C Interface Frequency	100 to 3400 kHz	
Dimensions	1.6 x 1.6 x 0.5 mm	
Operating Temperature	-40 to +85 C	

1. Specifications are subject to change.

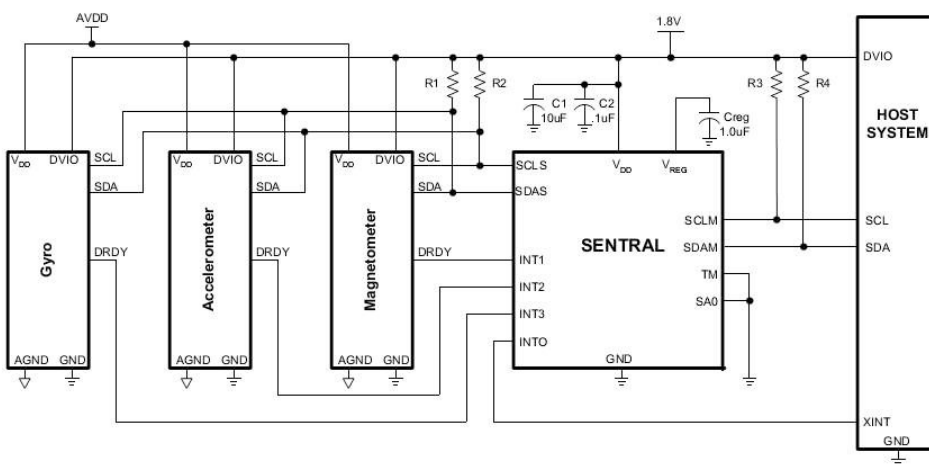

ABOUT PNI SENSOR

PNI Sensor Corporation is the leader in the exacting science of producing pinpoint heading and orientation pinpoint technology and algorithms for the consumer, military, scientific and oceanography communities. Building on decades of patented sensor development, PNI offers highly accurate magneto inductive sensor systems and 9-axis sensor fusion technology. Its products are used in consumer electronics, robotics, surveying, navigation and automotive applications across the globe. To learn more, please visit www.pnicorp.com.

ABOUT EM MICROELECTRONIC – MARIN SA

Founded in 1975, EM Microelectronic is a division of Swatch Group of Switzerland designing and producing several hundreds of millions of miniaturized, ultra-low power integrated circuits annually for more than 150 customers in 35 countries. It is today a leader in supplying electronic circuits for battery operated and field-powered applications.

EM produces standards as well as customer specific ICs for applications in the field of consumer and industrial electronics, automotive, telecommunications, and computer peripherals industries. The company is certified to the international standards ISO9001:2000 and ISO/TS16949:2002. To learn more, please visit www.emmicroelectronic.com.

PNI Sensor Corporation
2331 Circadian Way
Santa Rosa, CA 95407
USA
Phone: +1-707-566-2260
www.pnicorp.com

EM Microelectronic
Rue des Sors 3
2074 Marin
Switzerland
Phone: +41(0)32 755 5111
www.emmicroelectronic.com