

CBP25-V1 Manual

Power Backup Module For HESC & HPSC Series Power Supplies

Manufactured by
Tri-M Technologies Inc.
Engineered Solutions for Embedded Applications

Technical Manual

P/N: CBP25-V1-MAN
Revision: 2 February 2011

TRI-M TECHNOLOGIES INC.

101 - 1530 Kingsway Avenue
Port Coquitlam, BC V3C 6N6
Canada

<http://www.tri-m.com>

Tel 604.945.9565

North America 800.665.5600

Fax 604.945.9566

This manual is for integrators of applications of embedded systems. It contains information on hardware requirements and interconnection to other embedded electronics.

DISCLAIMER

Tri-M Technologies Inc. makes no representations or warranties with respect to the contents of this manual, and specifically disclaims any implied warranties of merchantability or fitness for any particular purpose. Tri-M Technologies Inc. shall under no circumstances be liable for incidental or consequential damages or related expenses resulting from the use of this product, even if it has been notified of the possibility of such damages. Tri-M Technologies Inc. reserves the right to revise this publication from time to time without obligation to notify any person of such revisions. If errors are found, please contact Tri-M Technologies Inc. at the address listed on the title page of this document.

COPYRIGHT © 2010-09-03 TRI-M TECHNOLOGIES INC.

No part of this document may be reproduced, transmitted, transcribed, stored in a retrieval system, or translated into any language or computer language, in any form or by any means, electronic, mechanical, magnetic, optical, chemical, manual, or otherwise, without the express written permission of Tri-M Technologies Inc..

Table of Contents

GENERAL DESCRIPTION	4
INSTALLATION AND OPERATION	5
INSTALLING THE CBP25-V1	5
FIELD PLUG AND FUSE PART NUMBERS	5
CONNECTOR PIN OUTS	5
I2C TEMPERATURE SENSOR	7
CAPACITOR VOLTAGE MONITORING	8
FUSE REPLACEMENT	8
START UP OF AN HESC/HPSC AND CBP25-V1 WITHOUT MAIN POWER AVAILABLE.....	8
DETERMINING POWER HOLD-UP TIME	9
SELF DISCHARGE RATE	10

GENERAL DESCRIPTION

The CBP25-V1 creates a complete UPS system when plugged directly into the bottom of an HESC/HPSC power supply. The CBP25-V1 also can be charged and discharged by other power supplies through the “CH/DIS POWER” and “CH/DIS CTRL” connectors. An external ultracapacitor bank can be connected in parallel with the ultracapacitors on the CBP25-V1 through the use of “EXT CAP POWER” and “EXT CAP CTRL” connectors.

The CBP25-V1 has six 150 farad 2.5V ultracapacitors wired in series for a total of 25 farads up to 15 volts. The CBP25-V1 can supply backup power for over two minutes for a 7 watt load.

Two Voltage Monitoring Controllers (VMCs) per capacitor are employed, one is used to shunt (bypass) current around the capacitor when the capacitor voltage approaches the maximum charge voltage and the second is used to activate the Charge Isolation Mosfets (CIMs) when the capacitor voltage is at the maximum charge voltage. Note: The CBP25-V1 is able to supply backup energy even when the CIMs are in isolation mode.

A set of Discharge Isolation Mosfets (DIMs) on the CBP25-V1 allow the HESC/HPSC power supply to put the CBP25-V1 into isolation mode when the CBP25-V1 output voltage drops below the minimum backup voltage level of the HESC/HPSC power supply.

The CBP25-V1 has a field replaceable automotive style “MINI Blade” fuse is provided to prevent excessively large currents.

Six 25mm x 54mm size Ultra Capacitors are mounted on a PCB along with the DIMs, CIMs, and voltage monitoring controllers. The CBP25-V1 when mounted on an HESC/HPSC can be installed in the Tri-M CanTainer and VersaTainer enclosures.

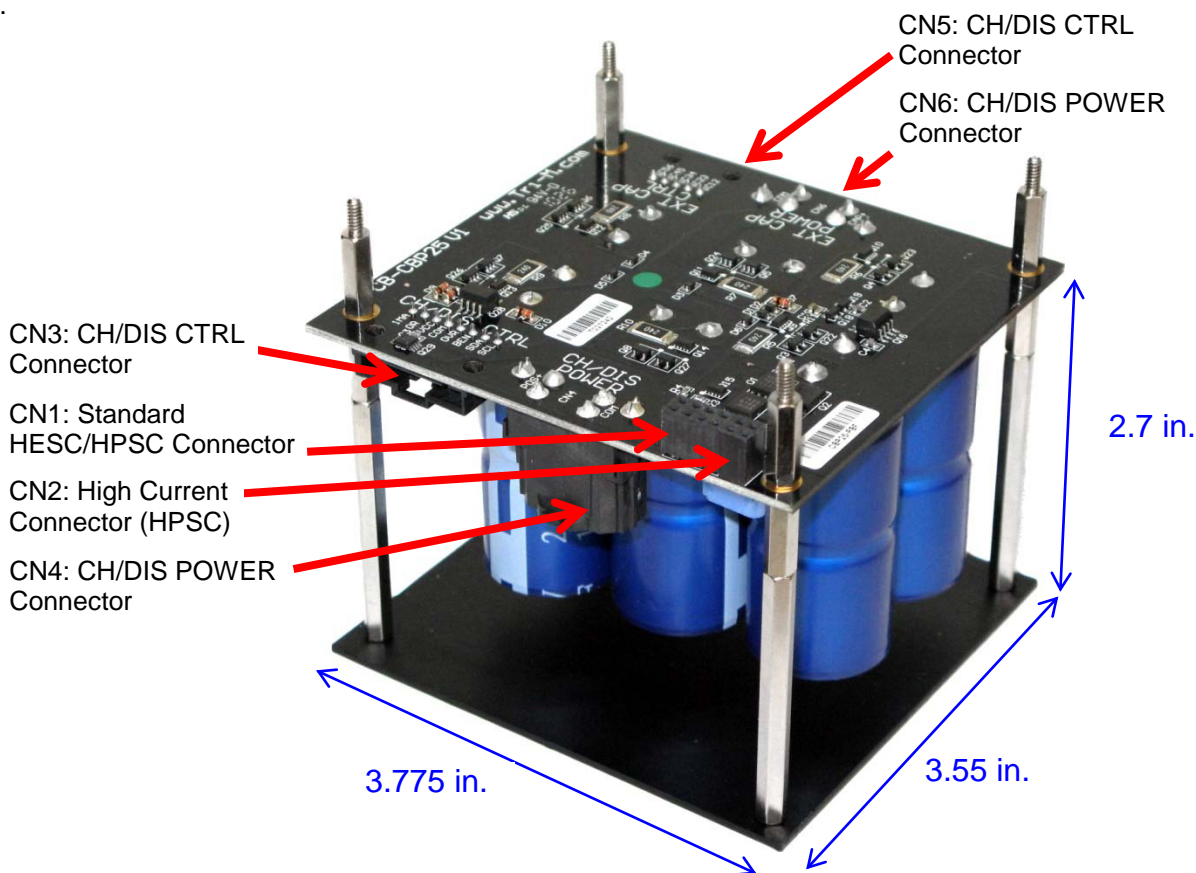

Figure 1 - CBP25-V1 Dimensions

Installation and Operation

Installing the CBP25-V1

The CBP25-V1 mounts directly to the bottom of HESC/HPSC products by plugging CN1 & CN2 into the mating connector on the HESC/HPSC power supply. Spacers (included in optional hardware kit) of 0.6 inch size are used between the CBP25-V1 and the HESC/HPSC power supply it is plugged into.

The CBP25-V1 can be mounted remotely from the HESC/HPSC or some other charger system (such as the Tri-M capUPS charger) and cabled together. Connectors CN3 provides the control signals and CN4 the power connectors for remotely connection.

An external capacitor bank can be added in parallel to the ultra capacitors on the CBP25-V1 to increase available backup energy. Connectors CN5 provides the inter-capacitor node for “capacitor balancing” and CN6 provides the power connection to the external ultra capacitors. Please note that the external ultra capacitor bank must be rated for at least 15.0 volts.

Field Plug and Fuse Part Numbers

Tri-M Part No.	Qty	Description	Part Number	Manufacturer	Part Location
FUSE-MINI-15A	1	Fuse 15A/32V MINI Blade Fast-act	0297015.WXNV	Littelfuse Inc	Plugs into F1
CON-PLUG2-10mm*	2	2 Position Connector Plug	42816-0212	Molex	Plug for CN4 & CN6
CON-PLUG-LOC5*	1	5 Position Locking Plug	50-57-9405	Molex	Plug for CN5
CON-PLUG-LOC8*	1	8 Position Locking Plug	50-57-9408	Molex	Plug for CN3
HW-CRMP-22-24*	13	Connector Term Female 22-24 AWG	16-02-0102	Molex	Crimps for plugs for CN3 & CN5
HW-CRMP-10-12*	4	Conn Term Male 10-12AWG Gold	42815-0012-C	Molex	Crimps for plugs CN4 & CN6

*Optional: Available from Tri-M: Part# HW-CBP25-KIT

Connector Pin Outs

CN1 Standard HESC/HPSC Connector			
Pin#	Signal	Description	Range
1,3	CAP+	Positive connection for charge & discharge.	0 to 16.2VDC *See Note “Operational Voltage”
2, 4	Com	Electrical common	0VDC
5	SDA	I ² C Bidirectional Data Signal to/from HESC/HPSC or remote charger.	Open collector signal pulled to Vcc by HESC/HPSC or remote charger.
6	SCL	I ² C Clock from HESC/HPSC or remote charger.	Open collector signal pulled to Vcc by HESC/HPSC or remote charger.
7	VccCtrl	Control power supplied by HESC/HPSC or remote charger.	5VDC
8	CEN	Low active enable signal.	0V = activate, Vcc = de-activate

CN2 High Current HPSC Connector			
Pin#	Signal	Description	Range
1,3	CAP+	Positive connection for charge & discharge.	0 to 15VDC *See Note “Operational Voltage”
2, 4	Com	Electrical common	0VDC

Note: Operational Voltage – To increase the MTBF the recommended maximum voltage is 14.7V with a temperature compensation of 10mV/degC above 25degC. At 55degC the maximum recommended voltage would therefore be 14.4V.

CN3 CH/DIS CTRL Connector			
Pin#	Signal	Description	Range
1	1mA	1mA current limited supply directly from positive of capacitors.	1mA via current limiting diode.
2	OREN	Enables the DIMs (Discharge Isolation Mosfets) thus turning on the CBP25-V1. If an HESC/HPSC is the charger for the CBP25 then use of this signal should be by a momentary "contact" and not a maintained contact such as an ignition switch so that the HESC/HPSC can de-activate the CBP25-V1 when not required.	1mA current limited. A dry contact between the 1mA signal and OREN can be used.
3	VccCtrl	Control power supplied by HESC/HPSC or remote charger.	5VDC
4	Com	Electrical common	0VDC
5	OVR	Opto-isolated open collector status of any capacitor detected in an overvoltage condition.	Hi-impedance = normal operation. 0V = overvoltage condition exists on one of more capacitors.
6	CEN	Low active enable signal.	0V = activate, VccCtrl = de-activate
7	SDA	I ² C Bidirectional Data Signal to/from HESC/HPSC or remote charger.	Open collector signal pulled to VccCtrl by HESC/HPSC or remote charger.
8	SCL	I ² C Clock from HESC/HPSC or remote charger.	Open collector signal pulled to VccCtrl by HESC/HPSC or remote charger.

CN4 CH/DIS POWER Connector			
Pin#	Signal	Description	Range
1,2	CAP+	Positive connection for charge & discharge.	0 to 16.2VDC
3,4	Com	Electrical common	0VDC

CN5 EXT CAP CTRL Connector			
Pin#	Signal	Description	Range
1	VccSC12	Node between ultracapacitor 1 and 2.	6.25V to 12.5V
2	VccSC23	Node between ultracapacitor 2 and 3.	5V to 10V
3	VccSC34	Node between ultracapacitor 3 and 4.	3.75V to 7.5V
4	VccSC45	Node between ultracapacitor 4 and 5.	2.5V to 5V
5	VccSC56	Node between ultracapacitor 5 and 6.	1.25V to 2.5V

CN6 EXT CAP POWER Connector			
Pin#	Signal	Description	Range
1,2	VccSC1	Positive connection of ultracapacitor bank.	0 to 15VDC
3,4	Com	Electrical common	0VDC

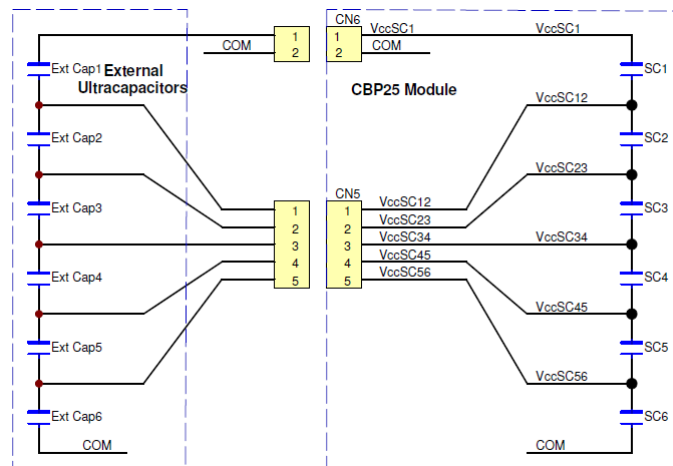

I²C Temperature Sensor

The CBP25-V1 includes an I²C temperature sensor at address 0x4F. The temperature sensor readings can be accessed over the I²C port through connector CN1 or CN3. The temperature readings can be used to decrease the charging voltage as the ambient temperature of the CBP25-V1 increases and to halt all charging if the temperature increases past the maximum (65°C). A negative compensation of 10mV/K (based on starting @ 25°C) will lower the maximum charging voltage 400mV @ 65°C but will extend the life expectancy of operation. The “10” mV/K value can be set into the HESC/HPSC “Temperature Compensation Applied to BattVDef” field in the charge “Cycle 1” settings using the SCU.exe utility. Note that the “Enable compensate the BattVDef voltage for the temperature” radio button must also be enabled for the temperature compensation to be applied (located under the “Cycle 1 – Charge Termination” settings).

When using the SCU.exe utility to configure an HESC/HPSC type of power supply to read the I²C temperature sensor set the “I2C Temperature Sensor Address” to 79 (decimal) and enable the “Address R/W, Enable for Read, Disable For Write” check box (located in the “Temperature Sensor Control” settings).

I ² C Address Byte							
Bit 7	Bit 6	Bit 5	Bit 4	Bit 3	Bit 2	Bit 1	Bit 0
1	0	0	1	1	1	1	R/W
0x4F, (79 dec)							R=1

Note: The I²C temperature readings are only available when VccCtrl power is applied. When using the HESC/HPSC the VccCtrl power is applied whenever the HESC/HPSC has power either from its main input or from the CBP25-V1. Therefore if the CBP25-V1 was enabled through OREN, backup power from the CBP25-V1 would flow to the HESC/HPSC which would in return supply the VccCtrl to the CBP25-V1.

I²C Temperature
Sensor. Address 0x4F



Capacitor Voltage Monitoring

Each capacitor has two Voltage Monitoring Controllers (VMCs). One VMC with a setting of 2.4V is used to shunt (bypass) current around the capacitor through a 24 ohm resistor. The other VMC with a setting of 2.5V generates the OV-DETECT signal which activates the Charge Isolation Mosfets (CIMs) preventing additional charging of the CBP25-V1. The CBP25-V1 can still provide backup power even when the CIMs are activated. To prevent repeated overcharging of the capacitors, the CIMs can only be reset to normal operation by the removal of the charging voltage.

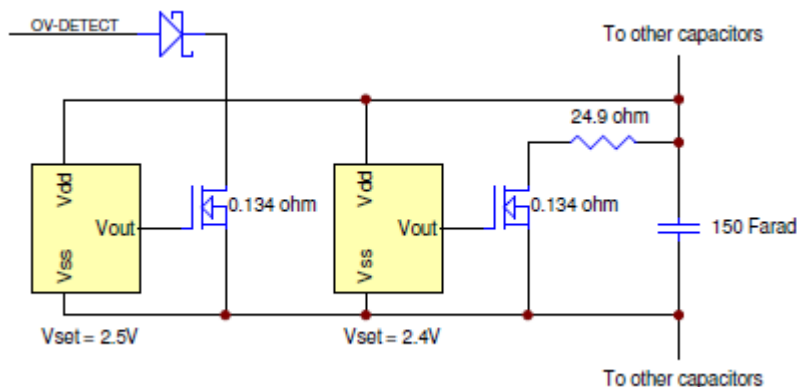

An opto-isolated open collector status (OVR) is available on pin 5 of CN3 (CH/DIS CTRL Connector) of any capacitor activating this OV-DETECT signal.

Fuse Replacement

Each Ultra Capacitor has a rated ESR of 15mohm, and the series ESR of the six of them is less than 90mohm. The application of unregulated charging power or the shorting of the CBP25-V1 output can result in excessive current. An automotive style MINI Blade 15A fuse (F1) allows for field replacing in case of fuse activation. The fuse is located on the opposite side of the PCB of CN1 & CN2. The factory installation of this fuse includes a little RTV on the fuse blades for shock and vibration purposes.

Start up of an HESC/HPSC and CBP25-V1 without Main Power available.

An HESC/HPSC with CBP25-V1 can be powered up without main power available. Connect a momentary dry contact between the 1MA signal (pin 1) and OREN (pin 2) of CN3 (CH/DIS CTRL Connector). The HESC/HPSC with the HESC-UPS18 firmware can be configured to start on capacitor (battery) backup power so that when the momentary dry contact closes and backup power from the CBP25-V1 flows into the HESC/HPSC, the HESC/HPSC recognizes this as a start up request.

Determining Power Hold-Up Time

Energy decrease in capacitor: $\Delta E = \frac{1}{2} C(V_{\max}^2 - V_{\min}^2)$

Where:

- C is the capacitance in farads.
- V_{\max} is the maximum voltage.
- V_{\min} is the cutoff voltage.
- E is energy in joules (watt-seconds)

Therefore for the CBP25-V1, total energy available is $\Delta E = 0.5 * 25 (14.7^2 - 7^2) = 2089$ joules.
(Based on recommended maximum voltage of 14.7V and a cut off voltage of 7V).

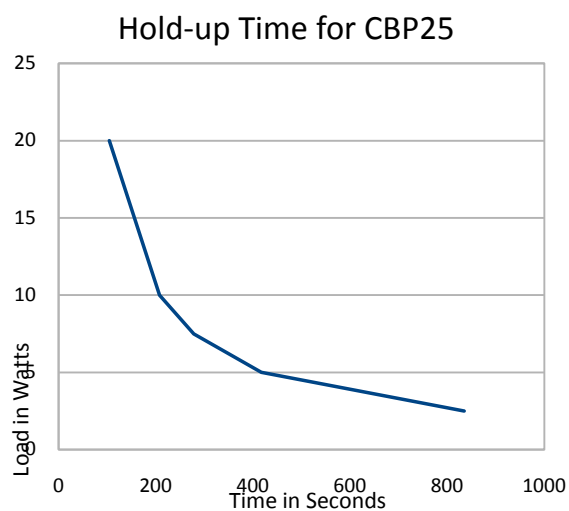

Load in Watts	Holdup Time in Seconds
2.5	835
5	417
7.5	278
10	208
20	104

Self Discharge Rate

The self discharge of the CBP25-V1 is largely from leakage current of the ultracapacitors which can vary widely depending on the ambient temperature and the length of time charging was held on the ultracapacitors. The leakage current is a result of the dielectric between the plates passing a small amount of current which causes the voltage across a charged ultracapacitor to decay over time.

Due to the extremely large surface area of the electrode in the ultracapacitors the time constant of the last 0.5% of the electrode area is extremely long due to the pore size and geometry. The specified leakage current for the ultracapacitors in the CBP25-V1 is 0.3mA and is a measurement of the leakage current after holding the device at the rated voltage for 72 hours continuous at room temperature (25degC). The longer the ultracapacitor is held on charge the lower the leakage current of the device.

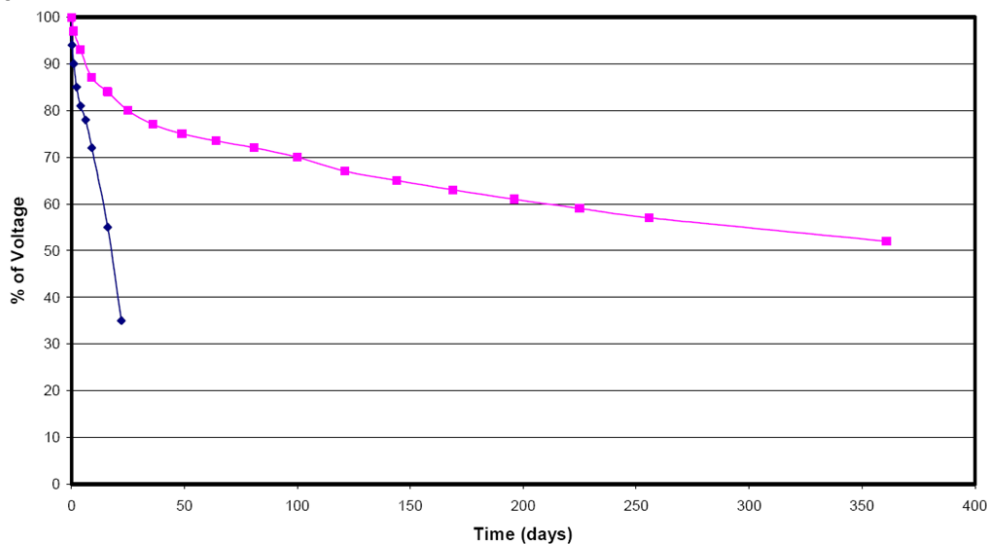

Lower temperatures also decrease leakage current.

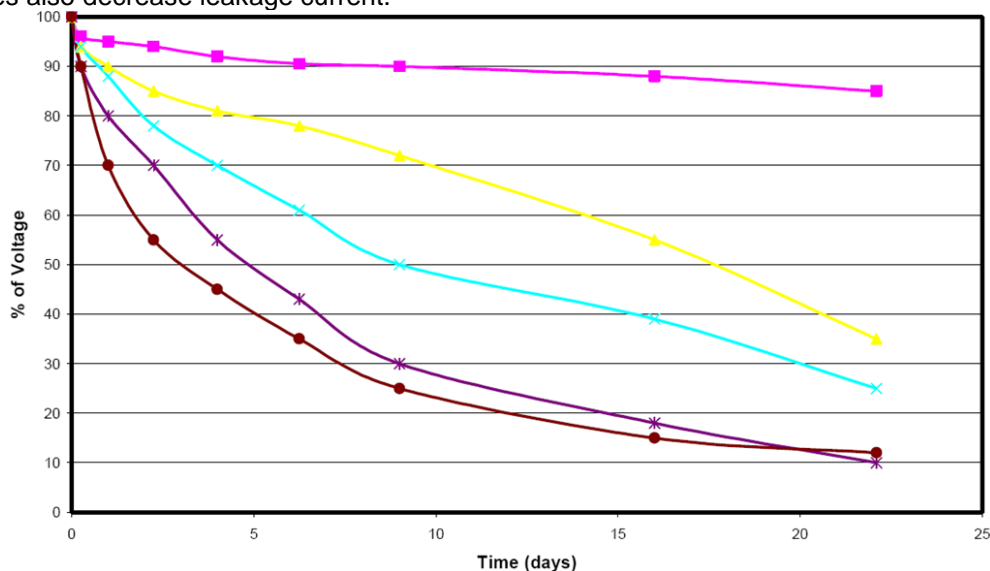

A simple estimate of self discharge is if the ultracapacitors are charged for 72 hours or more and the ambient temperature is 25°C, then the self discharge rate is.

1. 1 percent daily for the first 25 days.
2. 0.1 percent daily after the 25 days.