

**ETX**, Embedded Technology Extended, is a new architecture for industrial applications. It fulfills the requirements for embedded technology by a compact module of most PC functions:

ETX divides a complete motherboard system into two parts physically:

- ETX MODULE - as small as 4.5" x 4" size, carries CPU system and core ASICs
- BASEBOARD - including all I/O connectors, plus some supplementary functions.

### ETX Advantages

- ETX architecture is widely used
- Minimum engineering & evaluation cost
- savings & reduced business risks
- Faster time-to-market
- The systems are scalable by just upgrading the CPU module
- Flexible customer solution board design

### DIMENSIONS

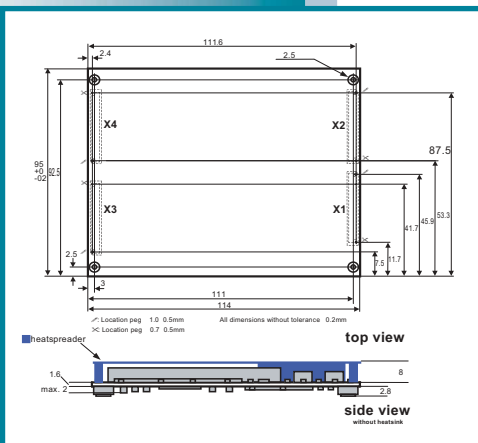

### APPLICATIONS

Digital Content Preview KIOSK  
 Portable Instrument Computers  
 Human Machine Interface Products  
 Point Of Sale (POS)  
 Home Automation  
 Multimedia Entertainment  
 Security Control Terminator  
 Transportation Operation Console

### Fitting Solution for Embedded Application

It occurs a lot that a CPU board doesn't meet industrial PC-based applications, due to unsuitable board size, improper connectors' location or missing functions. The only alternative solution was to develop a completely new design, which is expensive and very time-consuming. Now, IEI presents to you FSEA (Fitting Solution for Embedded Application) which is based on the open standard of ETX technology and designed by JUMPtec.

### Basic Concept of IEI FSEA

ETX modules are scaleable and interchangeable. Thus with a single baseboard, several products can be launched in the same time by the aid of a wide choice of CPU modules.

### M (ETX CPU Module) + N (ETX Baseboard) → M x N Products

In order to enhance the reliability and flexibility of ETX solutions, IEI moves the Ethernet interface from the CPU module to the baseboard. Testing performance reveals that IEI's innovative design produces outstanding results.

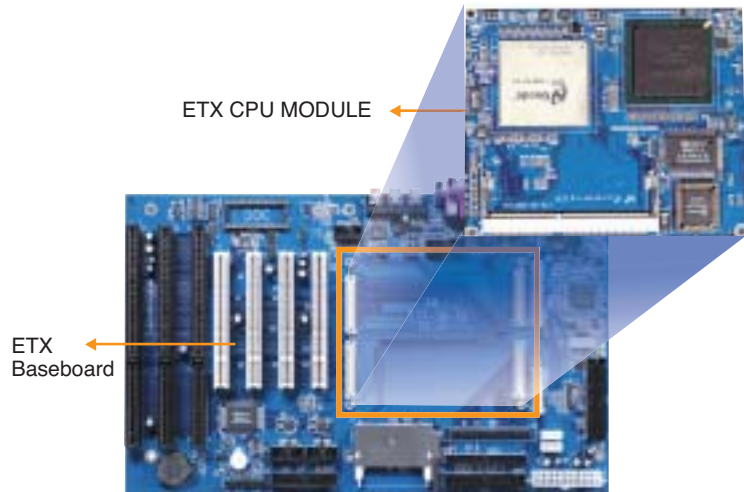

### ETX Module Architecture

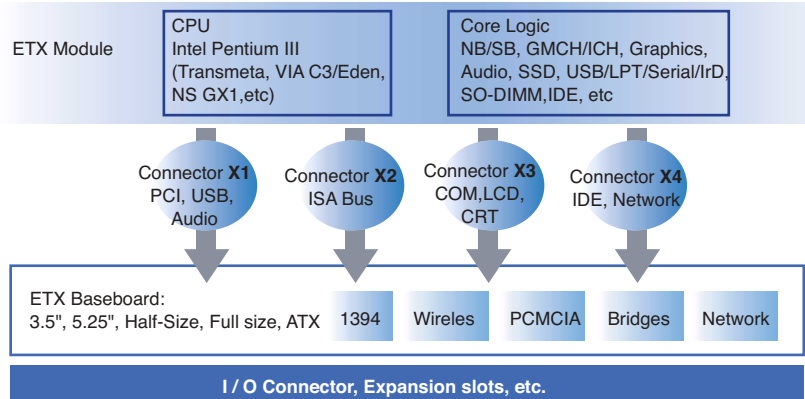

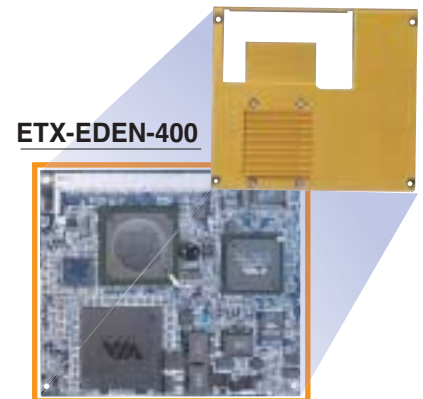
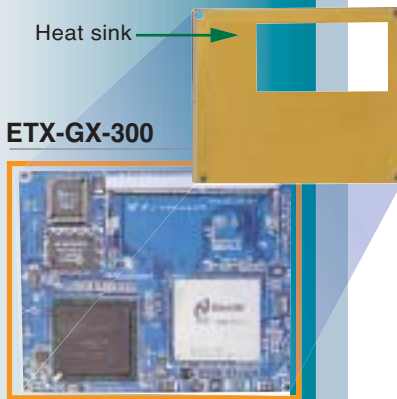

### ETX Module:

ETX modules can be utilized as components by plugging into an application-specific baseboard and putting the core CPU and subsystems together with sound, SVGA, Ethernet and additional I/O. The module connects to the rest of the embedded system through high-density, low profile SMT connectors, which carry both ISA and PCI bus signals as well as dedicated I/O interfaces. The mechanics of the interconnection of an ETX/baseboard system is physically the same height as a one-board solution. ETX modules are interchangeable, allowing system designs to be scaleable.

### Unique design of LAN placement:

In order to avoid any unwanted interruptions, IEI places the LAN function on the baseboard, in order to provide better performance and reliability. Therefore, the chip and transformer won't be affected by noise signals in communication.

### IEI ETX CPU Module

MODELS	ETX-GX-300	ETX-5800-733	ETX-EDEN-400
<b>Processor</b>	NS Geode GX1 300MHz	Transmeta TM5800 733MHz	VIA EDEN 400MHz
<b>Chipset</b>	NS CS5530A	VIA VT82C686B	VIA VT8606/VT82C686B
<b>Graphic Controller</b>	On-Chip VGA	C&T 69030	On-Chip VGA
<b>Graphic Memory</b>	Shared system memory 4MB Max.	4MB RAM on chip	Shared system memory 32MB Max.
<b>LCD Interface</b>	18-bit Single Channel LVDS	36-bit Dual Channel LVDS	18-bit Single Channel LVDS 36-bit Dual Channel LVDS
<b>DRAM Slot</b>	1x 144-pin SO-DIMM support up to 512MB	1x 144-pin SO-DIMM support up to 512MB	1x 144-pin SO-DIMM support up to 512MB
<b>I/O Interface</b>	2x IDE ATA-33 1x LPT/FDD 2x RS-232 2x USB 1.1 1x PS/2	2x IDE ATA-100 1x LPT/FDD 2x RS-232 4x USB 1.1 1x PS/2	2x IDE ATA-100 1x LPT/FDD 2x RS-232 4x USB 1.1 1x PS/2
<b>Audio</b>	AC' 97 Codec	AC' 97 Codec	AC' 97 Codec
<b>WDT</b>	Software Programmable 1~255 sec. System reset	Software Programmable 1~255 sec. System reset	Software Programmable 1~255 sec. System reset
<b>Power Management</b>	APM	ACPI	ACPI
<b>Power Consumption</b>	5V@1.4A; 5VSB@0.2A (NS GX1-300MHz 128MB SO-DIMM)	5V@1.0A; 5VSB@0.1A (TM-5800-733MHz 128MB SO-DIMM)	5V@2.6A; 5VSB@250mA (VA EDEN-400MHz 128MB SO-DIMM)
<b>Operation Temp.</b>	0~60°C	0~60°C	0~60°C
<b>Relative Humidity</b>	0~95%, Non-Condensing	0~95%, Non-Condensing	0~95%, Non-Condensing

Note: For further information about customization Transmeta CPU TM5800 733/867/933 MHz and VIA EDEN CPU, please contact us.

### Ordering Information

<b>ETX-GX-300</b>	NS GX1-300MHz ETX CPU Module
<b>ETX-5800-733</b>	Transmeta TM5800733MHz ETX CPU Module
<b>ETX-EDEN-400</b>	VIA EDEN 400MHz ETX CPU Module

# ETX Series

## IEI ETX Baseboard series



**ETX-DB-7SR**

Full Function ETX Baseboard with LCD/CRT VGA, Audio, DOC, CF II & D I/O



**ETX-DB-ATXR**

ETX Evaluation Baseboard with LCD/CRT VGA, LAN, Audio & D I/O



**ETX-DB-DVR1**

ETX Baseboard with 4 Capture Engine CF II, Dual LAN, Audio & D I/O

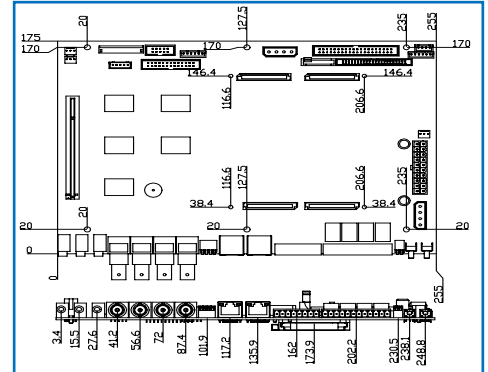
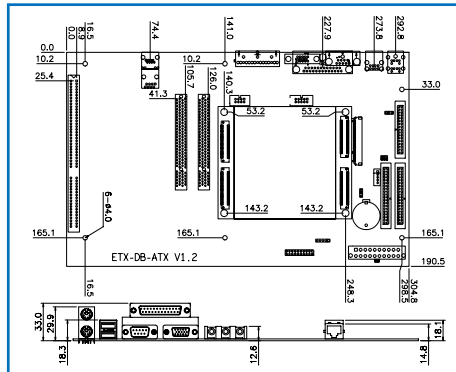
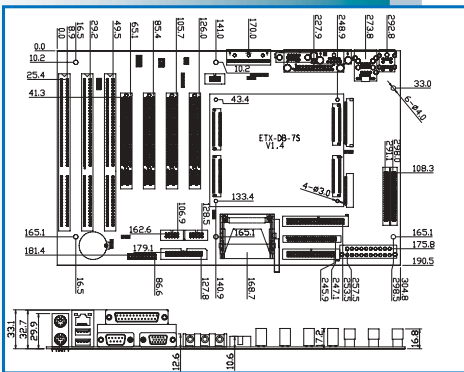

### IEI ETX Customization Flow

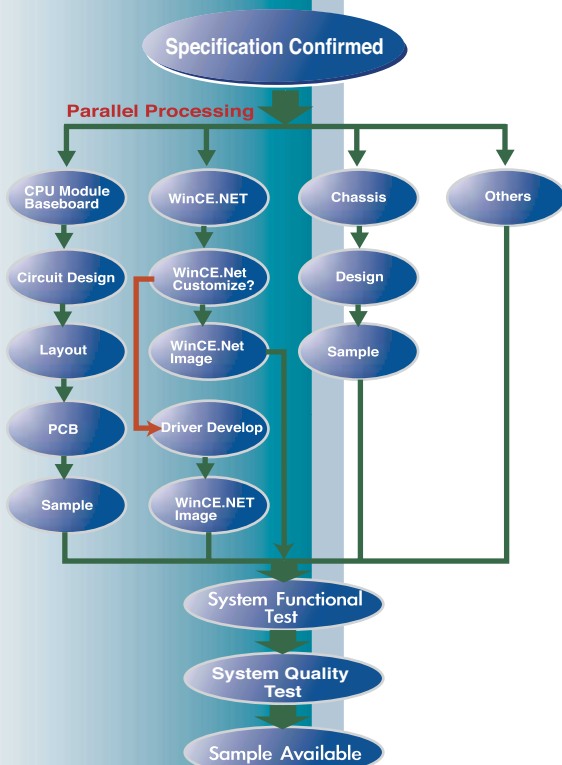

### IEI ETX Baseboard

	ETX-DB-7SR	ETX-DB-ATXR	ETX-DB-DVR1
<b>CPU Module Interface</b>	ETX Form Factor	ETX Form Factor	ETX Form factor
<b>LCD Connector Slot</b>	1 x 20-pin 24bit DFP for LVDS 1 x 30-pin 48bit DFP for LVDS 1 x 44-pin for 24bit TTL 1 x 44-pin for 18bit TTL	1 x 30-pin DFP for LVDS	1 x 20-pin 36bit DFP for LVDS
<b>Extension Slot</b>	4 x PCI, 3 x ISA	2 x PCI, 1 x ISA	1 x PCI
<b>Ethernet Chip</b>	Realtek 8100BL	Realtek 8100BL	2 x Intel 82559
<b>SSD</b>	CompactFlash Type II socket	N/A	CompactFlash Type II socket
<b>Audio</b>	AC'97	AC'97	C-Media (CMI 8738)
<b>Ethernet Connector</b>	1x RJ-45	1 x RJ-45	2x RJ-45
<b>RS232</b>	3	2	1 (TX,RX only)
<b>RS232/422/485</b>	1	N/A	1
<b>KB/MS</b>	2	2	1
<b>LPT</b>	2	1	N/A
<b>VGA</b>	1	1	1
<b>USB</b>	4	4	2
<b>IDE Connector</b>	2	2	2
<b>Floppy</b>	1	1	N/A
<b>DOC</b>	1	N/A	N/A
<b>DIO</b>	4 inputs, 4 outputs	4 inputs, 4 outputs	4 inputs, 4 outputs
<b>IR connector</b>	5 pin-header	5 pin-header	N/A
<b>Capture Chip</b>	N/A	N/A	4 x BT878A
<b>Video Capture Connector</b>	N/A	N/A	4 x BNC connector

### ORDERING INFORMATION

**ETX-DB-7SR**

ATX Size 7 Slots ETX Baseboard with Realtek 8100BL LAN

**ETX-DB-ATXR**

ETX Evaluation Baseboard with Realtek 8100BL LAN

**ETX-DB-DVR1**

ETX DVR Baseboard with Dual Intel® 82559 LAN

# ETX Series

## IEI ETX Module Connector Pin Definition

### X1 ( PCI-Bus, USB & Audio )

PIN	SIGNAL	PIN	SIGNAL
1	GND	2	GND
3	PCICLK3	4	PCICLK4
5	GND	6	GND
7	PCICLK1	8	PCICLK2
9	REQ3#	10	GNT3#
11	GNT2#	12	3.3V
13	REQ2#	14	GNT1#
15	REQ1#	16	3.3V
17	GNT0#	18	RESERVED
19	5V	20	5V
21	SERIRQ	22	REQ0#
23	AD0	24	3.3V
25	AD1	26	AD2
27	AD4	28	AD3
29	AD6	30	AD5
31	CBE0#	32	AD7
33	AD8	34	AD9
35	GND	36	GND
37	AD10	38	LINE-IN-L
39	AD11	40	MIC
41	AD12	42	LINE-IN-R
43	AD13	44	ASVCC
45	AD14	46	LINE-OUT-L
47	AD15	48	ASGND
49	CBE1#	50	LINE-OUT-R
51	5V	52	5V
53	PAR	54	SERR#
55	PERR#	56	RESERVED
57	PME#	58	USB2#
59	LOCK#	60	DEVSEL#
61	TRDY#	62	USB3#
63	IRDY#	64	STOP#
65	FRAME#	66	USB2
67	GND	68	GND
69	AD16	70	CBE2#
71	AD17	72	USB3
73	AD19	74	AD18
75	AD20	76	USB0#
77	AD22	78	AD21
79	AD23	80	USB1#
81	AD24	82	CBE3#
83	5V	84	5V
85	AD25	86	AD26
87	AD28	88	USB0
89	AD27	90	AD29
91	AD30	92	USB1
93	PCIRST#	94	AD31
95	INTC#	96	INTD#
97	INTA#	98	INTB#
99	GND	100	GND

### X2 ( ISA-Bus )

PIN	SIGNAL	PIN	SIGNAL
1	GND	2	GND
3	SD14	4	SD15
5	SD13	6	MASTER#
7	SD12	8	DRQ7
9	SD11	10	DACK7#
11	SD10	12	DRQ6
13	SD9	14	DACK6#
15	SD8	16	DRQ5
17	MEMW#	18	DACK5#
19	MEMR#	20	DRQ0
21	LA17	22	DACK0#
23	LA18	24	IRQ14
25	LA19	26	IIQR15
27	LA20	28	IRQ12
29	LA21	30	IRQ11
31	LA22	32	IRQ10
33	LA23	34	IOCS16#
35	GND	36	GND
37	SBHE#	38	MEMCS16#
39	SA0	40	OSC
41	SA1	42	BALE
43	SA1	44	TC
45	SA3	46	DACK2#
47	SA4	48	IRQ3
49	SA5	50	IRQ4
51	5V	52	5V
53	SA6	54	IRQ5
55	SA7	56	IRQ6
57	SA8	58	IRQ7
59	SA9	60	SYSCLK
61	SA10	62	REFSH#
63	SA11	64	REQ1
65	SA12	66	DACK1#
67	GND	68	GND
69	SA13	70	DRQ3
71	SA14	72	DACK3#
73	SA15	74	IOR#
75	SA16	76	IOW#
77	SA18	78	SA17
79	SA19	80	SMEMR#
81	IOCHRDY	82	AEN
83	5V	84	5V
85	SD0	86	SMEMW#
87	SD2	88	SD1
89	SD3	90	ZOWS#
91	DRQ2	92	SD4
93	SD5	94	IRQ9
95	SD6	96	SD7
97	IOCHK#	98	RSTDRV
99	GND	100	GND

### X3 ( VGA, LCD, Video, COM1, COM2, LPT/Floppy, Irda, Mouse & Keyboard )

PIN	SIGNAL	PIN	SIGNAL
1	GND	2	GND
3	R	4	B
5	CRTHSYNC	6	G
7	CRTVSYNC	8	DDCSCL
9	N.C.	10	DDCSDA
11	TXCLK1-	12	TXOUT13-
13	TXCLK1+	14	TXOUT13+
15	GND	16	GND
17	TXOUT11+	18	TXOUT12+
19	TXOUT11-	20	TXOUT12-
21	GND	22	GND
23	TXOUT03-	24	TXOUT10+
25	TXOUT03+	26	TXOUT10-
27	GND	28	GND
29	TXOUT02-	30	TXCLK0+
31	TXOUT02+	32	TXCLK0-
33	GND	34	GND
35	TXOUT00+	36	TXOUT01+
37	TXOUT00-	38	TXOUT01-
39	5V	40	5V
41	N.C.	42	N.C.
43	N.C.	44	FPENABKL
45	N.C.	46	FPENAVDD
47	TV-CVBS	48	TV-Y
49	TV-SYNC	50	TV-C
51	LPT/FLPY#	52	RESERVED
53	5V	54	GND
55	STB#	56	AFD#
57	RESERVED	58	PD7
59	IRRX	60	ERR#
61	IRTX	62	PD6
63	RXD2	64	INIT#
65	GND	66	GND
67	RTS2#	68	PD5
69	DTR2#	70	SLIN#
71	DCD2#	72	PD4
73	DSR2#	74	PD3
75	CTS2#	76	PD2
77	TXD2	78	PD1
79	RI2#	80	PD0
81	5V	82	5V
83	RXD1	84	ACK#
85	RTS1#	86	BUSY#
87	DTR1#	88	PE
89	DCD1#	90	SLCT
91	DSR1#	92	MSCLK
93	CTS1#	94	MSDATA
95	TXD1	96	KBCLK
97	RI1#	98	KBDATA
99	GND	100	GND

### X4 ( IDE1, IDE2 & Miscellaneous )

PIN	SIGNAL	PIN	SIGNAL
1	GND	2	GND
3	5VSB	4	PWGIN
5	PS_ON	6	SPEAKER
7	PWRBTN#	8	VBAT
9	KBINH	10	N.C.
11	WDTACT#	12	N.C.
13	ROMKBCS#	14	N.C.
15	ROMCS#	16	I2CCLK
17	5V	18	5V
19	OVRRCUR	20	DIOCS#
21	EXTSMI#	22	I2CDATA
23	SMBCLK	24	SMBDATA
25	SIDE_CS3#	26	N.C.
27	SIDE_CS1#	28	DASP_S
29	SIDE_A2	30	PIDE_CS3#
31	SIDE_A0	32	PIDE_CS1#
33	GND	34	GND
35	PDIAG_S	36	PIDE_A2
37	SIDE_A1	38	PIDE_A0
39	SIDE_IRQ#	40	PIDE_A1
41	N.C.	42	N.C.
43	SIDE_DACK#	44	PIDE_IRQ#
45	SIDE_IORDY	46	PIDE_DACK#
47	SIDE_IOR#	48	PIDE_IORDY
49	5V	50	5V
51	SIED_IOW#	52	PIDE_IOR#
53	SIDE_DRQ	54	PIDE_IOW#
55	SIDE_D15	56	PIDE_DRQ
57	SIDE_D0	58	PIDE_D15
59	SIDE_D14	60	PIDE_D0
61	SIDE_D1	62	PIDE_D14
63	SIDE_D13	64	PIDE_D1
65	GND	66	GND
67	SIDE_D2	68	PIDE_D13
69	SIDE_D12	70	PIDE_D2
71	SIDE_D3	72	PIDE_D12
73	SIDE_D11	74	PIDE_D3
75	SIDE_D4	76	PIDE_D11
77	SIDE_D10	78	PIDE_D4
79	SIDE_D5	80	PIDE_D10
81	5V	82	5V
83	SIDE_D9	84	PIDE_D5
85	SIDE_D6	86	PIDE_D9
87	SIDE_D8	88	PIDE_D6
89	RING#	90	N.C.
91	N.C.	92	PIDE_D8
93	N.C.	94	SIDE_D7
95	N.C.	96	PIDE_D7
97	N.C.	98	IDERST#
99	GND	100	GND