

**ETX-DB-DVR1**  
**ETX DVR Baseboard with**  
**10/100 Mbps LAN, VGA, Video Capture,**  
**Audio**  
**Version 1.0**

User Manual Version 1.1

Jul 10, 2003



## **Copyright Notice**

The information in this document is subjected to change without prior notice in order to improve reliability, design and function and does not represent a commitment on the part of the manufacturer.

In no event will the manufacturer be liable for direct, indirect, special, incidental, or consequential damages arising out of the use or inability to use the product or documentation, even if advised of the possibility of such damages.

This document contains proprietary information protected by copyright. All rights are reserved. No part of this manual may be reproduced by any mechanical, electronic, or other means in any form without prior written permission of the manufacturer.

## **Trademarks**

ETX-DB-DVR1 is a registered trademark of ICP Electronics Inc.; IBM PC is a registered trademark of International Business Machines Corporation. Intel is a registered trademark of Intel Corporation. AMI is a registered trademark of American Megatrends Inc. Other product names mentioned herein are used for identification purposes only and may be trademarks and/or registered trademarks of their respective companies.

# Contents

<b>1. Introduction</b> .....	<b>5</b>
1.1 Specifications.....	5
1.2 Package Contents.....	6
<b>2. Installation</b> .....	<b>7</b>
2.1 Layout Diagram & Dimension .....	8
2.2 Clear CMOS Setup .....	10
2.3 RS232 or RS422/485 Selection .....	10
2.4 Video Terminal Resistance Selection .....	10
2.5 LCD Voltage Setting .....	11
2.6 Compact Flash Card Master/Slave Mode Setting.....	11
<b>3. Connection</b> .....	<b>12</b>
3.1 Audio Connectors .....	12
3.2 PCI E-IDE Disk Drive Connector .....	13
3.3 Compact Flash Storage Card Socket (Optional).....	14
3.4 USB Port Connectors.....	15
3.5 ATX Power Connector and Switch.....	15
3.6 Serial Ports .....	17
3.7 Keyboard/Mouse Connector .....	18
3.8 LAN, HDD, Power Status LED Connector .....	18
3.9 Fan Connector .....	19
3.10 VGA Connector.....	19
3.11 AT & IDE Power Connector .....	20
3.12 LAN RJ45 Connector .....	21

3.13	TV Out Connector .....	21
3.14	Video Capture Connector .....	21
3.15	TFT LCD & Inverter Connector .....	22
3.16	Input / Output Device Connector.....	23
3.17	ETX Board X1-X4 Connector.....	25

# 1. Introduction

ETX-DB-DVR1 ATX/AT baseboard is designed for DVR applications. ETX-DB-DVR1 back plane has two network controllers onboard, using Intel 82559 LAN controller, which is a fully integrated 10/100BASE-TX controller with high performance networking function features.

In addition, ETX-DB-DVR1 provides four video capture chips onboard, using Conexant FUSION 878A that is suitable for the DVR System.

## 1.1 Specifications

- **Support System:** Supports standard ETX CPU module.
- **CompactFlash™ interface:** Supports CompactFlash™ Type II socket for Compact Flash Disk or IBM Micro Drive.
- **Intel 82559 LAN Controller:** IEEE 802.3u Auto-Negotiation supports 10BASE-T/100BASE-TX standard. Fast back-to-back transmission support with minimum interframe spacing. Connect the LAN Controller to the LAN through RJ45 connector.
- **Serial Ports:** Two RS232 ports, one RS232 port can be set to RS-422/485 with Auto-Direction technology.
- **Conexant Fusion 878A Video Capture Controller:** Total frame rate is up to 120 frames per second with 4 channels of BNC composite video input and NTSC/PAL/SECAM auto sensing.
- **VGA Controller:** Embedded VGA controller. Screen Resolution: up to 1600x1200 in 256 Colors at 85Hz refresh.
- **Audio:** C-Media CMI-8738 audio controller. Supports stereo line (Left/Right, IN/OUT), MIC-IN, and CD-IN.

## 1.2 Package Contents

- ETX-DB-DVR1 Baseboard x 1
- IDE HDD Cable x 1
- RS-232, 422/485 Cable x 1
- Keyboard & Mouse 6-pin Cable x 1
- VGA 10-pin Cable x 1
- CD-ROM Driver x 1
- User Manual x 1

If any of these items are missing or damaged, please contact the dealer from whom you purchased the product. Save the shipping materials and carton in case you want to ship or store the product in the future.

## **2. Installation**

This chapter describes how to install ETX-DB-DVR1. Follow the unpacking information carefully and refer to the following layout diagram of ETX-DB-DVR1 when necessary.

## 2.1 Layout Diagram & Dimension

### Layout Diagram

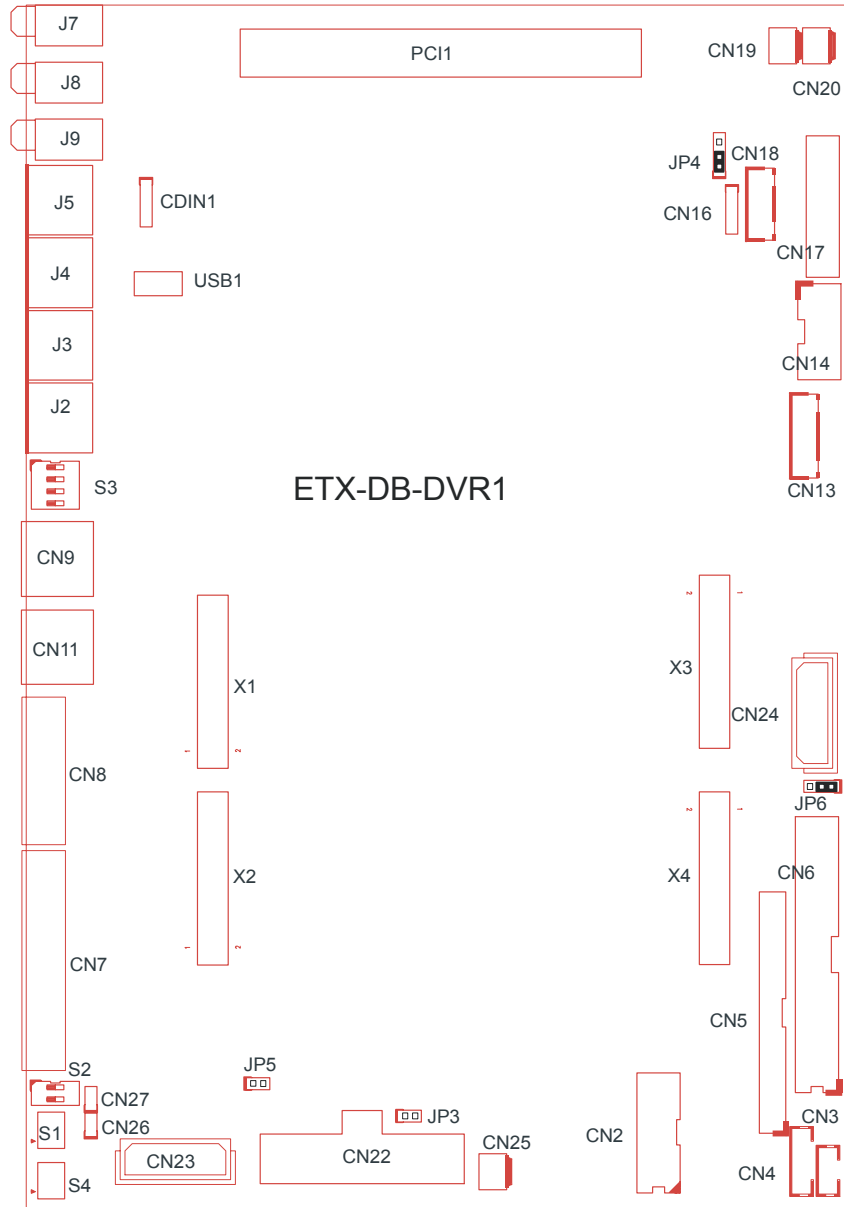

# Dimension

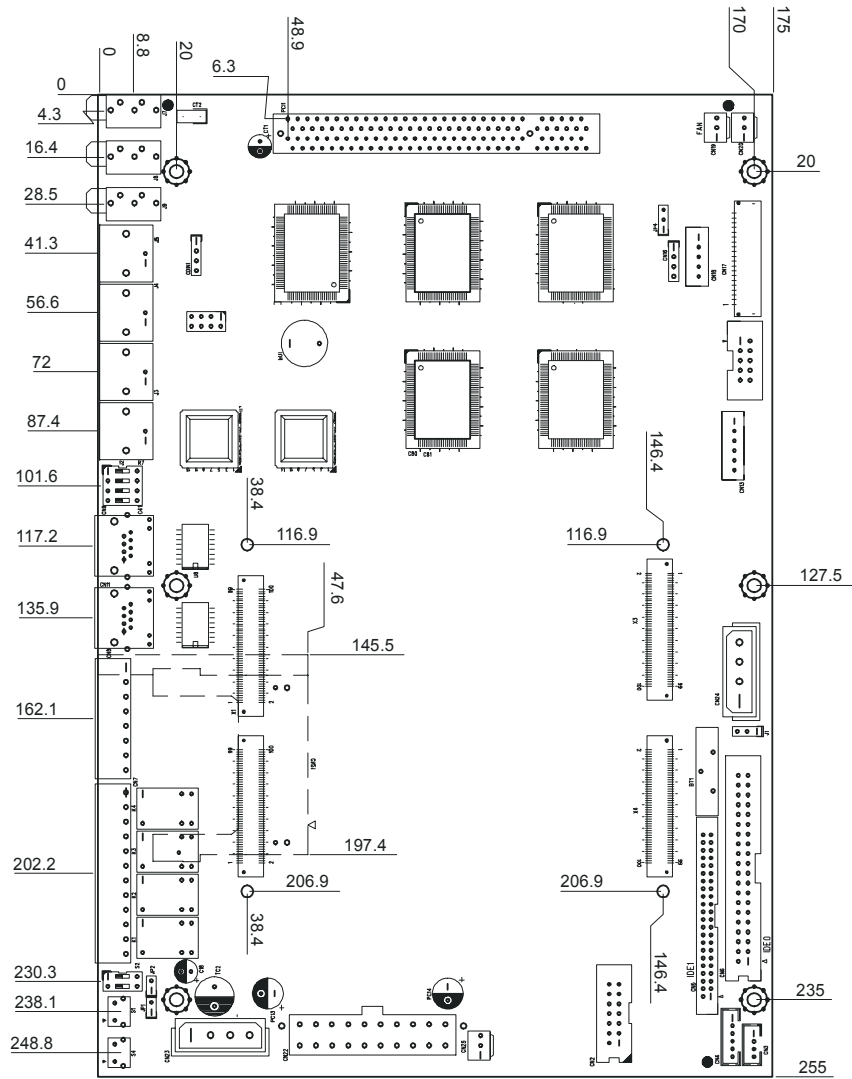

## 2.2 Clear CMOS Setup

To clear the CMOS Setup, close the JP6 (2-3) for about 3 seconds, and then open it again. This will set it back to normal operation mode.

- **JP6: Clear CMOS Setup**



1 2 3

JP6	DESCRIPTION
1-2 (Default)*	Keep CMOS Setup (Normal Operation)
Short 2-3	Clear CMOS Setup

## 2.3 RS232 or RS422/485 Selection

- **S2: RS232 or RS422/485 Selection**

S2	DESCRIPTION
1/ON, 2/OFF	RS232
2/ON, 1/OFF	RS422/485

Caution: If RS422/485 are in use, the COM port on the main board will be disabled.

## 2.4 Video Terminal Resistance Selection

- **S3: 50 Ohm or 75-Ohm Selection**

S3	DESCRIPTION
1, 2, 3, 4/ON	50 Ohm
1, 2, 3, 4/OFF	75 Ohm

## 2.5 LCD Voltage Setting

- JP4: LCD Voltage (5V / 3V) Setting

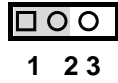

JP4	DESCRIPTION
1 – 2	3V LCD
2 – 3	5V LCD

## 2.6 Compact Flash Card Master/Slave Mode Setting

- JP5: Master/Slave Mode Setting

JP5	DESCRIPTION
OPEN	SLAVE
SHORT	MASTER

### 3. Connection

This chapter describes how to connect peripherals, switches and indicators to the ETX-DB-DVR1 baseboard.

#### 3.1 Audio Connectors

The onboard Audio controller supports several audio functions. The audio connectors are described as below:

##### J7: Left/Right Audio Line Output Connector for Headphone

1.	GROUND
2.	LEFT SIGNAL
3.	NC
4.	RIGHT SIGNAL
5.	NC

##### J8: Left/Right Audio Line Input Connector for Headphone

1.	GROUND
2.	LEFT SIGNAL
3.	GROUND
4.	RIGHT SIGNAL
5.	GROUND

##### J9: Mono Audio MIC Input Connector for Headphone

1.	GROUND
2.	MIC SIGNAL
3.	NC
4.	NC
5.	GROUND

##### CDIN1:

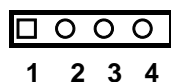

PIN NO.	DESCRIPTION
1.	CD SIGNAL (LEFT)
2.	GROUND
3.	GROUND
4.	CD SIGNAL (RIGHT)

### 3.2 PCI E-IDE Disk Drive Connector

You can attach up to four IDE (Integrated Device Electronics) devices.

**CN6: Primary IDE Connector (40-pin, 2.54 mm)**

**CN5: Secondary IDE Connector (44-pin, 2.0 mm)**

• **CN6 & CN5: IDE Interface Connector**

2 4 6 ... 36 38 40. (44)

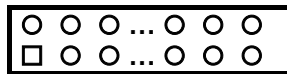

1 3 5 ... 35 37 39. (43)

PIN NO.	DESCRIPTION	PIN NO.	DESCRIPTION
1	RESET#	2	GROUND
3	DATA 7	4	DATA 8
5	DATA 6	6	DATA 9
7	DATA 5	8	DATA 10
9	DATA 4	10	DATA 11
11	DATA 3	12	DATA 12
13	DATA 2	14	DATA 13
15	DATA 1	16	DATA 14
17	DATA 0	18	DATA 15
19	GROUND	20	N/C
21	DRQ	22	GROUND
23	IOW#	24	GROUND
25	IOR#	26	GROUND
27	CHRDY	28	REV. PULL LOW
29	DACK	30	GROUND-DEFAULT
31	INTERRUPT	32	N/C
33	SA1	34	N/C
35	SA0	36	SA2
37	HDC CS0#	38	HDC CS1#
39	HDD ACTIVE#	40	GROUND
41	+5V(IDE2)	42	+5V(IDE2)
43	GND (IDE2)	44	N/C (IDE2)

### 3.3 Compact Flash Storage Card Socket (Optional)

ETX-DB-DVR1 configures Compact Flash Storage Card in IDE Mode. This type II Socket is compatible with IBM Micro Drive.

- **CN21: Compact Flash Storage Card Socket Pin Assignments**

PIN NO.	DESCRIPTION	PIN NO.	DESCRIPTION
1	GROUND	26	CARD DETECT1
2	D3	27	D11
3	D4	28	D12
4	D5	29	D13
5	D6	30	D14
6	D7	31	D15
7	CS1#	32	CS3#
8	N/C	33	N/C
9	GROUND	34	IOR#
10	N/C	35	IOW#
11	N/C	36	OBLIGATORY TO PULL HIGH
12	N/C	37	IRQ15
13	VCC	38	VCC
14	N/C	39	MASTER/SLAVE
15	N/C	40	N/C
16	N/C	41	RESET#
17	N/C	42	IORDY
18	A2	43	N/C
19	A1	44	OBLIGATORY TO PULL HIGH
20	A0	45	ACTIVE#
21	D0	46	PDIAG#
22	D1	47	D8
23	D2	48	D9
24	N/C	49	D10
25	CARD DETECT2	50	GROUND

### 3.4 USB Port Connectors

The ETX-DB-DVR1 is equipped with two USB 1.1 ports for I/O bus expansion.

#### USB1: 2-port USB Connector

PIN NO.	DESCRIPTION	PIN NO.	DESCRIPTION
1.	VCC	2.	GROUND
3.	DATA0-	4.	DATA1+
5.	DATA0+	6.	DATA1-
7.	GROUND	8.	VCC

### 3.5 ATX Power Connector and Switch

The ETX-DB-DVR1 can work with external power through this ATX power connector.

#### • CN22: ATX Power Supply Connector

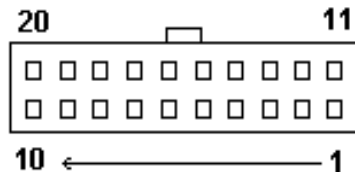

CN22 is a 20-pin ATX Power Supply Connector. Please refer to the following table for the pin assignments.

PIN NO.	DESCRIPTION	PIN NO.	DESCRIPTION
11	3.3V	1	3.3V
12	-12V	2	3.3V
13	GND	3	GND
14	PSON#	4	+5V
15	GND	5	GND
16	GND	6	+5V
17	GND	7	GND
18	-5V	8	Power good
19	+5V	9	+5VSB
20	+5V	10	+12V

- **S1, CN27: ATX Power Switch Connector**

**S1: Switch**

**CN27: Pin Header**

<b>PIN NO.</b>	<b>DESCRIPTION</b>
1	PWR_BUTTON+
2	PWR_BUTTON-

- **S4, CN26: Power RESET Switch Connector**

**S4: Switch**

**CN26: Pin Header**

<b>PIN NO.</b>	<b>DESCRIPTION</b>
1	RESET+
2	RESET-

- **JP3: ATX Power PSON# Connector**

<b>PIN NO.</b>	<b>DESCRIPTION</b>
1	PSON#
2	GND

### 3.6 Serial Ports

ETX-DB-DVR1 offers two high speed NS16C550 compatible UART's with 16-byte Read/Receive FIFO serial ports.

- **CN2: Serial Port 2x7 Pin Header Connector (COM1)**

COM1 supports three modes: RS232, RS422/RS485  
(For 2x7 Pin Header Connector)

#### RS232 Mode

PIN NO.	DESCRIPTION	PIN NO.	DESCRIPTION
1	DCD	2	DSR
3	RXD	4	RTS
5	TXD	6	CTX
7	DTR	8	RI
9	GND	10	
11		12	
13		14	

#### RS422 / RS485 Mode (For 2x7 Pin Header Connector)

##### RS422 Mode

PIN NO.	DESCRIPTION	PIN NO.	DESCRIPTION
1		2	
3		4	
5		6	
7		8	
9		10	
11	TX+	12	TX-
13	RX+	14	RX-

##### RS485 Mode (For 2x7 Pin Header Connector)

PIN NO.	DESCRIPTION	PIN NO.	DESCRIPTION
1		2	
3		4	
5		6	
7		8	
9		10	
11		12	
13	RX+	14	RX-

- **CN3: Serial Port 4 Pin JST (2.0 mm) Connector (COM2)**

**COM2: RS232**

PIN NO.	DESCRIPTION
1	VCC5
2	TXD
3	RXD
4	GND

### **3.7 Keyboard/Mouse Connector**

ETX-DB-DVR1 has a 6-pin keyboard/mouse connector.

- **CN13: 6-pin Keyboard/Mouse Connector**

PIN NO.	DESCRIPTION
1	VCC
2	MOUSE DATA
3	MOUSE CLK
4	KEYBOARD DATA
5	KEYBOARD CLK
6	GND

### **3.8 LAN, HDD, Power Status LED Connector**

ETX-DB-DVR1 has a LED connector to show LAN, HDD and POWER status.

- **CN4: JST (2.0 mm) LED Connector**

PIN NO.	DESCRIPTION
1	LAN-LED+
2	LAN-LED-
3	HDD-LED+
4	HDD-LED-
5	POWER-LED+
6	POWER-LED-

### 3.9 Fan Connector

ETX-DB-DVR1 supports three cooling fan connector, which can supply 12V/500mA to the cooling fan.

- **CN19, CN20, CN25: Fan Connector**

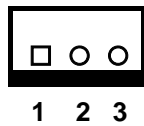

PIN NO.	DESCRIPTION
1	NC
2	+12V
3	GND

### 3.10 VGA Connector

- **CN14: 10-pin Header Connector**

1	RED	2	DDCCLK
3	GREEN	4	DDC DAT
5	BLUE	6	GROUND
7	HSYNC	8	GROUND
9	VSYNC	10	GROUND

### 3.11AT & IDE Power Connector

ETX-DB-DVR1 is equipped with one standard power connector and one IDE power connector.

- **CN23: 4-pin AT Power Connector**

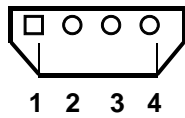

PIN NO.	DESCRIPTION
1	+12V
2	GND
3	GND
4	+5V

- **CN24: 4-pin IDE Power Connector**

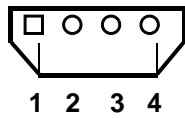

PIN NO.	DESCRIPTION
1	+12V
2	GND
3	GND
4	+5V

### 3.12 LAN RJ45 Connector

ETX-DB-DVR1 is equipped with two 10/100Mbps Ethernet controllers. You can connect it to your LAN through RJ45 LAN connector. The pin assignments are as follows:

- **CN9, CN11: LAN RJ45 Connector**

PIN NO.	DESCRIPTION	PIN NO.	DESCRIPTION
1	TX+	5.	N/C
2	TX-	6.	RX-
3.	RX+	7.	N/C
4.	N/C	8.	N/C

### 3.13 TV Out Connector

- **CN16: TV Connector**

PIN NO.	DESCRIPTION	PIN NO.	DESCRIPTION
1	TV-CVBS	2	TV-Y
3	TV-C	4	GND

### 3.14 Video Capture Connector

- **J5, J4, J3, J2: Video Capture Connector**

**J5: Video 0**

**J4: Video 1**

**J3: Video 2**

**J2: Video 3**

PIN NO.	DESCRIPTION
1	GND
2	Video

### 3.15 TFT LCD & Inverter Connector

ETX-DB-DVR1 is equipped with TFT LCD (20-pin Hirose) connector, which is connected to the LCD via CN17 connector. The ETX CPU module has to provide 36-bit LVDS interface. The pin assignments are as follows:

- **CN17: TFT LCD Connector**

PIN NO.	DESCRIPTION
1	B-CLK+
2	B-CLK-
3	B-D2+
4	B-D2-
5	B-D1+
6	B-D1-
7	B-D0+
8	B-D0-
9	A-CLK+
10	A-CLK-
11	A-D2+
12	A-D2-
13	A-D1+
14	A-D1-
15	A-D0+
16	A-D0-
17	GND
18	GND
19	LCD_VCC
20	LCD_VCC

- **CN18: LCD Inverter Connector**

PIN NO.	DESCRIPTION
1	NC
2	GND
3	+12V
4	GND
5	FPEN

### 3.16 Input / Output Device Connector

ETX-DB-DVR1 is an 8-output and 4-input device.

An input connector and an output connector are provided for connections to the external devices. The connection points of the input connector are shown in Figure 1.

The connection points of the output connector are shown in Figure 2.

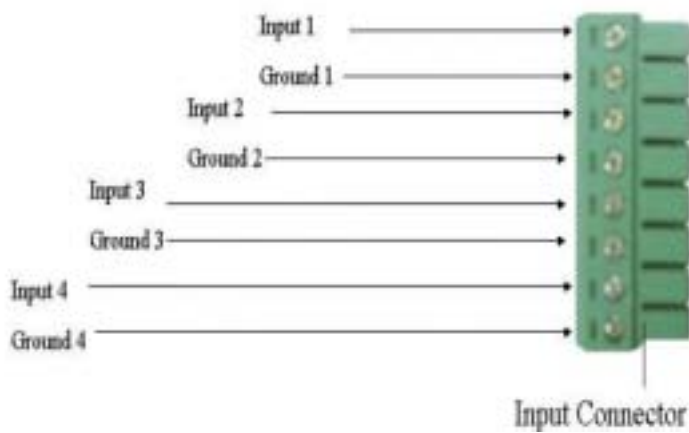

Figure 1

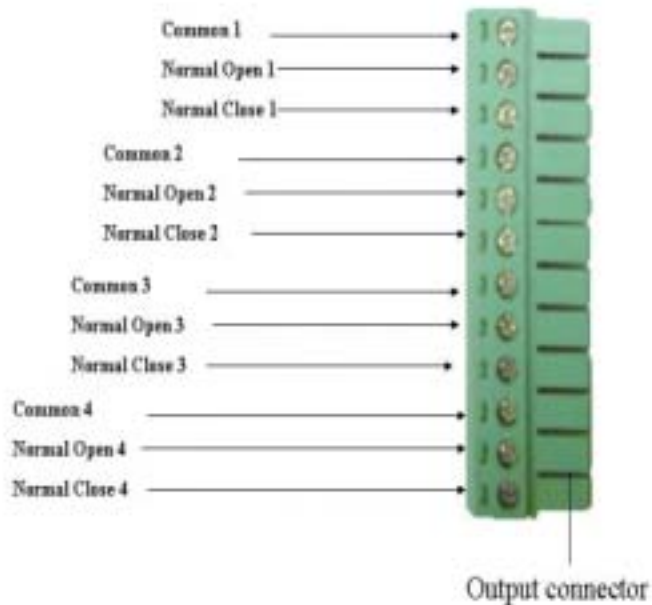

Figure 2

### Specification for General Inputs

#### Input 5VDC

Function	DESCRIPTION
Logic 0	0.5 Max
Logic 1	4.5 Min

#### Input 12VDC

Function	DESCRIPTION
Logic 0	0.5 Max
Logic 1	11 Min

### Specification for General Output Relay Contact Ratings

Contact Form	1 FORM C (SPDT)
Contact Capacity	Coil = 0.36W
Resistive Load	1A/125 VAC
(Cos $\theta$ = 1)	2A/24 VDC
Inductive Load	0.3A/30 VDC
(Cos $\theta$ = 0.4 L/R = 7 msec)	
Rated Carrying Current	2A
Max allowable voltage	AC 120V. DC 60V
Max allowable current	2A
Max allowable power	48W
Contact Material	Ag Alloy

### Relay Coil Specification

Coil voltage	Nominal Voltage (VDC)	Nominal Current (mA)	Coil Resistance (Ohm)	Power Consumption (W)
5V	5V	66.7	75	About 0.36W

### Relay Coil Specification

Pull-in Voltage (VDC)	Drop-out voltage (VDC)	Max-Allowable Voltage (VDC)
75% max. 3.75V	10% min. 0.5V	110% 5.5V

### 3.17 ETX Board X1-X4 Connector

ETX-DB-DVR1 Baseboard has four connectors (X1-X4), which are connected to CPU module.

- X1 Connector: PCI Bus, USB and Audio

PIN	SIGNAL	PIN	SIGNAL
1	GND	2	GND
3	PCICLK3	4	PCICLK4
5	GND	6	GND
7	PCICLK1	8	PCICLK2
9	REQ3#	10	GNT3#
11	GNT2#	12	3V
13	REQ2#	14	GNT1#
15	REQ1#	16	3V
17	GNT0#	18	RESERVED
19	VCC	20	VCC
21	SERIRQ	22	REQ0#
23	AD0	24	3V
25	AD1	26	AD2
27	AD4	28	AD3
29	AD6	30	AD5
31	CBE0#	32	AD7
33	AD8	34	AD9
35	GND	36	GND
37	AD10	38	AUXAL
39	AD11	40	MIC
41	AD12	42	AUXAR
43	AD13	44	ASVCC
45	AD14	46	SNDL
47	AD15	48	ASGND
49	CBE1#	50	SNDR

PIN	SIGNAL	PIN	SIGNAL
51	VCC	52	VCC
53	PAR	54	SERR#
55	GPERR#	56	RESERVED
57	PME#	58	USB2
59	LOCK#	60	DEVSEL#
61	TRDY#	62	USB3
63	IRDY#	64	STOP#
65	FRAME#	66	USB2#
67	GND	68	GND
69	AD16	70	CBE2#
71	AD17	72	USB3#
73	AD19	74	AD18
75	AD20	76	USB0
77	AD22	78	AD21
79	AD23	80	USB1
81	AD24	82	CBE3#
83	VCC	84	VCC
85	AD25	86	AD26
87	AD28	88	USB0#
89	AD27	90	AD29
91	AD30	92	USB1#
93	PCIRST#	94	AD31
95	INTC#	96	INTD#
97	INTA#	98	INTB#
99	GND	100	GND

• X2 Connector: ISA Bus

PIN	SIGNAL	PIN	SIGNAL
1	GND	2	GND
3	SD14	4	SD15
5	SD13	6	N.C.
7	SD12	8	DRQ7
9	SD11	10	DACK7#
11	SD10	12	DRQ6
13	SD9	14	DACK6#
15	SD8	16	DRQ5
17	MEMW#	18	DACK5#
19	MEMR#	20	DRQ0
21	SA17	22	DACK0#
23	SA18	24	IRQ14
25	SA19	26	IIQR15
27	SA20	28	IRQ12
29	SA21	30	IRQ11
31	SA22	32	IRQ10
33	SA23	34	IOCS16#
35	GND	36	GND
37	SBHE#	38	MEMCS16#
39	SA0	40	OSC
41	SA1	42	BALE
43	SA1	44	TC
45	SA3	46	DACK2#
47	SA4	48	IRQ3
49	SA5	50	IRQ4

PIN	SIGNAL	PIN	SIGNAL
51	5V	52	5V
53	SA6	54	IRQ5
55	SA7	56	IRQ6
57	SA8	58	IRQ7
59	SA9	60	SYSCLK
61	SA10	62	N.C.
63	SA11	64	REQ1
65	SA12	66	DACK1#
67	GND	68	GND
69	SA13	70	DRQ3
71	SA14	72	DACK3#
73	SA15	74	IOR#
75	SA16	76	IOW#
77	SA18	78	SA17
79	SA19	80	SMEMR#
81	IOCHR DY	82	AEN
83	5V	84	5V
85	SD0	86	SMEMW#
87	SD2	88	SD1
89	SD3	90	ZOWS#
91	DRQ2	92	SD4
93	SD5	94	IRQ9
95	SD6	96	SD7
97	N.C.	98	RSTDRV
99	GND	100	GND

• X3 Connector: VGA, LCD, Video, COM1, COM2, LPT/Floppy, Irda, Mouse and Keyboard

PIN	SIGNAL	PIN	SIGNAL
1	GND	2	GND
3	R	4	B
5	HSY	6	G
7	VSY	8	DDCK
9	DETECT#	10	DDDA
11	LCDDO16	12	RESERVED
13	LCDDO17	14	RESERVED
15	GND	16	GND
17	LCDDO13	18	LCDDO15
19	LCDDO12	20	LCDDO14
21	GND	22	GND
23	RESERVED	24	LCDDO11
25	RESERVED	26	LCDDO10
27	GND	28	GND
29	LCDDO4	30	LCDDO7
31	LCDDO5	32	LCDDO6
33	GND	34	GND
35	LCDDO1	36	LCDDO3
37	LCDDO0	38	LCDDO2
39	VCC	40	VCC
41	JILI_DAT	42	LTGIO0
43	JILI_CLK	44	BLON#
45	BIASON	46	DIGON
47	COMP	48	Y
49	SYNC	50	C

PIN	SIGNAL	PIN	SIGNAL
51	LPT/FLPY#	52	RESERVED
53	VCC	54	GND
55	STB# / RESERVED	56	AFD# / DENSEL
57	RESERVED	58	PD7 / RESERVED
59	IRRX	60	ERR# / HDSEL#
61	IRTX	62	PD6 / RESERVED
63	RXD2	64	INIT# / DR#
65	GND	66	GND
67	RTS2#	68	PD5 / RESERVED
69	DTR2#	70	SLIN# / STEP#
71	DCD2#	72	PD4 / DSKCHG#
73	DSR2#	74	PD3 / RDATA#
75	CTD2#	76	PD2 / WP#
77	TXD2	78	PD1 / TRK0#
79	RI2#	80	PD0 / INDEX#
81	VCC	82	VCC
83	RXD1	84	ACK# / DRV
85	RTS1#	86	BUSY# / MOT
87	DTR1#	88	PE / WDATA#
89	DCD1#	90	SLCT# / WGATE#
91	DSR1#	92	MSCLK
93	CTS1#	94	MSDAT
95	TXD1	96	KBCLK
97	RI1#	98	KBDAT
99	GND	100	GND

• X4 Connector: IDE1, IDE2 and Miscellaneous

PIN	SIGNAL	PIN	SIGNAL	PIN	SIGNAL	PIN	SIGNAL
1	GND	2	GND	51	SIDE_IOW#	52	PIDE_IOR#
3	5V_SB	4	PWGIN	53	SIDE_DRQ	54	PIDE_IOW#
5	PS_ON	6	SPEAKER	55	SIDE_D15	56	PIDE_DRQ
7	PWRBTN#	8	BATT	57	SIDE_D0	58	PIDE_D15
9	RESERVED	10	RESERVED	59	SIDE_D14	60	PIDE_D0
11	RESERVED	12	RESERVED	61	SIDE_D1	62	PIDE_D14
13	RESERVED	14	RESERVED	63	SIDE_D13	64	PIDE_D1
15	RESERVED	16	RESERVED	65	GND	66	GND
17	VCC	18	VCC	67	SIDE_D2	68	PIDE_D13
19	RESERVED	20	RESERVED	69	SIDE_D12	70	PIDE_D2
21	RESERVED	22	RESERVED	71	SIDE_D3	72	PIDE_D12
23	SMBCLK	24	SMBDATA	73	SIDE_D11	74	PIDE_D3
25	SIDE_CS3#	26	RESERVED	75	SIDE_D4	76	PIDE_11
27	SIDE_CS1#	28	DASP_S	77	SIDE_D10	78	PIDE_D4
29	SIDE_A2	30	PIDE_CS3	79	SIDE_D5	80	PIDE_D10
31	SIDE_A0	32	PIDE_CS1#	81	VCC	82	VCC
33	GND	34	GND	83	SIDE_D9	84	PIDE_D5
35	PDIAG_S	36	PIDE_A2	85	SIDE_D6	86	PIDE_D9
37	SIDE_A1	38	PIDE_A0	87	SIDE_D8	88	PIDE_D6
39	SIDE_INTRQ	40	PIDE_A1	89	RESERVED	90	RESERVED
41	RESERVED	42	RESERVED	91	RXD#	92	PIDE_D8
43	SIDE_AK#	44	PIDE_INTRQ	93	RXD	94	SIDE_D7
45	SIDE_RDY	46	PIDE_AK#	95	TXD#	96	PIDE_D7
47	SIDE_IOR#	48	PIDE_RDY	97	TXD	98	HDRST#
49	VCC	50	VCC	99	GND	100	GND