



IEI Technology Corp.



MODEL:
AFL-W19A/W19B/17D/W15A-N270

**Panel PC with Touch Screen Intel® CPU
Gigabit Ethernet, USB, Audio, RS-232/422/485, SATA
RoHS Compliant, IP 64 Protection**

User Manual

Rev. 1.02 – 26 May, 2009



Revision

Date	Version	Changes
26 May, 2009	1.02	Minor updates
8 April, 2009	1.01	Added 15"
18 March, 2009	1.00	Initial release

Copyright

COPYRIGHT NOTICE

The information in this document is subject to change without prior notice in order to improve reliability, design and function and does not represent a commitment on the part of the manufacturer.

In no event will the manufacturer be liable for direct, indirect, special, incidental, or consequential damages arising out of the use or inability to use the product or documentation, even if advised of the possibility of such damages.

This document contains proprietary information protected by copyright. All rights are reserved. No part of this manual may be reproduced by any mechanical, electronic, or other means in any form without prior written permission of the manufacturer.

TRADEMARKS

All registered trademarks and product names mentioned herein are used for identification purposes only and may be trademarks and/or registered trademarks of their respective owners.

Table of Contents

1 INTRODUCTION.....	1
1.1 OVERVIEW.....	2
1.2 MODEL VARIATIONS	2
1.3 FEATURES.....	3
1.4 EXTERNAL OVERVIEW.....	3
1.4.1 <i>Front Panel</i>	3
1.4.2 <i>Rear Panel</i>	4
1.4.3 <i>Bottom Panel</i>	5
1.5 INTERNAL OVERVIEW.....	5
1.6 SPECIFICATIONS	5
1.7 DIMENSIONS.....	7
1.7.1 <i>AFL-W15A-N270 Dimensions</i>	7
1.7.2 <i>AFL-17D-N270 Dimensions</i>	8
1.7.3 <i>AFL-W19A-N270 Dimensions</i>	9
1.7.4 <i>AFL-W19B-N270 Dimensions</i>	10
2 INSTALLATION	11
2.1 UNPACK THE PANEL PC.....	12
2.2 PACKING LIST.....	13
2.3 HARD DRIVE INSTALLATION.....	14
2.4 COMPACTFLASH® INSTALLATION	17
2.5 JUMPER SETTINGS	18
2.5.1 <i>COM1 Pin-9 Setup</i>	18
2.5.2 <i>COM3 Pin-9 Setup</i>	19
2.5.3 <i>COM3 RS-232/422/485 Setup</i>	20
2.6 MOUNTING THE SYSTEM	21
2.7 BOTTOM PANEL CONNECTORS	21
2.7.1 <i>LAN Connection</i>	22
2.7.2 <i>Serial Device Connection</i>	23
2.7.3 <i>USB Device Connection</i>	23
2.7.4 <i>VGA Monitor Connection</i>	24

AFL-W19A/W19B/17D/W15A-N270 Panel PC

2.8 POWER CONNECTION	25
2.9 DRIVER INSTALLATION.....	25
3 BIOS SETUP	27
3.1 INTRODUCTION.....	28
3.1.1 Starting Setup.....	28
3.1.2 Using Setup	28
3.1.3 Getting Help.....	29
3.1.4 Unable to Reboot After Configuration Changes.....	29
3.1.5 BIOS Menu Bar.....	29
3.2 MAIN.....	30
3.3 ADVANCED.....	31
3.3.1 CPU Configuration.....	32
3.3.2 IDE Configuration	33
3.3.2.1 IDE Master, IDE Slave	34
3.3.3 Super IO Configuration	39
3.3.4 Hardware Health Configuration.....	42
3.3.5 Power Configuration	45
3.3.5.1 ACPI Settings.....	46
3.3.5.2 APM Configuration.....	47
3.3.6 Remote Access Configuration	49
3.3.7 USB Configuration.....	53
3.3.7.1 USB Mass Storage Device Configuration.....	55
3.4 PCI/PNP.....	56
3.5 BOOT.....	59
3.5.1 Boot Settings Configuration.....	59
3.5.2 Boot Device Priority	62
3.5.3 Hard Disk Drives	63
3.5.4 Removable Drives	63
3.5.5 CD/DVD Drives.....	64
3.6 SECURITY.....	65
3.7 CHIPSET	66
3.7.1 Northbridge Configuration	67
3.7.2 Southbridge Configuration	69
3.8 EXIT.....	70

4 SYSTEM MAINTENANCE	72
4.1 SYSTEM MAINTENANCE INTRODUCTION	73
4.2 MOTHERBOARD REPLACEMENT	73
4.3 COVER REMOVAL	73
4.4 MEMORY MODULE REPLACEMENT	74
A SAFETY PRECAUTIONS	76
A.1 SAFETY PRECAUTIONS	77
<i>A.1.1 General Safety Precautions</i>	<i>77</i>
<i>A.1.2 Anti-static Precautions</i>	<i>78</i>
A.2 MAINTENANCE AND CLEANING PRECAUTIONS	78
<i>A.2.1 Maintenance and Cleaning</i>	<i>79</i>
<i>A.2.2 Cleaning Tools</i>	<i>79</i>
B BIOS OPTIONS	80
C TERMINOLOGY	84
D WATCHDOG TIMER	88
E HAZARDOUS MATERIALS DISCLOSURE	91
E.1 HAZARDOUS MATERIALS DISCLOSURE TABLE FOR IPB PRODUCTS CERTIFIED AS ROHS COMPLIANT UNDER 2002/95/EC WITHOUT MERCURY	92

List of Figures

Figure 1-1: AFL-W19A/W19B/17D/W15A-N270	2
Figure 1-2: Front Panel	4
Figure 1-3: Rear Panel.....	4
Figure 1-4: Bottom Panel	5
Figure 1-5: AFL-W15A-N270 Dimensions	7
Figure 1-6: AFL-17D-N270 Dimensions	8
Figure 1-7: AFL-W19A-N270 Dimensions	9
Figure 1-8: AFL-W19B-N270 Dimensions	10
Figure 2-1: Aluminum Back Cover Retention Screws	15
Figure 2-2: HDD Bracket Retention Screws.....	15
Figure 2-3: HDD Retention Screws	16
Figure 2-4: HDD Installation.....	16
Figure 2-5: Remove CompactFlash [®] Cover.....	17
Figure 2-6: CompactFlash [®] Install.....	18
Figure 2-7: Connectors	22
Figure 2-8: LAN Connection	22
Figure 2-9: Serial Device Connector.....	23
Figure 2-10: USB Device Connection	24
Figure 2-11: VGA Connector	25
Figure 4-1: Back Cover Retention Screws	74
Figure 4-2: DDR SO-DIMM Module Installation.....	75

List of Tables

Table 1-1: System Specifications.....	6
Table 2-1: Packing List.....	14
Table 2-2: COM1 Pin-9 Setup.....	19
Table 2-3: COM1 Pinouts	19
Table 2-4: COM3 Pin-9 Setup.....	20
Table 2-5: COM3 RS-232/422/485 Setup	20
Table 2-6: COM3 RS-232/422/485 Setup	20
Table 2-7: COM3 Pinouts	21
Table 3-1: BIOS Navigation Keys	29

BIOS Menus

BIOS Menu 1: Main	30
BIOS Menu 2: Advanced	31
BIOS Menu 3: CPU Configuration	32
BIOS Menu 4: IDE Configuration	33
BIOS Menu 5: IDE Master and IDE Slave Configuration	34
BIOS Menu 6: Super IO Configuration.....	39
BIOS Menu 7: Hardware Health Configuration	42
BIOS Menu 8: APM Configuration.....	45
BIOS Menu 9: ACPI Settings	46
BIOS Menu 10: APM Configuration.....	47
BIOS Menu 11: Remote Access Configuration.....	49
BIOS Menu 12: USB Configuration	53
BIOS Menu 13: USB Mass Storage Device Configuration	55
BIOS Menu 14: PCI/PnP Configuration.....	57
BIOS Menu 15: Boot	59
BIOS Menu 16: Boot Settings Configuration	59
BIOS Menu 17: Boot Device Priority Settings	62
BIOS Menu 18: Hard Disk Drives	63
BIOS Menu 19: Removable Drives	63
BIOS Menu 20: CD/DVD Drives	64
BIOS Menu 21: Security	65
BIOS Menu 22: Chipset	66
BIOS Menu 23:Northbridge Chipset Configuration.....	67
BIOS Menu 24:Southbridge Chipset Configuration	69
BIOS Menu 25:Exit.....	70

Chapter

1

Introduction

1.1 Overview



Figure 1-1: AFL-W19A/W19B/17D/W15A-N270

The Afolux panel PCs are all-in-one panel PCs with all the elements of a desktop computer contained in a single, slim package, no bigger than a thick monitor. The Afolux panel PCs can be mounted on a desktop monitor stand and save a huge amount of desktop space by including all the computer components behind the screen. All models include a touch screen interface.

The Afolux is a self-contained system, with all parts, excluding the power supply, contained inside the casing allowing a completely interactive panel PC with only a single power cable. External devices are connected wirelessly through Bluetooth technology and network access is enabled through a 802.11b/g/n wireless adapter. Wired options are always available on the rear panel, with two serial ports and four USB ports for peripherals and two Gigabit Ethernet slots for networking.

The Afolux includes both audio and visual multimedia capabilities. All models have a VGA output for connecting another monitor to the system, and audio outputs for external audio. There is also a built-in 300 K webcam and a microphone input jack.

1.2 Model Variations

The AFL-17D-N270 and AFL-W19B-N270 also support a built-in slim-type SATA optical disk drive.

AFL-W19A/W19B/17D/W15A-N270 Panel PC

1.3 Features

Some of the standard features of the AFL-W19A/W19B/17D/W15A-N270 flat panel PC include:

- Fully self-contained, only power from the external power supply required
- Touch screen
- Wireless LAN
- Gigabit Ethernet
- Bluetooth
- IP64 protection
- RoHS compliant

1.4 External Overview

The AFL-W19A/W19B/17D/W15A-N270 consists of a screen and rear panel that covers the back, sides and top. The rear panel contains a smaller access panel, all the cable connections and the mounting holes.

1.4.1 Front Panel

The front side of the AFL-W19A/W19B/17D/W15A-N270 is a flat panel LCD screen surrounded by a plastic frame.

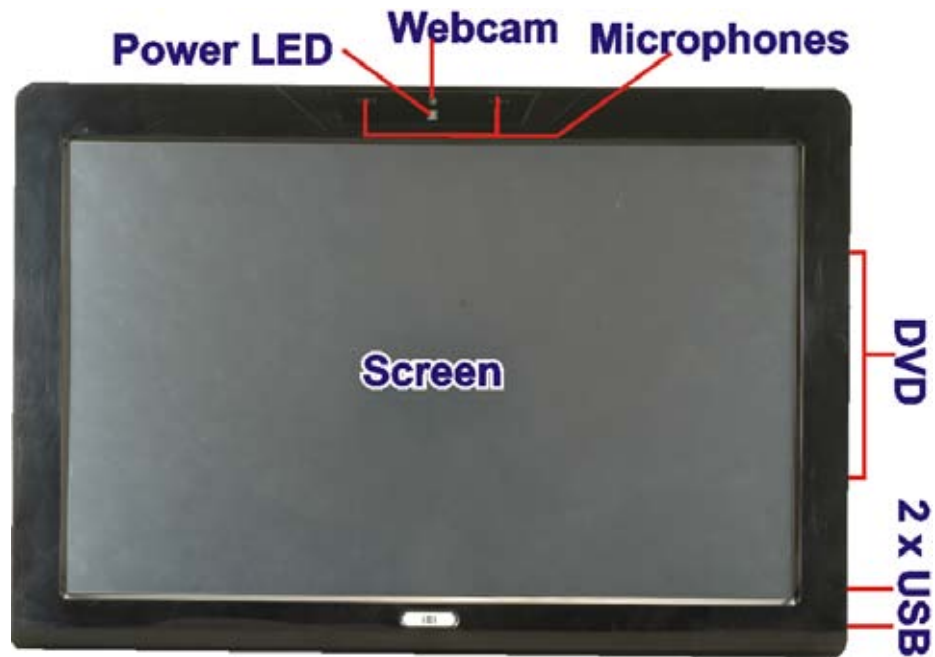

Figure 1-2: Front Panel

1.4.2 Rear Panel

The rear panel provides access to retention screw holes that support the wall mounting. Refer to Figure 1-3.



Figure 1-3: Rear Panel

AFL-W19A/W19B/17D/W15A-N270 Panel PC

1.4.3 Bottom Panel

The bottom panel has the following slots, buttons and switches (Figure 1-4):

- 2 x Gigabit LAN
- 1 x Line output (audio)
- 1 x OSD keypad
- 1 x Power switch
- 1 x Power input (12 V)
- 1 x Reset button
- 1 x RS-232
- 1 x RS-232/422/485
- 4 x USB ports
- 1 x VGA port

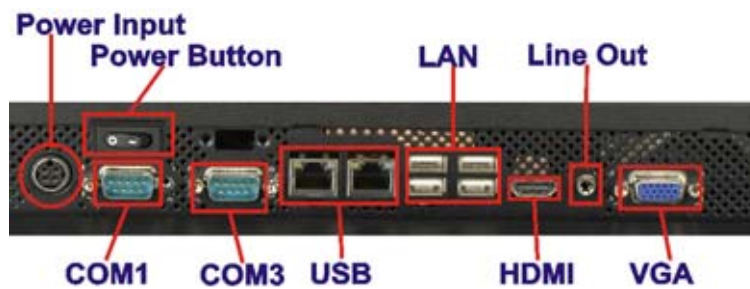

Figure 1-4: Bottom Panel

1.5 Internal Overview

All the components are contained under the rear panel. The internal components include the touch panel module and the motherboard. The motherboard has memory, a wireless module and a hard drive. Optionally, an HSDPA module can be installed in any of the models. The AFL-W19B-N270 also supports an optical disk drive.

1.6 Specifications

The technical specifications for the AFL-W19A/W19B/17D/W15A-N270 systems are listed in Table 1-1.

SPECIFICATION	AFL-W15A-N270	AFL-17D-N270	AFL-W19A-N270	AFL-W19B-N270
Mainboard	AFLMB2-945GSE-N270			

SPECIFICATION	AFL-W15A-N270	AFL-17D-N270	AFL-W19A-N270	AFL-W19B-N270
CPU	1.6GHz Intel® Atom			
LCD Panel	15.6"	17"	19"	19"
Resolution	1366 x 768	1280 x 1024	1440 x 900	1440 x 900
Brightness	250	300	300	300
Contrast Ratio	500:1	800:1	850:1	850:1
LCD Colors	16.2 million	16.7 million	16.2 million	16.2 million
Pixel Pitch	0.252 x 0.252	0.264 x 0.264	0.285 x 0.285	0.285 x 0.285
Viewing Angle (H/V)	170/130	160/160	160/160	160/160
Backlight MTBF	50000	50000	50000	50000
Touch Screen	5-wire resistive touch panel			
IP Level	IP 64 front panel			
I/O	2 x Gigabit LAN 1 x Line output (audio) 1 x Power input (12 V) 1 x RS-232 1 x RS-232/422/485 4 x USB ports 1 x VGA port			
Power Adapter	100-240 VAC input, 12 V output			
Power Consumption				
Mounting Feature	VESA 100x100			
Operating Temp.	0°C ~ 40°C			
Dimension (WxHxD)	400 x 273 x 62.9	410 x 349 x 83	475 x 332 x 65	475 x 332 x 84
Net/Gross Weight	3.3 kg	6.2 kg	5.8 kg	6.2 kg
Front Panel Protection	IP 64 compliant			
EMC and Safety	CE, FCC, CB, CCC			

Table 1-1: System Specifications

AFL-W19A/W19B/17D/W15A-N270 Panel PC

1.7 Dimensions

1.7.1 AFL-W15A-N270 Dimensions

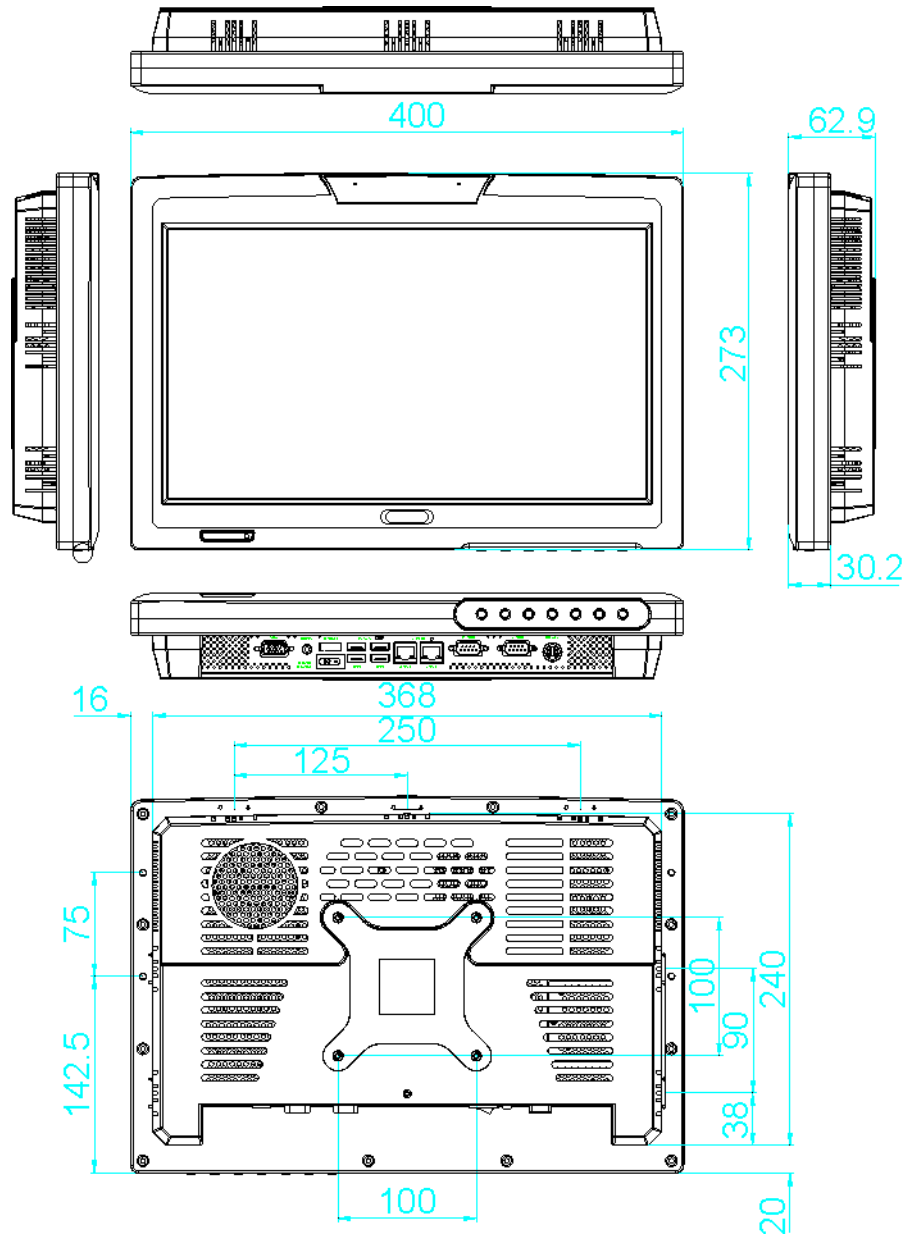

Figure 1-5: AFL-W15A-N270 Dimensions

1.7.2 AFL-17D-N270 Dimensions

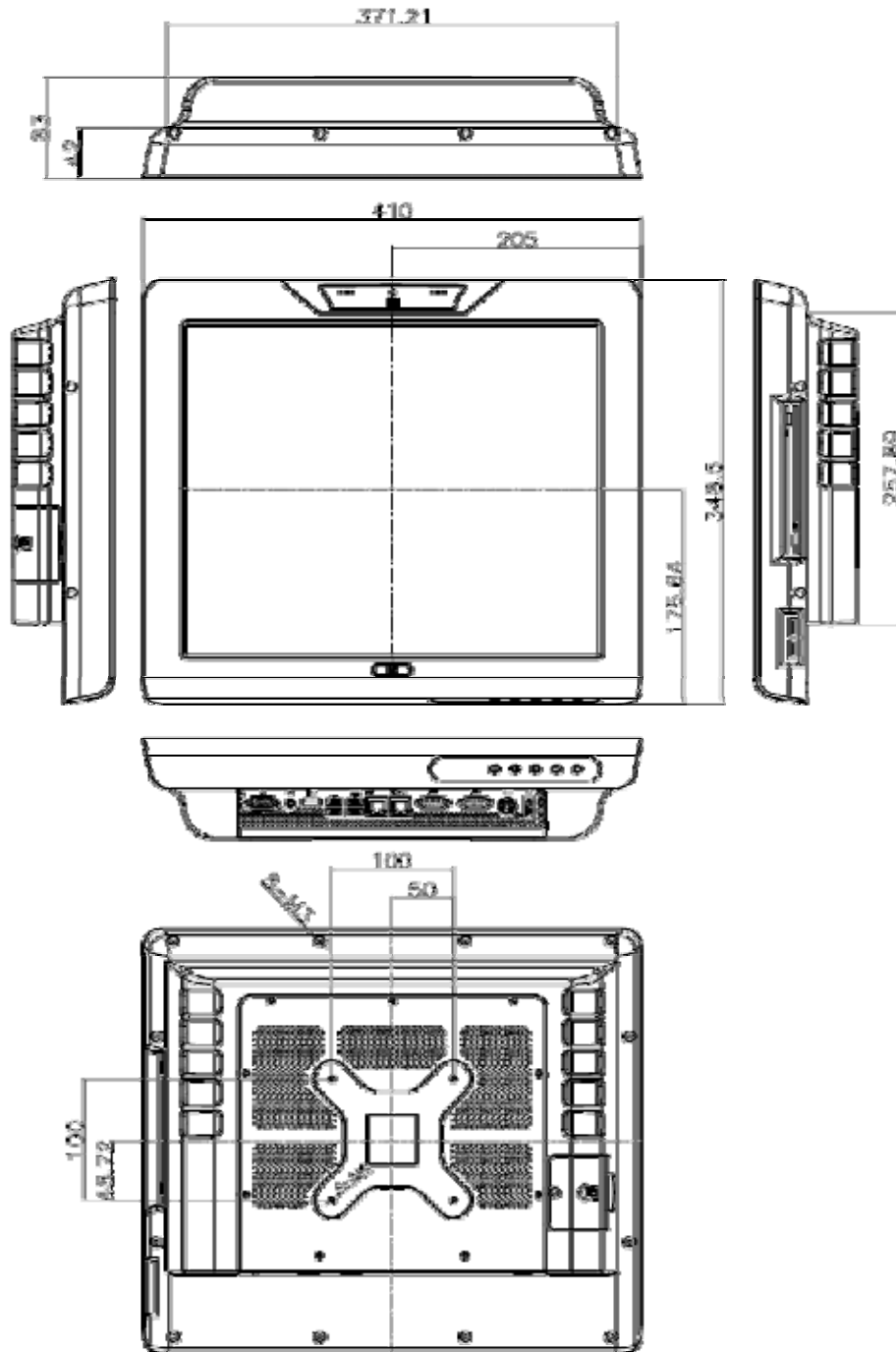

Figure 1-6: AFL-17D-N270 Dimensions

AFL-W19A/W19B/17D/W15A-N270 Panel PC

1.7.3 AFL-W19A-N270 Dimensions

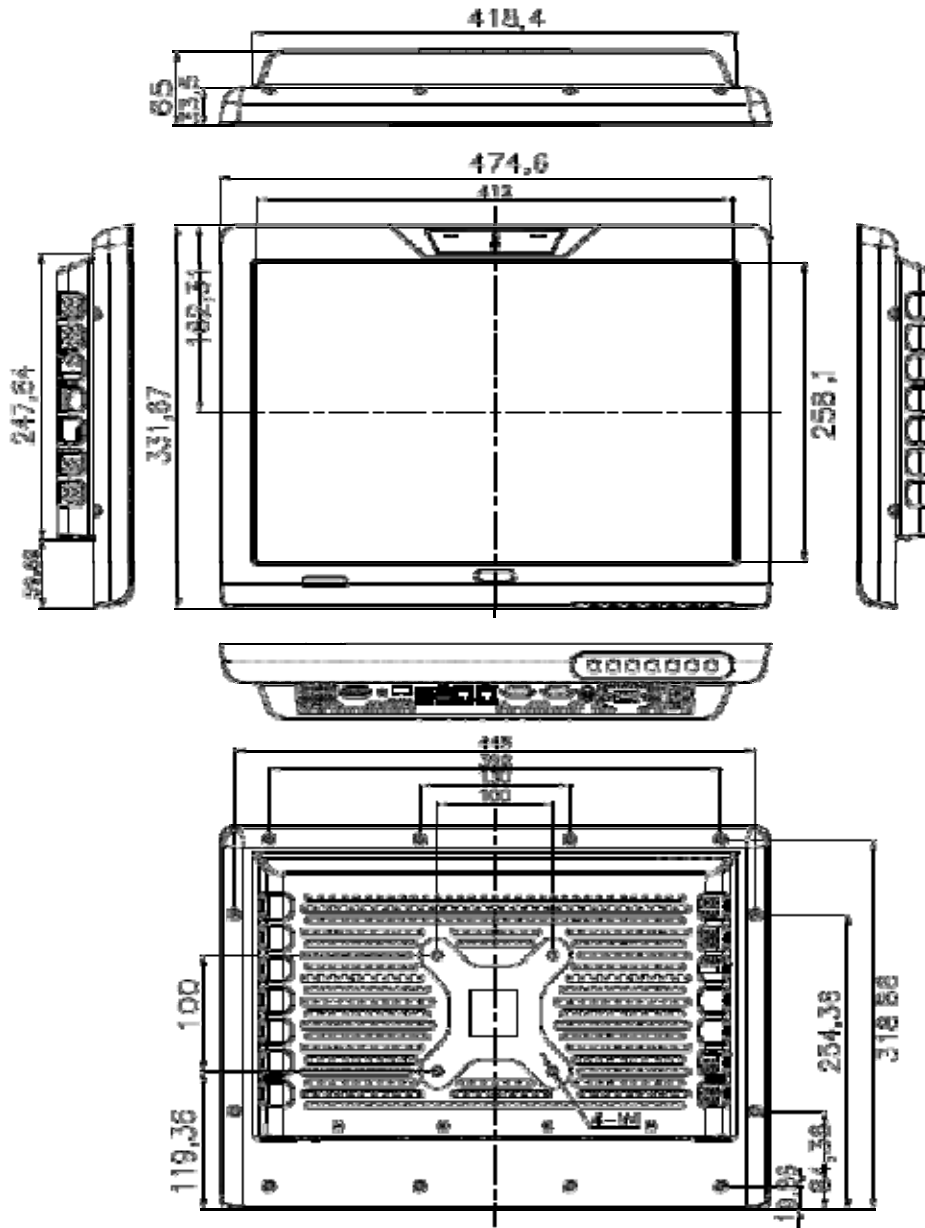

Figure 1-7: AFL-W19A-N270 Dimensions

1.7.4 AFL-W19B-N270 Dimensions

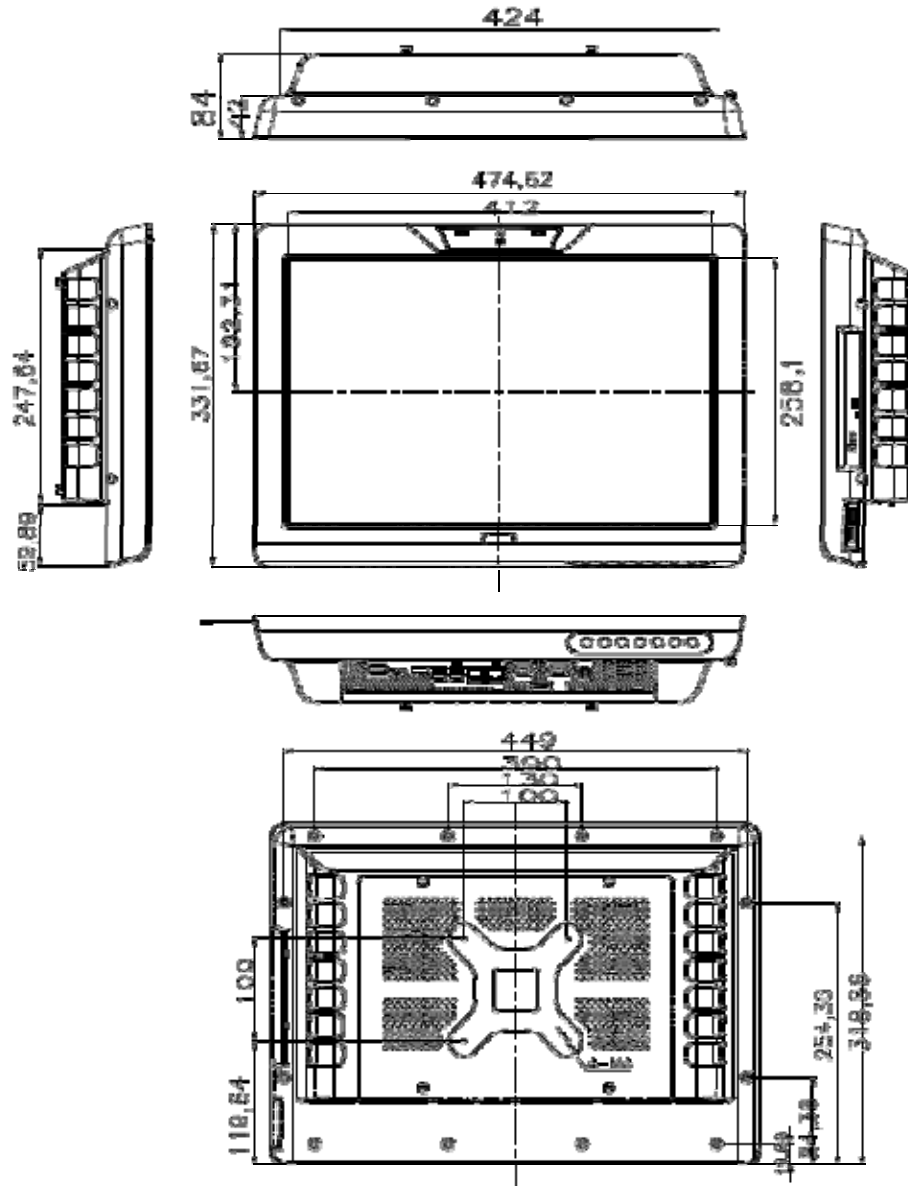

Figure 1-8: AFL-W19B-N270 Dimensions

Chapter

2

Installation

**WARNING:**

When installing the AFL-W19A/W19B/17D/W15A-N270, make sure to:

- **Turn the power off:** Chance of electrocution. Turn off the monitor and unplug it from the power supply.
- **Only let certified engineers change the hardware settings:** Incorrect settings can cause irreparable damage to the product.
- **Install the monitor with assistance:** The product is very heavy and may be damaged by drops and bumps. Two or more people should install the panel PC.
- **Take anti-static precautions:** Electrostatic discharge can destroy electrical components and injure the user. Users must ground themselves using an anti-static wristband or similar device.

The installation steps below should be followed in order.

Step 1: Unpack the flat panel PC

Step 2: Check all the required parts are included

Step 3: Install the hard drive

Step 4: Install the CompactFlash® card

Step 5: Mount the flat panel PC

Step 6: Connect peripheral devices to the bottom panel of the flat panel PC

Step 7: Connect the power cable

Step 8: Configure the system

2.1 Unpack the Panel PC

To unpack the flat panel PC, follow the steps below:

AFL-W19A/W19B/17D/W15A-N270 Panel PC



WARNING!

Only remove the protective plastic cover stuck to the front screen after installation. The plastic layer protects the monitor surface during installation process.

Step 1: Carefully cut the tape sealing the box. Only cut deep enough to break the tape.

Step 2: Open the outside box.

Step 3: Carefully cut the tape sealing the box. Only cut deep enough to break the tape.

Step 4: Open the inside box.

Step 5: Lift the monitor out of the boxes.

Step 6: Remove the peripheral parts box from the main box.

2.2 Packing List

The AFL-W19A/W19B/17D/W15A-N270 flat panel PC is shipped with the following components:

Quantity	Item	Image
1	AFL-W19A/W19B/17D/W15A-N270	
1	Power adapter	
1	Power cord	
1	Screw set	



Quantity	Item	Image
1	Touch screen pen	
1	Utility CD	

Table 2-1: Packing List

If any of these items are missing or damaged, contact the distributor or sales representative immediately.

2.3 Hard Drive Installation

This section outlines the installation of the hard drive in the AFL-W19A/W19B/17D/W15A-N270. To install the hard drive, please follow the steps below:

Step 1: Remove the plastic back cover.

Step 2: Unfasten the four silver retention screws. The screws will not separate from the cover, just loosen as much as possible (Figure 2-1).

AFL-W19A/W19B/17D/W15A-N270 Panel PC



Figure 2-1: Aluminum Back Cover Retention Screws

Step 3: Slide the cover down, then lift to remove.

Step 4: Remove the four HDD bracket retention screws (Figure 2-2) and lift the HDD brackets out of the panel PC.



Figure 2-2: HDD Bracket Retention Screws

Step 5: Attach the HDD brackets to the HDD. The brackets are different for each side. Make sure the side with the hard drive screw hole further from the end goes at the SATA connector end as shown in Figure 2-3.



Figure 2-3: HDD Retention Screws

Step 6: Install the hard drive in the same position it was before.

Step 7: Slide down from the top to connect the motherboard SATA connector to the hard drive SATA connector.



Figure 2-4: HDD Installation

Step 8: Fasten the screws.

AFL-W19A/W19B/17D/W15A-N270 Panel PC

Step 9: A CompactFlash® card can also be installed in the CompactFlash® slot shown in Figure 2-4 above.

2.4 CompactFlash® Installation

The installation for the AFL-17D-N270 is shown in this section. The CompactFlash® card installation for the AFL-W19A-N270 and AFL-W19B-N270 is shown in the hard drive installation section above.

Step 10: Undo the CompactFlash® slot screw.

Step 11: Slide the cover upwards to remove.



Figure 2-5: Remove CompactFlash® Cover

Step 12: Install the CompactFlash® in the slot inside.

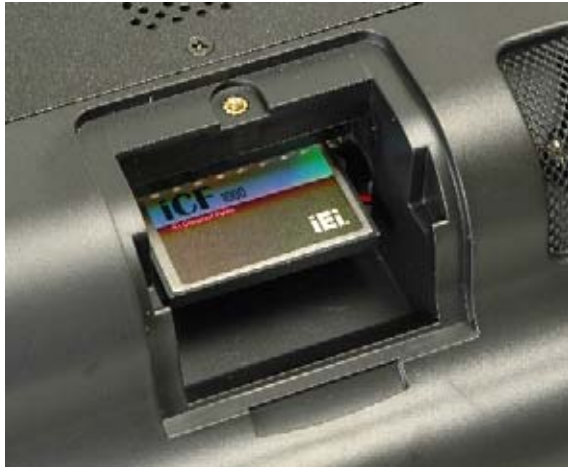

Figure 2–6: CompactFlash® Install

Step 13: Slide the cover back on, then fasten the screw.

2.5 Jumper Settings



NOTE:

A jumper is a metal bridge that is used to close an electrical circuit. It consists of two metal pins and a small metal clip (often protected by a plastic cover) that slides over the pins to connect them. To CLOSE/SHORT a jumper means connecting the pins of the jumper with the plastic clip and to OPEN a jumper means removing the plastic clip from a jumper.

The motherboard jumpers are listed below.

- COM1 pin 9 setup
- COM3 pin 9 setup
- COM3 RS-232/422/485 selection

2.5.1 COM1 Pin-9 Setup

Jumper Label: JP11
Jumper Type: 10-pin header

AFL-W19A/W19B/17D/W15A-N270 Panel PC

Jumper Settings: See Table 2-2

The pin-9 signal can be selected as 12 V, 5 V or Ring.

Pin	Description
1-3	12 V
3-5	5 V
7-9	RI

Table 2-2: COM1 Pin-9 Setup

The pinouts for the connector are shown below.

Pin	Description
1	DCD
2	RX
3	TX
4	DTR
5	GND
6	DSR
7	RTS
8	CTS
9	RI

Table 2-3: COM1 Pinouts

2.5.2 COM3 Pin-9 Setup

Jumper Label: J5

Jumper Type: 10-pin header

Jumper Settings: See Table 2-4

The pin-9 signal can be selected as 12 V, 5 V or Ring.

Pin	Description
1-2	12 V
3-4	RI

Pin	Description
5-6	5 V

Table 2-4: COM3 Pin-9 Setup

2.5.3 COM3 RS-232/422/485 Setup

- Jumper Label:** J3 and J4
- Jumper Type:** 8-pin and 12-pin headers
- Jumper Settings:** See Table 2-5 and Table 2-6

This serial port can be set to use RS-232, RS-422 or RS-485 communication methods. Set all the jumpers to the same settings.

J3	Description
1-2	According to BIOS settings
3-4	RS-232
5-6	RS-422
7-8	RS-485

Table 2-5: COM3 RS-232/422/485 Setup

J4	Description
1-2, 4-5, 7-8, 10-11	RS-232
2-3, 5-6, 8-9, 11-12	RS-422/485

Table 2-6: COM3 RS-232/422/485 Setup

The pinouts for RS-232, RS-422 and RS-485 communication are shown below.

Pin	RS-232 Desc.	RS-422 Desc.	RS-485 Desc.
1	DCD	TX-	D-
2	RX	TX+	D+
3	TX		
4	DTR		
5	GND		
6	DSR	RX-	

AFL-W19A/W19B/17D/W15A-N270 Panel PC

Pin	RS-232 Desc.	RS-422 Desc.	RS-485 Desc.
7	RTS	RX+	
8	CTS		
9	RI		

Table 2-7: COM3 Pinouts

2.6 Mounting the System



WARNING!

The panel PC is very heavy. Two or more people should mount the panel PC. Dropping or bumping the panel PC during installation can cause serious or irreparable damage to the panel PC.

The following installation options are available:

- Lift stand
- Wall arm
- Wall mount
- Ceiling mount
- Mobile mount

The installation instructions are included with the stand, arm or mount.

2.7 Bottom Panel Connectors

The bottom panel connectors extend the capabilities of the panel PC but are not essential for operation (except power).

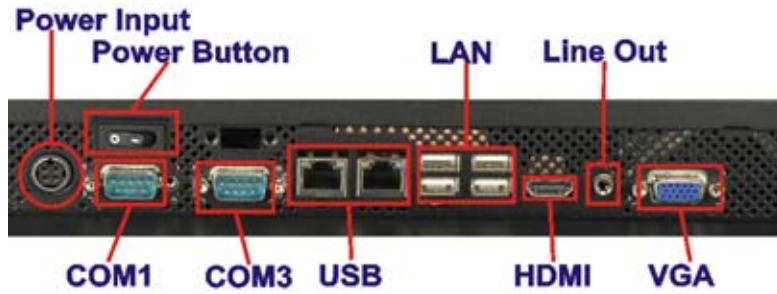

Figure 2-7: Connectors

2.7.1 LAN Connection

The RJ-45 connectors enable connection to an external network. To connect a LAN cable with an RJ-45 connector, please follow the instructions below.

Step 1: Locate the RJ-45 connector on the bottom panel of the AFL-W19A/W19B/17D/W15A-N270.

Step 2: Align the connectors. Align the RJ-45 connector on the LAN cable with one of the RJ-45 connectors on the bottom panel of the AFL-W19A/W19B/17D/W15A-N270. See Figure 2-8..

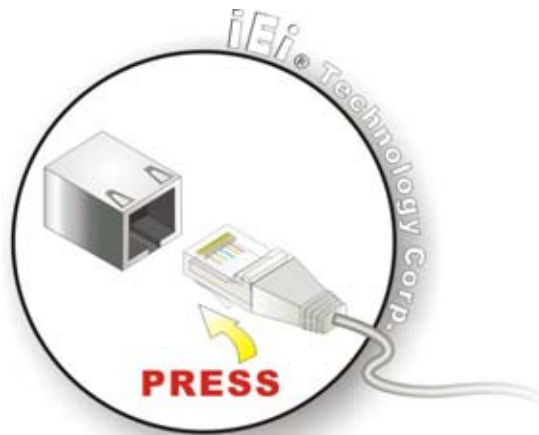

Figure 2-8: LAN Connection

Step 3: Insert the LAN cable RJ-45 connector. Once aligned, gently insert the LAN cable RJ-45 connector into the onboard RJ-45 port.

AFL-W19A/W19B/17D/W15A-N270 Panel PC

2.7.2 Serial Device Connection

The serial device connectors are for connecting serial devices to the AFL-W19A/W19B/17D/W15A-N270. Follow the steps below to connect a serial device to the AFL-W19A/W19B/17D/W15A-N270 panel PC.

Step 1: **Locate the DB-9 connector.** The location of the DB-9 connector is shown in **Chapter 2**.

Step 2: **Insert the serial connector.** Insert the DB-9 connector of a serial device into the DB-9 connector on the bottom panel. See Figure 2-9.

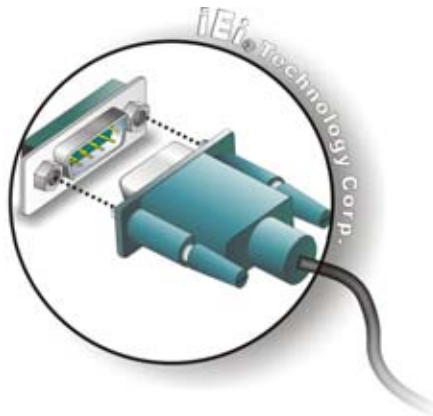

Figure 2-9: Serial Device Connector

Step 3: **Secure the connector.** Secure the serial device connector to the external interface by tightening the two retention screws on either side of the connector.

2.7.3 USB Device Connection

To connect USB devices to the AFL-W19A/W19B/17D/W15A-N270, please follow the instructions below.

Step 1: **Located the USB connectors.** The locations of the USB connectors are shown in **Chapter 2**.

Step 2: **Align the connectors.** Align the USB device connector with one of the connectors on the bottom panel. See Figure 2-10.

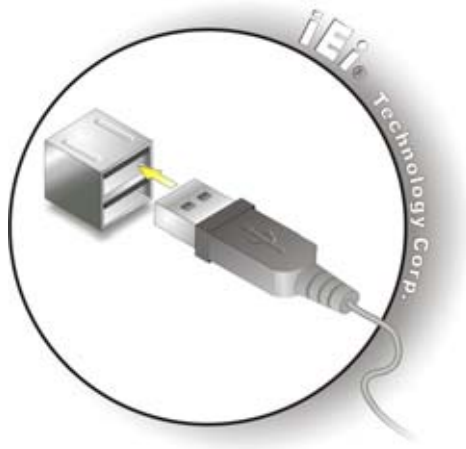

Figure 2-10: USB Device Connection

Step 3: **Insert the device connector.** Once aligned, gently insert the USB device connector into the onboard connector.

2.7.4 VGA Monitor Connection

The VGA output can be connected to an external VGA monitor. To connect the VGA monitor to the AFL-W19A/W19B/17D/W15A-N270, please follow the instructions below.

Step 1: **Locate the female DB-15 connector.** The location of the female DB-15 connector is shown in **Chapter 3**.

Step 2: **Align the VGA connector.** Align the male DB-15 connector on the VGA screen cable with the female DB-15 connector on the external peripheral interface.

Step 3: **Insert the VGA connector** Once the connectors are properly aligned with the insert the male connector from the VGA screen into the female connector on the AFL-W19A/W19B/17D/W15A-N270. See Figure 2-11.

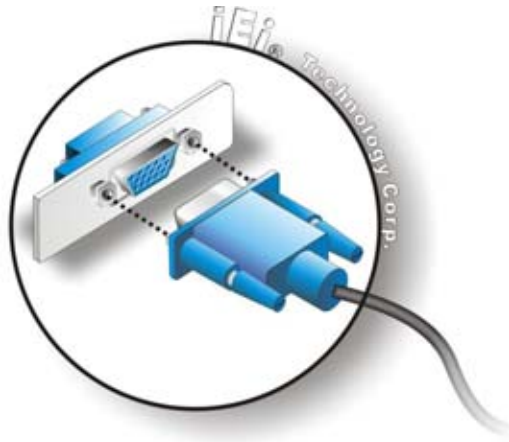

Figure 2-11: VGA Connector

Step 4: **Secure the connector.** Secure the DB-15 VGA connector from the VGA monitor to the external interface by tightening the two retention screws on either side of the connector.

2.8 Power Connection

The power cable connects the panel PC to the power supply. The power cable is required for operation of the panel PC.

Step 1: Connect one end to the panel PC.

Step 2: Connect the other end to the included power supply

2.9 Driver Installation



NOTE:

The content of the CD may vary throughout the life cycle of the product and is subject to change without prior notice. Visit the IEI website or contact technical support for the latest updates.

The following drivers can be installed on the system, each driver is in its own directory on the driver CD:

- Chipset driver
- Graphics driver
- LAN driver
- Audio driver
- Touch panel driver
- Keypad utility driver
- Wireless LAN card driver
- Bluetooth driver

Chapter

3

BIOS Setup

3.1 Introduction

The BIOS is programmed onto the BIOS chip. The BIOS setup program allows changes to certain system settings. This chapter outlines the options that can be changed.

3.1.1 Starting Setup

The AMI BIOS is activated when the computer is turned on. The setup program can be activated in one of two ways.

1. Press the **DELETE** key as soon as the system is turned on or
2. Press the **DELETE** key when the “**Press Del to enter SETUP**” message appears on the screen.

If the message disappears before the **DELETE** key is pressed, restart the computer and try again.

3.1.2 Using Setup

Use the arrow keys to highlight items, press **ENTER** to select, use the PageUp and PageDown keys to change entries, press **F1** for help and press **Esc** to quit. Navigation keys are shown in.

Key	Function
Up arrow	Move to previous item
Down arrow	Move to next item
Left arrow	Move to the item on the left hand side
Right arrow	Move to the item on the right hand side
Esc key	Main Menu – Quit and not save changes into CMOS Status Page Setup Menu and Option Page Setup Menu -- Exit current page and return to Main Menu
Page Up key	Increase the numeric value or make changes
Page Dn key	Decrease the numeric value or make changes
F1 key	General help, only for Status Page Setup Menu and Option Page Setup Menu

AFL-W19A/W19B/17D/W15A-N270 Panel PC

Key	Function
F2 /F3 key	Change color from total 16 colors. F2 to select color forward.
F10 key	Save all the CMOS changes, only for Main Menu

Table 3-1: BIOS Navigation Keys

3.1.3 Getting Help

When **F1** is pressed a small help window describing the appropriate keys to use and the possible selections for the highlighted item appears. To exit the Help Window press **Esc** or the **F1** key again.

3.1.4 Unable to Reboot After Configuration Changes

If the computer cannot boot after changes to the system configuration is made, CMOS defaults. Use the jumper described in Chapter 5.

3.1.5 BIOS Menu Bar

The **menu bar** on top of the BIOS screen has the following main items:

- Main – Changes the basic system configuration.
- Advanced – Changes the advanced system settings.
- PCIPnP – Changes the advanced PCI/PnP Settings
- Boot – Changes the system boot configuration.
- Security – Sets User and Supervisor Passwords.
- Chipset – Changes the chipset settings.
- Exit – Selects exit options and loads default settings

The following sections completely describe the configuration options found in the menu items at the top of the BIOS screen and listed above.

3.2 Main

The **Main** BIOS menu (BIOS Menu 1) appears when the **BIOS Setup** program is entered. The **Main** menu gives an overview of the basic system information.

```

BIOS SETUP UTILITY
Main  Advanced  PCIPNP  Boot  Security  Chipset  Power  Exit
-----
System Overview
-----
AMIBIOS
Version      :08.00.15
Build Date   :12/08/08
ID:          :H436MR11

Processor
Genuine Intel® CPU N270 @ 1.60 GHz
Speed        :1600 MHz
Count        :1

System Memory
Size         :1016MB

System Time           [14:20:27]
System Time           [Tue 03/17/2009]

Use [ENTER], [TAB] or [SHIFT-TAB] to select a field.

Use [+] or [-] to configure system time.

←→ Select Screen
↑↓ Select Item
Enter Go to SubScreen
F1  General Help
F10 Save and Exit
ESC Exit

v02.61 ©Copyright 1985-2006, American Megatrends, Inc.

```

BIOS Menu 1: Main

- **System Overview**

The **System Overview** lists a brief summary of different system components. The fields in **System Overview** cannot be changed. The items shown in the system overview include:

- AMI BIOS: Displays auto-detected BIOS information
 - **Version:** Current BIOS version
 - **Build Date:** Date the current BIOS version was made
 - **ID:** Installed BIOS ID
- Processor: Displays auto-detected CPU specifications
 - **Type:** Names the currently installed processor
 - **Speed:** Lists the processor speed
 - **Count:** The number of CPUs on the motherboard
- System Memory: Displays the auto-detected system memory.
 - **Size:** Lists memory size

AFL-W19A/W19B/17D/W15A-N270 Panel PC

The System Overview field also has two user configurable fields:

- **System Time [xx:xx:xx]**

Use the **System Time** option to set the system time. Manually enter the hours, minutes and seconds.

- **System Date [xx/xx/xx]**

Use the **System Date** option to set the system date. Manually enter the day, month and year.

3.3 Advanced

Use the **Advanced** menu (BIOS Menu 2) to configure the CPU and peripheral devices

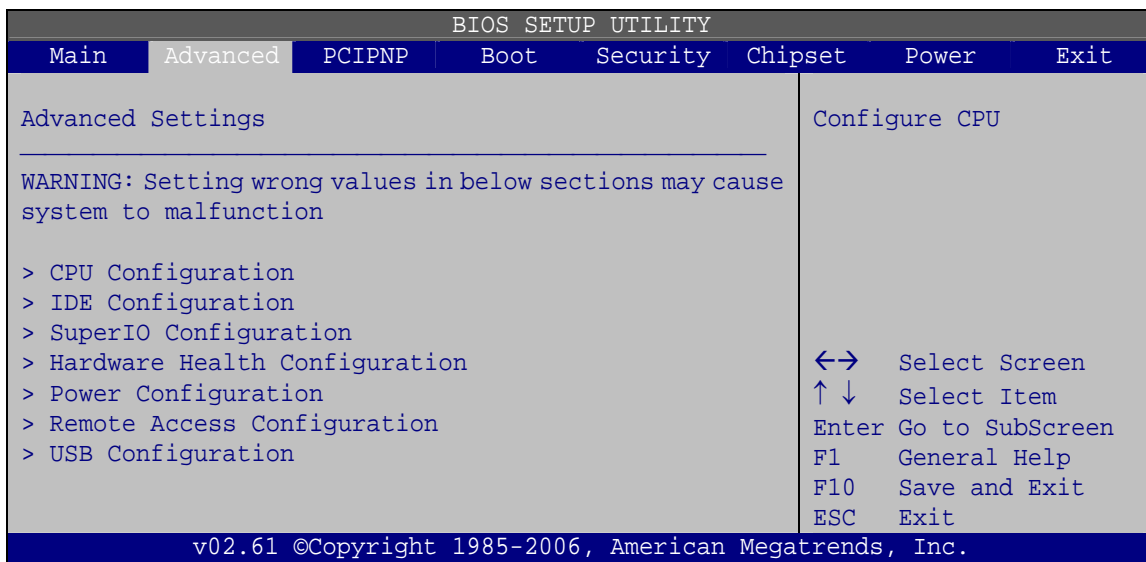

BIOS Menu 2: Advanced

3.3.1 CPU Configuration

Use the **CPU Configuration** menu (BIOS Menu 3) to view detailed CPU specifications and configure the CPU.

```

BIOS SETUP UTILITY
Main  Advanced  PCIPNP  Boot  Security  Chipset  Power  Exit
-----
Configure Advanced CPU Settings
Module Version:3F.12
-----
Manufacturer   :Intel@
Genuine Intel@ CPU N270 @ 1.60 GHz
Frequency      :1.60GHz
FSB Speed      :532MHz
Cache L1       : 24KB
Cache L2       : 512KB
Ratio Actual Value:12

<=> Select Screen
↑↓ Select Item
Enter Go to SubScreen
F1 General Help
F10 Save and Exit
ESC Exit

v02.61 ©Copyright 1985-2006, American Megatrends, Inc.
    
```

BIOS Menu 3: CPU Configuration

The CPU Configuration menu lists the following CPU details:

- Manufacturer: Lists the name of the CPU manufacturer
- Brand String: Lists the brand name of the CPU being used
- Frequency: Lists the CPU processing speed
- FSB Speed: Lists the FSB speed
- Cache L1: Lists the CPU L1 cache size
- Cache L2: Lists the CPU L2 cache size

AFL-W19A/W19B/17D/W15A-N270 Panel PC

3.3.2 IDE Configuration

Use the **IDE Configuration** menu (BIOS Menu 4) to change and/or set the configuration of the IDE devices installed in the system.

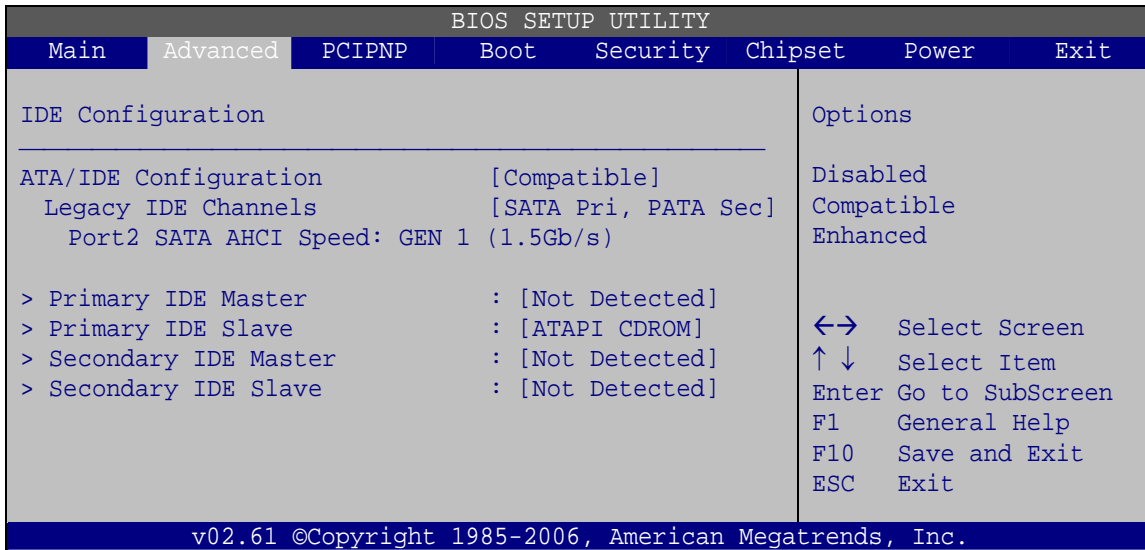

BIOS Menu 4: IDE Configuration

- **ATA/IDE Configuration [Compatible]**

Use the **ATA/IDE Configuration** option to configure the ATA/IDE controller.

- ➔ **Disabled** Disables the on-board ATA/IDE controller.
- ➔ **Compatible** **DEFAULT** The SATA drive is configured on an IDE channel.
- ➔ **Enhanced** Both IDE and SATA channels are configured separately.

- **Legacy IDE Channels [SATA Pri, PATA Sec]**

Use the **Legacy IDE Channels** option to configure SATA devices as normal IDE devices.

- ➔ **SATA Only** Only SATA drives are on the IDE channels. IDE drives are disabled
- ➔ **SATA Pri, PATA Sec** **DEFAULT** SATA drives are configured on the Primary IDE channel. IDE drives on the Secondary IDE channel

➔ **PATA Only** Only the IDE drives are enabled. SATA drives are disabled

- **Configure SATA as [IDE]**

Use the **Configure SATA as** option to configure SATA devices as normal IDE devices.

➔ **IDE DEFAULT** Configures SATA devices as normal IDE device.

➔ **RAID** Used when a RAID setup is installed

➔ **AHCI** Enables advanced SATA drive features

3.3.2.1 IDE Master, IDE Slave

Use the **IDE Master** and **IDE Slave** configuration menu to view both primary and secondary IDE device details and configure the IDE devices connected to the system.

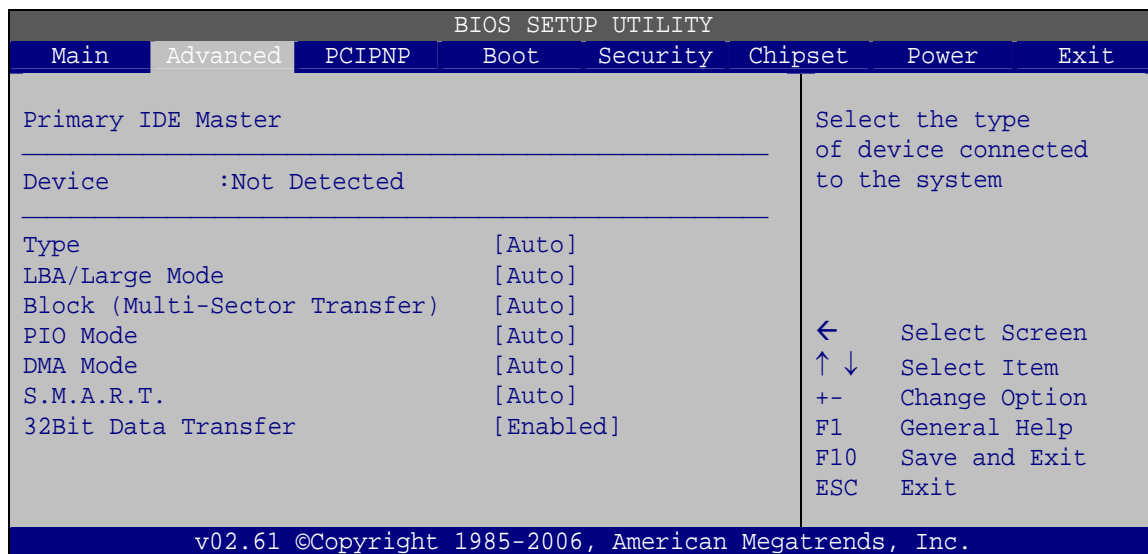

BIOS Menu 5: IDE Master and IDE Slave Configuration

- **Auto-Detected Drive Parameters**

The “grayed-out” items in the left frame are IDE disk drive parameters automatically detected from the firmware of the selected IDE disk drive. The drive parameters are listed as follows:

- **Device:** Lists the device type (e.g. hard disk, CD-ROM etc.)

AFL-W19A/W19B/17D/W15A-N270 Panel PC

- **Type:** Indicates the type of devices a user can manually select
- **Vendor:** Lists the device manufacturer
- **Size:** List the storage capacity of the device.
- **LBA Mode:** Indicates whether the LBA (Logical Block Addressing) is a method of addressing data on a disk drive is supported or not.
- **Block Mode:** Block mode boosts IDE drive performance by increasing the amount of data transferred. Only 512 bytes of data can be transferred per interrupt if block mode is not used. Block mode allows transfers of up to 64 KB per interrupt.
- **PIO Mode:** Indicates the PIO mode of the installed device.
- **Async DMA:** Indicates the highest Asynchronous DMA Mode that is supported.
- **Ultra DMA:** Indicates the highest Synchronous DMA Mode that is supported.
- **S.M.A.R.T.:** Indicates whether or not the Self-Monitoring Analysis and Reporting Technology protocol is supported.
- **32Bit Data Transfer:** Enables 32-bit data transfer.

- **Type [Auto]**

Use the **Type** BIOS option select the type of device the AMIBIOS attempts to boot from after the Power-On Self-Test (POST) is complete.

- ➔ **Not Installed** BIOS is prevented from searching for an IDE disk drive on the specified channel.
- ➔ **Auto** **DEFAULT** The BIOS auto detects the IDE disk drive type attached to the specified channel. This setting should be used if an IDE hard disk drive is attached to the specified channel.
- ➔ **CD/DVD** The CD/DVD option specifies that an IDE CD-ROM drive is attached to the specified IDE channel. The BIOS does not attempt to search for other types of IDE disk drives on the specified channel.

- ➔ **ARMD** This option specifies an ATAPI Removable Media Device. These include, but are not limited to:
 - ZIP
 - LS-120

- **LBA/Large Mode [Auto]**

Use the **LBA/Large Mode** option to disable or enable BIOS to auto detects LBA (Logical Block Addressing). LBA is a method of addressing data on a disk drive. In LBA mode, the maximum drive capacity is 137 GB.

- ➔ **Disabled** BIOS is prevented from using the LBA mode control on the specified channel.
- ➔ **Auto** **DEFAULT** BIOS auto detects the LBA mode control on the specified channel.

- **Block (Multi Sector Transfer) [Auto]**

Use the **Block (Multi Sector Transfer)** to disable or enable BIOS to auto detect if the device supports multi-sector transfers.

- ➔ **Disabled** BIOS is prevented from using Multi-Sector Transfer on the specified channel. The data to and from the device occurs one sector at a time.
- ➔ **Auto** **DEFAULT** BIOS auto detects Multi-Sector Transfer support on the drive on the specified channel. If supported the data transfer to and from the device occurs multiple sectors at a time.

- **PIO Mode [Auto]**

Use the **PIO Mode** option to select the IDE PIO (Programmable I/O) mode program timing cycles between the IDE drive and the programmable IDE controller. As the PIO mode increases, the cycle time decreases.

AFL-W19A/W19B/17D/W15A-N270 Panel PC

- **Auto** **DEFAULT** BIOS auto detects the PIO mode. Use this value if the IDE disk drive support cannot be determined.
- **0** PIO mode 0 selected with a maximum transfer rate of 3.3 MB/s
- **1** PIO mode 1 selected with a maximum transfer rate of 5.2 MB/s
- **2** PIO mode 2 selected with a maximum transfer rate of 8.3 MB/s
- **3** PIO mode 3 selected with a maximum transfer rate of 11.1 MB/s
- **4** PIO mode 4 selected with a maximum transfer rate of 16.6 MB/s
(This setting generally works with all hard disk drives manufactured after 1999. For other disk drives, such as IDE CD-ROM drives, check the specifications of the drive.)

▪ **DMA Mode [Auto]**

Use the **DMA Mode** BIOS selection to adjust the DMA mode options.

- **Auto** **DEFAULT** BIOS auto detects the DMA mode. Use this value if the IDE disk drive support cannot be determined.
- **SWDMA0** Single Word DMA mode 0 selected with a maximum data transfer rate of 2.1 MB/s
- **SWDMA1** Single Word DMA mode 1 selected with a maximum data transfer rate of 4.2 MB/s
- **SWDMA2** Single Word DMA mode 2 selected with a maximum data transfer rate of 8.3 MB/s
- **MWDMA0** Multi Word DMA mode 0 selected with a maximum data transfer rate of 4.2 MB/s
- **MWDMA1** Multi Word DMA mode 1 selected with a maximum data transfer rate of 13.3 MB/s
- **MWDMA2** Multi Word DMA mode 2 selected with a maximum data transfer rate of 16.6 MB/s
- **UDMA0** Ultra DMA mode 0 selected with a maximum data transfer rate of 16.6 MB/s

- ➔ **UDMA1** Ultra DMA mode 1 selected with a maximum data transfer rate of 25 MB/s
- ➔ **UDMA2** Ultra DMA mode 2 selected with a maximum data transfer rate of 33.3 MB/s
- ➔ **UDMA3** Ultra DMA mode 3 selected with a maximum data transfer rate of 44 MB/s (To use this mode, it is required that an 80-conductor ATA cable is used.)
- ➔ **UDMA4** Ultra DMA mode 4 selected with a maximum data transfer rate of 66.6 MB/s (To use this mode, it is required that an 80-conductor ATA cable is used.)
- ➔ **UDMA5** Ultra DMA mode 5 selected with a maximum data transfer rate of 99.9 MB/s (To use this mode, it is required that an 80-conductor ATA cable is used.)

- **S.M.A.R.T [Auto]**

Use the **S.M.A.R.T** option to auto-detect, disable or enable Self-Monitoring Analysis and Reporting Technology (SMART) on the drive on the specified channel. **S.M.A.R.T** predicts impending drive failures. The **S.M.A.R.T** BIOS option enables or disables this function.

- ➔ **Auto** **DEFAULT** BIOS auto detects HDD SMART support.
- ➔ **Disabled** Prevents BIOS from using the HDD SMART feature.
- ➔ **Enabled** Allows BIOS to use the HDD SMART feature

- **32Bit Data Transfer [Enabled]**

Use the **32Bit Data Transfer** BIOS option to enables or disable 32-bit data transfers.

- ➔ **Disabled** Prevents the BIOS from using 32-bit data transfers.
- ➔ **Enabled** **DEFAULT** Allows BIOS to use 32-bit data transfers on supported hard disk drives.

AFL-W19A/W19B/17D/W15A-N270 Panel PC

3.3.3 Super IO Configuration

Use the **Super IO Configuration** menu (BIOS Menu 6) to set or change the configurations for the FDD controllers, parallel ports and serial ports.

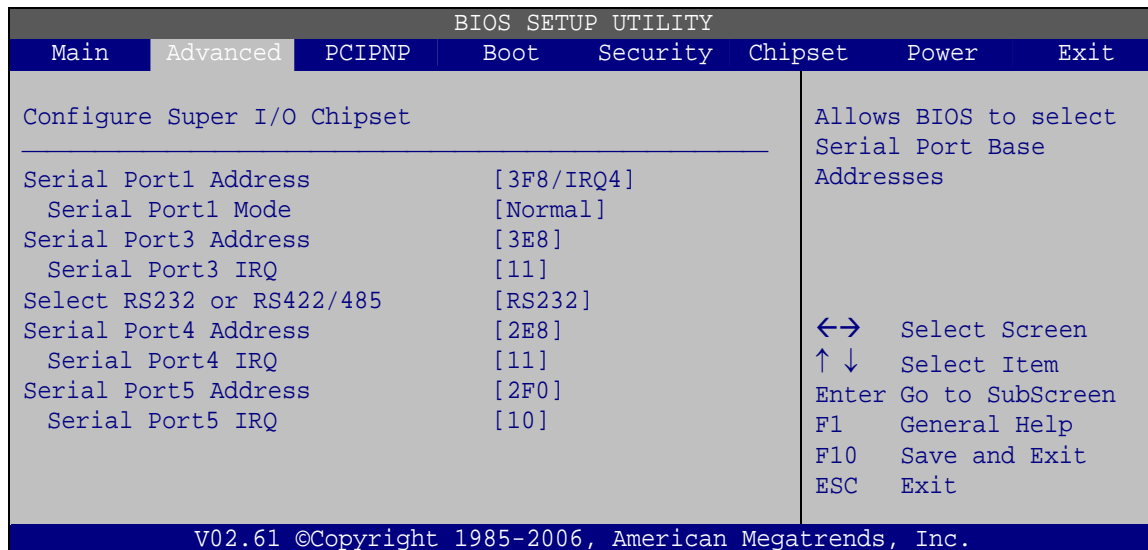

BIOS Menu 6: Super IO Configuration

- **Serial Port1 Address [3F8/IRQ4]**

Selects the serial port base address.

- ➔ **Disabled** No base address
- ➔ **3F8/IRQ4** **DEFAULT** I/O address 3F8 and interrupt address IRQ4
- ➔ **3E8/IRQ4** I/O address 3E8 and interrupt address IRQ4
- ➔ **2E8/IRQ3** I/O address 2E8 and interrupt address IRQ3

- **Serial Port1 Mode [Normal]**

Selects the mode for the serial port.

- ➔ **Normal** **DEFAULT** Normal mode
- ➔ **IrDA** IrDA mode
- ➔ **ASK IR** ASKIR mode

- **Serial Port3 Address [3E8]**

Selects the serial port base address.

- ➔ **Disabled** No base address
- ➔ **3E8** **DEFAULT** I/O address 3E8
- ➔ **2E8** I/O address 2E8
- ➔ **2F0** I/O address 2F0
- ➔ **2E0** I/O address 2E0

- **Serial Port3 IRQ [11]**

Selects the serial port interrupt address.

- ➔ **10** IRQ address 10
- ➔ **11** **DEFAULT** IRQ address 11

- **Select RS232 or RS422/RS485 [RS/232]**

Select the communication method for Serial Port 3.

- ➔ **RS232** **DEFAULT** Serial Port 2 signaling mode is RS-232
- ➔ **RS485** Serial Port 2 signaling mode is RS-485
- ➔ **RS422** Serial Port 2 signaling mode is RS-422

- **Serial Port4 Address [2E8]**

Selects the serial port base address.

- ➔ **Disabled** No base address
- ➔ **2E8** **DEFAULT** I/O address 2E8

- **Serial Port4 IRQ [11]**

Use the **Serial Port4 IRQ** option to select the interrupt address for serial port 4.

AFL-W19A/W19B/17D/W15A-N270 Panel PC

→ 11 DEFAULT IRQ address 11

- **Serial Port5 Address [2F0]**

Selects the serial port base address.

→ Disabled No base address

→ 2F0 DEFAULT I/O address 2F0

- **Serial Port5 IRQ [10]**

Use the **Serial Port5 IRQ** option to select the interrupt address for serial port 5.

→ 10 DEFAULT IRQ address 10

3.3.4 Hardware Health Configuration

The **Hardware Health Configuration** menu (BIOS Menu 7) shows the operating temperature, fan speeds and system voltages.

BIOS SETUP UTILITY		
Main	Advanced	Exit
Hardware Health Event Monitoring		
<hr/>		
CPU_FAN1 Mode Setting		[Automatic Mode]
CPU Temp. Limit of OFF		[000]
CPU Temp. Limit of Start		[020]
CPU_FAN1 Start PWM		[070]
Slope PWM 1		[0.5 PWM]
SYS_FAN1 Mode Setting		[Automatic Mode]
PWM Temp. Limit of OFF		[000]
PWM Temp. Limit of Start		[020]
SYS_FAN1 Start PWM		[070]
Slope PWM 2		[0.5 PWM]
<hr/>		
CPU Temperature		:68°C/154°F
System Temperature		:59°C/138°F
CPU Fan		:N/A
SYS Fan 1 Speed		:N/A
CPU Core		:1.056 V
+1.05V		:1.040 V
+3.30V		:3.264 V
+5.00V		:4.865 V
+12.0V		:11.904 V
+1.50V		:1.472 V
+1.80V		:1.792 V
5VSB		4.919 V
VBAT		3.184 V
		←→ Select Screen
		↑ ↓ Select Item
		Enter Go to SubScreen
		F1 General Help
		F10 Save and Exit
		ESC Exit
v02.61 ©Copyright 1985-2006, American Megatrends, Inc.		

BIOS Menu 7: Hardware Health Configuration

- **Mode Setting [Full On Mode]**

Use the **Mode Setting** option to configure the second fan.

➔ **Full On Mode** **DEFAULT** Fan is on all the time

AFL-W19A/W19B/17D/W15A-N270 Panel PC

➔ Automatic mode

The fan adjusts its speed using these settings:

Temp. Limit of OFF

Temp. Limit of Start

Fan Start PWM

Slope PWM 1

➔ PWM Manual mode

The fan spins at the speed set in:

Fan PWM control

▪ Temp. Limit of OFF [000]



WARNING:

CPU failure can result if this value is set too high

The fan will turn off if the temperature falls below this value.

- Minimum Value: 0°C
- Maximum Value: 127°C

▪ Temp. Limit of Start [020]



WARNING:

CPU failure can result if this value is set too high

When the fan is off, it will only start when the temperature exceeds this setting.

- Minimum Value: 0°C
- Maximum Value: 127°C

▪ Start PWM [070]

This is the initial speed of the fan when it first starts spinning.

- PWM Minimum Mode: 0

- PWM Maximum Mode: 127

- **Slope PWM [1 PWM]**

A bigger value will increase the fan speed in big amounts. A smaller value will increase the speed more gradually.

- 0 PWM
- 1 PWM
- 2 PWM
- 4 PWM
- 8 PWM
- 16 PWM
- 32 PWM
- 64 PWM

- **CPU Fan PWM Control [070]**

This value specifies the speed of the fan.

- PWM Minimum Mode: 0
- PWM Maximum Mode: 127

- **Monitored Values**

The following system parameters and values are shown. The system parameters that are monitored are:

- The following system temperatures are monitored:
 - CPU temperature
 - System temperature
- The following fan speeds are monitored:
 - CPU fan speed
 - SYS fan 1 speed
 - SYS fan 2 speed
- The following core voltages are monitored:
 - CPU core
 - +1.05V

AFL-W19A/W19B/17D/W15A-N270 Panel PC

- +3.30V
- +5.00V
- +12.0V
- +1.5V
- +1.8V

3.3.5 Power Configuration

The **Power Configuration** menu (BIOS Menu 8) allows the advanced power management options to be configured.

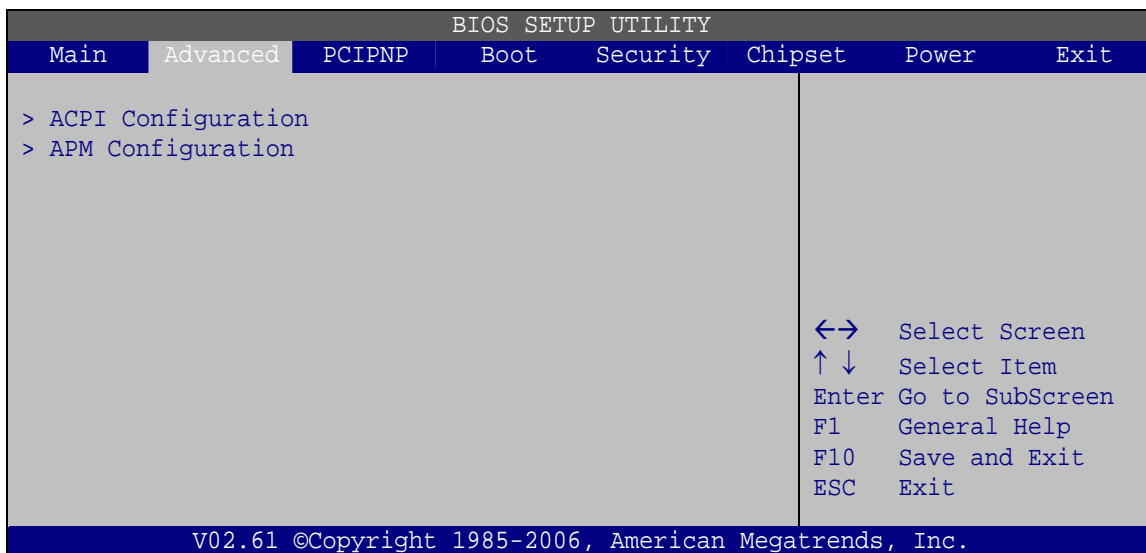

BIOS Menu 8: APM Configuration

3.3.5.1 ACPI Settings

Use the **ACPI Settings** menu (BIOS Menu 9) to select the ACPI state when the system is suspended.

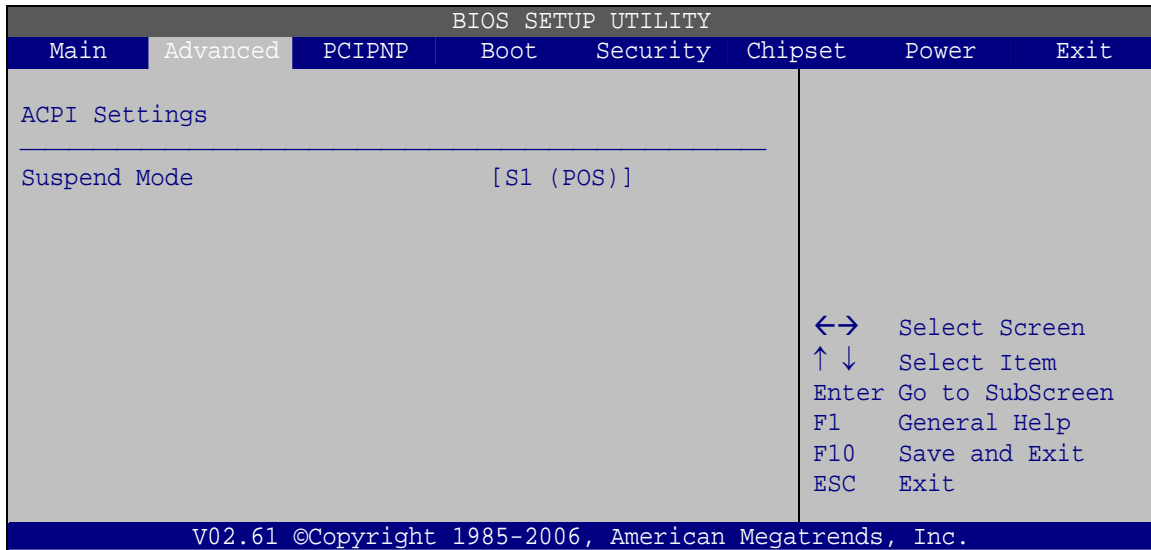

BIOS Menu 9: ACPI Settings

- **Suspend Mode [S1(POS)]**

Use the **Suspend Mode** option to specify the sleep state the system enters when it is not being used.

AFL-W19A/W19B/17D/W15A-N270 Panel PC

3.3.5.2 APM Configuration

The **APM Configuration** menu (BIOS Menu 10) allows the advanced power management options to be configured.

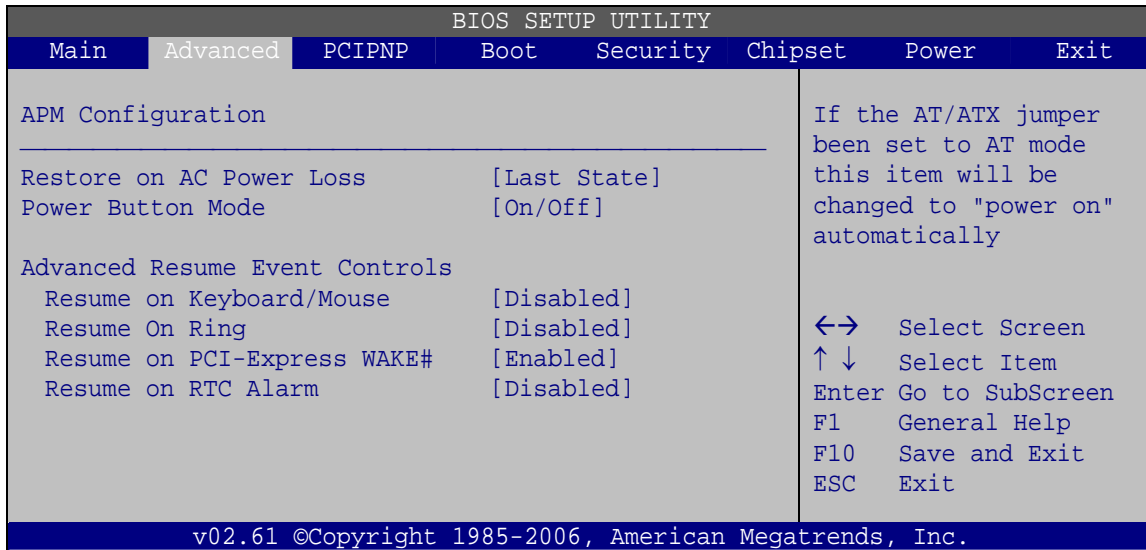

BIOS Menu 10: APM Configuration

- **Restore on AC Power Loss [Last State]**

Use the **Restore on AC Power Loss** BIOS option to specify what state the system returns to if there is a sudden loss of power to the system.

- ➔ **Power Off** The system remains turned off
- ➔ **Power On DEFAULT** The system turns on
- ➔ **Last State** The system returns to its previous state. If it was on, it turns itself on. If it was off, it remains off.

- **Power Button Mode [On/Off]**

Use the **Power Button Mode** BIOS to specify how the power button functions.

- ➔ **On/Off DEFAULT** When the power button is pressed the system is either turned on or off

AFL-W19A/W19B/17D/W15A-N270 Panel PC

- ➔ **Disabled** **DEFAULT** The real time clock (RTC) cannot generate a wake event

- ➔ **Enabled** If selected, the following appears with values that can be selected:
 - RTC Alarm Date (Days)
 - System Time
 After setting the alarm, the computer turns itself on from a suspend state when the alarm goes off.

3.3.6 Remote Access Configuration

Use the **Remote Access Configuration** menu (BIOS Menu 11) to configure remote access parameters. The **Remote Access Configuration** is an AMIBIOS feature and allows a remote host running a terminal program to display and configure the BIOS settings.

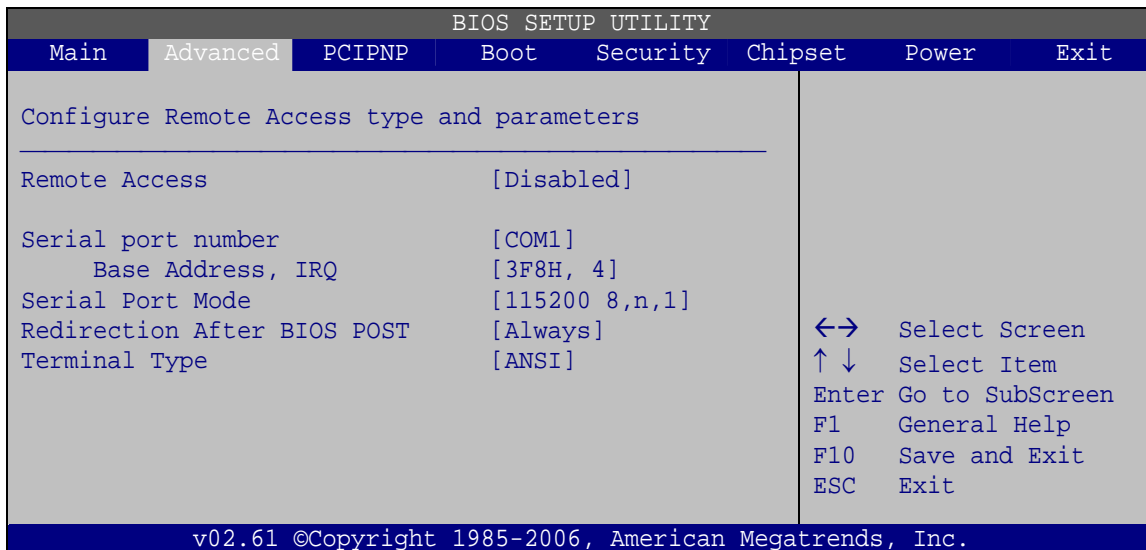

BIOS Menu 11: Remote Access Configuration

- **Remote Access [Disabled]**

Use the **Remote Access** option to enable or disable access to the remote functionalities of the system.

- ➔ **Disabled** **DEFAULT** Remote access is disabled.
- ➔ **Enabled** Remote access configuration options shown below appear:

- Serial Port Number
- Serial Port Mode
- Flow Control
- Redirection after BIOS POST
- Terminal Type
- VT-UTF8 Combo Key Support

These configuration options are discussed below.

- **Serial Port Number [COM1]**

Use the **Serial Port Number** option allows to select the serial port used for remote access.

- ➔ **COM1** **DEFAULT** System is remotely accessed through COM1
- ➔ **COM2** System is remotely accessed through COM2

NOTE: Make sure the selected COM port is enabled through the Super I/O configuration menu.

- **Base Address, IRQ [2F8h,3]**

The **Base Address, IRQ** option cannot be configured and only shows the interrupt address of the serial port listed above.

- **Serial Port Mode [115200 8,n,1]**

Use the **Serial Port Mode** option to select baud rate through which the console redirection is made. The following configuration options are available

- 115200 8,n,1 **DEFAULT**
- 57600 8,n,1
- 38400 8,n,1

AFL-W19A/W19B/17D/W15A-N270 Panel PC

- 19200 8,n,1
- 09600 8,n,1



NOTE:

Identical baud rate setting must be set on the host (a management computer running a terminal software) and the slave

▪ **Flow Control [None]**

Use the **Flow Control** option to report the flow control method for the console redirection application.

- ➔ **None** **DEFAULT** No control flow,
- ➔ **Hardware** Hardware is set as the console redirection
- ➔ **Software** Software is set as the console redirection

▪ **Redirection After BIOS POST [Always]**

Use the **Redirection After BIOS POST** option to specify when console redirection should occur.

- ➔ **Disabled** The console is not redirected after POST
- ➔ **Boot Loader** Redirection is active during POST and during Boot Loader
- ➔ **Always** **DEFAULT** Redirection is always active (Some OSES may not work if set to Always)

▪ **Terminal Type [ANSI]**

Use the **Terminal Type** BIOS option to specify the remote terminal type.

- ➔ **ANSI** **DEFAULT** The target terminal type is ANSI
- ➔ **VT100** The target terminal type is VT100

➔ **VT-UTF8** The target terminal type is VT-UTF8

▪ **VT-UTF8 Combo Key Support [Disabled]**

Use the **VT-UFT8 Combo Key Support** option to enable additional keys that are not provided by VT100 for the PC 101 keyboard.

The VT100 Terminal Definition is the standard convention used to configure and conduct emergency management tasks with UNIX-based servers. VT100 does not support all keys on the standard PC 101-key layout, however. The VT-UTF8 convention makes available additional keys that are not provided by VT100 for the PC 101 keyboard.

➔ **Disabled** **DEFAULT** Disables the VT-UTF8 terminal keys

➔ **Enabled** Enables the VT-UTF8 combination key. Support for ANSI/VT100 terminals

▪ **Sredir Memory Display Delay [Disabled]**

Use the **Sredir Memory Display Delay** option to select the delay before memory information is displayed. Configuration options are listed below

- No Delay **DEFAULT**
- Delay 1 sec
- Delay 2 sec
- Delay 4 sec

AFL-W19A/W19B/17D/W15A-N270 Panel PC

3.3.7 USB Configuration

Use the **USB Configuration** menu (BIOS Menu 12) to read USB configuration information and configure the USB settings.

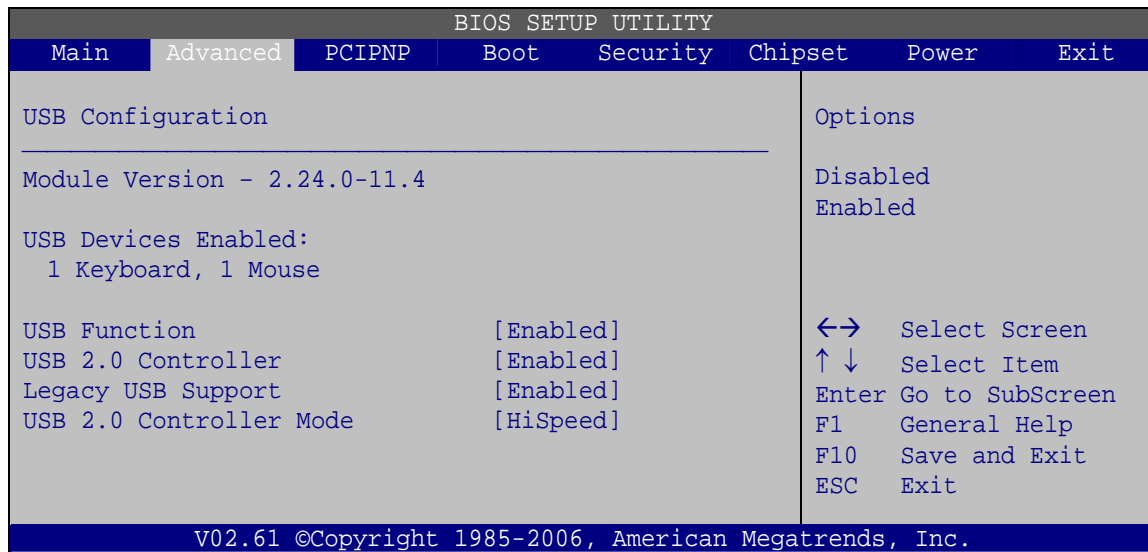

BIOS Menu 12: USB Configuration

- **USB Configuration**

The **USB Configuration** field shows the system USB configuration. The items listed are:

- Module Version: x.xxxxx.xxxxx

- **USB Devices Enabled**

The **USB Devices Enabled** field lists the USB devices that are enabled on the system

- **USB Function [Enabled]**

Use the **USB Function** BIOS option to enable or disable USB function support.

- ➔ **Disabled** USB function support disabled
- ➔ **Enabled** **DEFAULT** USB function support enabled

- **USB 2.0 Controller [Enabled]**

Use the **USB 2.0 Controller** BIOS option to enable or disable the USB 2.0 controller

- ➔ **Disabled** USB 2.0 controller disabled
- ➔ **Enabled** **DEFAULT** USB 2.0 controller enabled

- **Legacy USB Support [Enabled]**

Use the **Legacy USB Support** BIOS option to enable USB mouse and USB keyboard support.

Normally if this option is not enabled, any attached USB mouse or USB keyboard does not become available until a USB compatible operating system is fully booted with all USB drivers loaded. When this option is enabled, any attached USB mouse or USB keyboard can control the system even when there is no USB driver loaded onto the system.

- ➔ **Disabled** Legacy USB support disabled
- ➔ **Enabled** **DEFAULT** Legacy USB support enabled
- ➔ **Auto** Legacy USB support disabled if no USB devices are connected

- **USB2.0 Controller Mode [HiSpeed]**

Use the **USB2.0 Controller Mode** option to set the speed of the USB2.0 controller.

- ➔ **FullSpeed** The controller is capable of operating at 12 Mb/s
- ➔ **HiSpeed** **DEFAULT** The controller is capable of operating at 480 Mb/s

AFL-W19A/W19B/17D/W15A-N270 Panel PC

3.3.7.1 USB Mass Storage Device Configuration

Use the **USB Mass Storage Device Configuration** menu (BIOS Menu 13) to configure USB mass storage class devices.

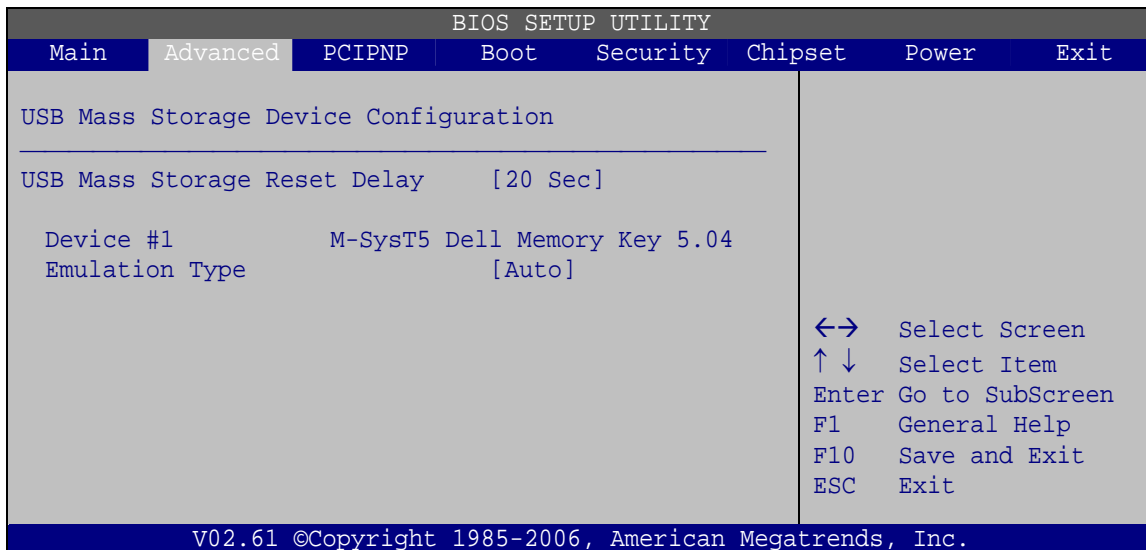

BIOS Menu 13: USB Mass Storage Device Configuration

- **USB Mass Storage Reset Delay [20 Sec]**

Use the **USB Mass Storage Reset Delay** option to set the number of seconds POST waits for the USB mass storage device after the start unit command.

- ➔ **10 Sec** POST waits 10 seconds for the USB mass storage device after the start unit command.
- ➔ **20 Sec** **DEFAULT** POST waits 20 seconds for the USB mass storage device after the start unit command.
- ➔ **30 Sec** POST waits 30 seconds for the USB mass storage device after the start unit command.
- ➔ **40 Sec** POST waits 40 seconds for the USB mass storage device after the start unit command.

- **Device ##**

The **Device##** field lists the USB devices that are connected to the system.

- **Emulation Type [Auto]**

Use the **Emulation Type** BIOS option to specify the type of emulation BIOS has to provide for the USB device.

- ➔ **Auto** **DEFAULT** BIOS auto-detects the current USB.
- ➔ **Floppy** The USB device will be emulated as a floppy drive. The device can be either A: or B: responding to INT13h calls that return DL = 0 or DL = 1 respectively.
- ➔ **Forced FDD** Allows a hard disk image to be connected as a floppy image. This option works only for drives formatted with FAT12, FAT16 or FAT32.
- ➔ **Hard Disk** Allows the USB device to be emulated as hard disk responding to INT13h calls that return DL values of 80h or above.
- ➔ **CDROM** Assumes the CD-ROM is formatted as bootable media. All the devices that support block sizes greater than 512 bytes can only be booted using this option.

3.4 PCI/PnP

Use the **PCI/PnP** menu (BIOS Menu 14) to configure advanced PCI and PnP settings.



WARNING!

Setting wrong values for the BIOS selections in the PCIPnP BIOS menu may cause the system to malfunction.

AFL-W19A/W19B/17D/W15A-N270 Panel PC

BIOS SETUP UTILITY		
Main	Advanced	PCIPNP
Advanced PCI/PnP Settings		Available: Specified IRQ is available to be use the PCI/PnP devices
IRQ3	[Reserved]	Reserved: Specified IRQ is reserved for use by legacy ISA devices
IRQ4	[Reserved]	
IRQ5	[Available]	
IRQ7	[Available]	
IRQ9	[Available]	
IRQ10	[Reserved]	
IRQ11	[Reserved]	
IRQ14	[Available]	
IRQ15	[Available]	
DMA Channel 0	[Available]	
DMA Channel 1	[Available]	
DMA Channel 3	[Available]	←→ Select Screen
DMA Channel 5	[Available]	↑ ↓ Select Item
DMA Channel 6	[Available]	Enter Go to SubScreen
DMA Channel 7	[Available]	F1 General Help
Reserved Memory Size	[Disabled]	F10 Save and Exit
		ESC Exit
v02.61 ©Copyright 1985-2006, American Megatrends, Inc.		

BIOS Menu 14: PCI/PnP Configuration

- **IRQ# [Available]**

Use the **IRQ#** address to specify what IRQs can be assigned to a particular peripheral device.

- ➔ **Available** **DEFAULT** The specified IRQ is available to be used by PCI/PnP devices
- ➔ **Reserved** The specified IRQ is reserved for use by Legacy ISA devices

Available IRQ addresses are:

- IRQ3
- IRQ4
- IRQ5
- IRQ7
- IRQ9
- IRQ10

- IRQ 11
- IRQ 14
- IRQ 15

- **DMA Channel# [Available]**

Use the **DMA Channel#** option to assign a specific DMA channel to a particular PCI/PnP device.

- ➔ **Available** **DEFAULT** The specified DMA is available to be used by PCI/PnP devices
- ➔ **Reserved** The specified DMA is reserved for use by Legacy ISA devices

Available DMA Channels are:

- DM Channel 0
- DM Channel 1
- DM Channel 3
- DM Channel 5
- DM Channel 6
- DM Channel 7

- **Reserved Memory Size [Disabled]**

Use the **Reserved Memory Size** BIOS option to specify the amount of memory that should be reserved for legacy ISA devices.

- ➔ **Disabled** **DEFAULT** No memory block reserved for legacy ISA devices
- ➔ **16K** 16 KB reserved for legacy ISA devices
- ➔ **32K** 32 KB reserved for legacy ISA devices
- ➔ **64K** 64 KB reserved for legacy ISA devices

AFL-W19A/W19B/17D/W15A-N270 Panel PC

3.5 Boot

Use the **Boot** menu (BIOS Menu 15) to configure system boot options.

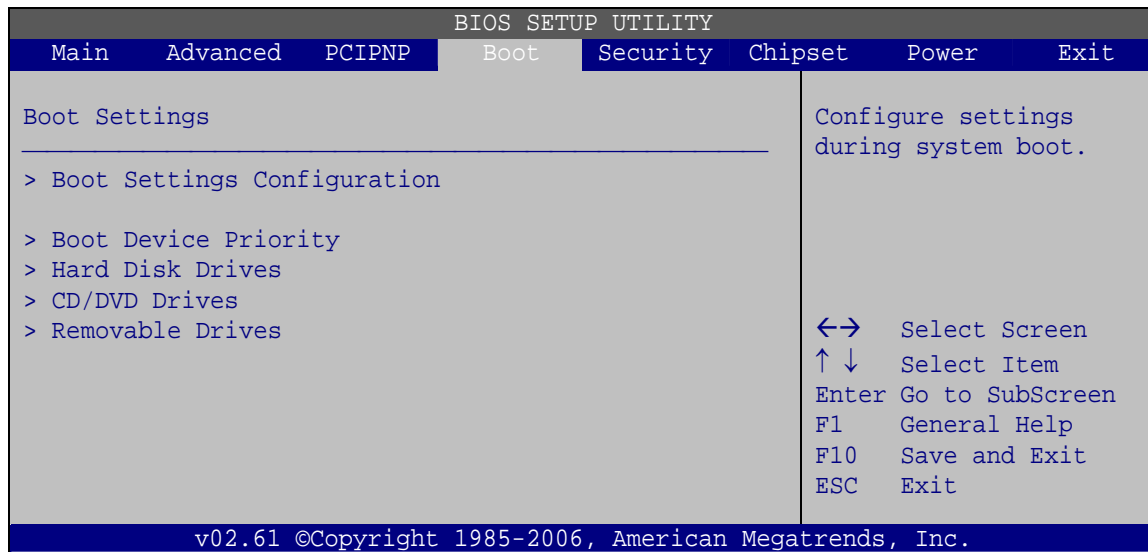

BIOS Menu 15: Boot

3.5.1 Boot Settings Configuration

Use the **Boot Settings Configuration** menu (BIOS Menu 16) to configure advanced system boot options.

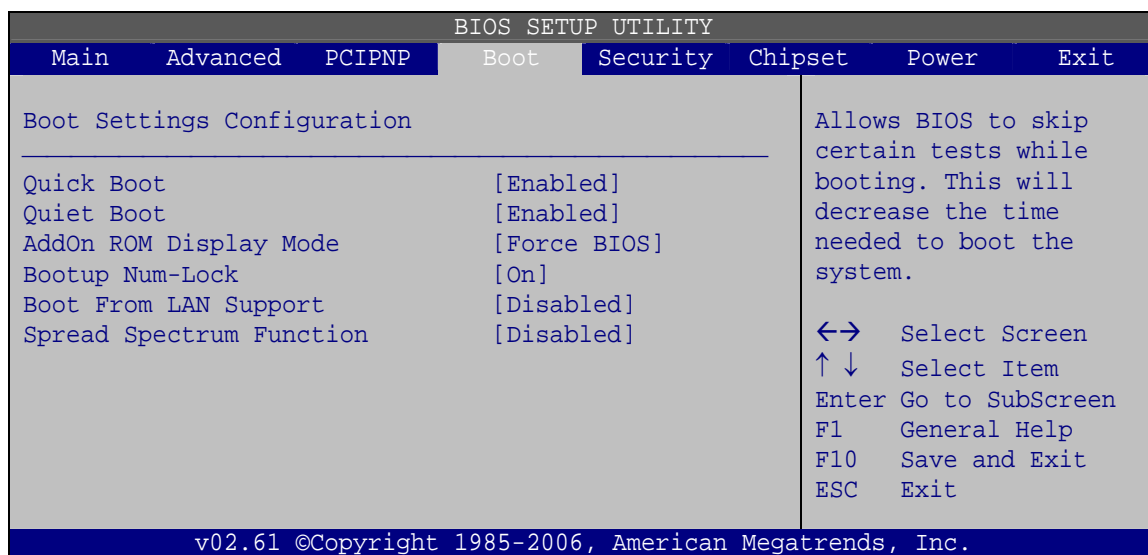

BIOS Menu 16: Boot Settings Configuration

- **Quick Boot [Enabled]**

Use the **Quick Boot** BIOS option to make the computer speed up the boot process.

- ➔ **Disabled** No POST procedures are skipped
- ➔ **Enabled DEFAULT** Some POST procedures are skipped to decrease the system boot time

- **Quiet Boot [Enabled]**

Use the **Quiet Boot** BIOS option to select the screen display when the system boots.

- ➔ **Disabled DEFAULT** Normal POST messages displayed
- ➔ **Enabled** OEM Logo displayed instead of POST messages

- **AddOn ROM Display Mode [Force BIOS]**

Use the **AddOn ROM Display Mode** option to allow add-on ROM (read-only memory) messages to be displayed.

- ➔ **Force BIOS DEFAULT** The system forces third party BIOS to display during system boot.
- ➔ **Keep Current** The system displays normal information during system boot.

- **Bootup Num-Lock [On]**

Use the **Bootup Num-Lock** BIOS option to specify if the number lock setting must be modified during boot up.

- ➔ **Off** Does not enable the keyboard Number Lock automatically. To use the 10-keys on the keyboard, press the Number Lock key located on the upper left-hand corner of the 10-key pad. The Number Lock LED on the keyboard lights up when the Number Lock is engaged.

AFL-W19A/W19B/17D/W15A-N270 Panel PC

- ➔ **On** **DEFAULT** Allows the Number Lock on the keyboard to be enabled automatically when the computer system boots up. This allows the immediate use of the 10-key numeric keypad located on the right side of the keyboard. To confirm this, the Number Lock LED light on the keyboard is lit.

- **Boot From LAN Support [Disabled]**

Use the **BOOT From LAN Support** option to enable the system to be booted from a remote system.

- ➔ **Disabled** **DEFAULT** Cannot be booted from a remote system through the LAN
- ➔ **Enabled** **DEFAULT** Can be booted from a remote system through the LAN

- **Spread Spectrum Mode [Disabled]**

The **Spread Spectrum Mode** option can help to improve CPU EMI issues.

- ➔ **Disabled** **DEFAULT** The spread spectrum mode is disabled
- ➔ **Enabled** The spread spectrum mode is enabled

3.5.2 Boot Device Priority

Use the **Boot Device Priority** menu (BIOS Menu 17) to specify the boot sequence from the available devices. The drive sequence also depends on the boot sequence in the individual device section.

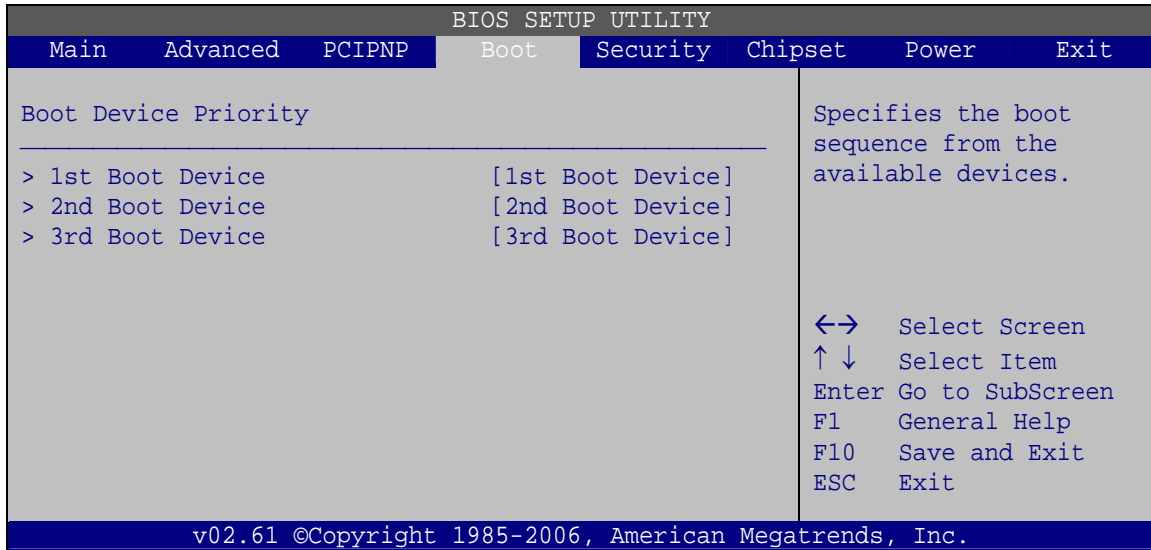

BIOS Menu 17: Boot Device Priority Settings

AFL-W19A/W19B/17D/W15A-N270 Panel PC

3.5.3 Hard Disk Drives

Use the **Hard Disk Drives** menu to specify the boot sequence of the available HDDs. Only installed hard drives are shown.

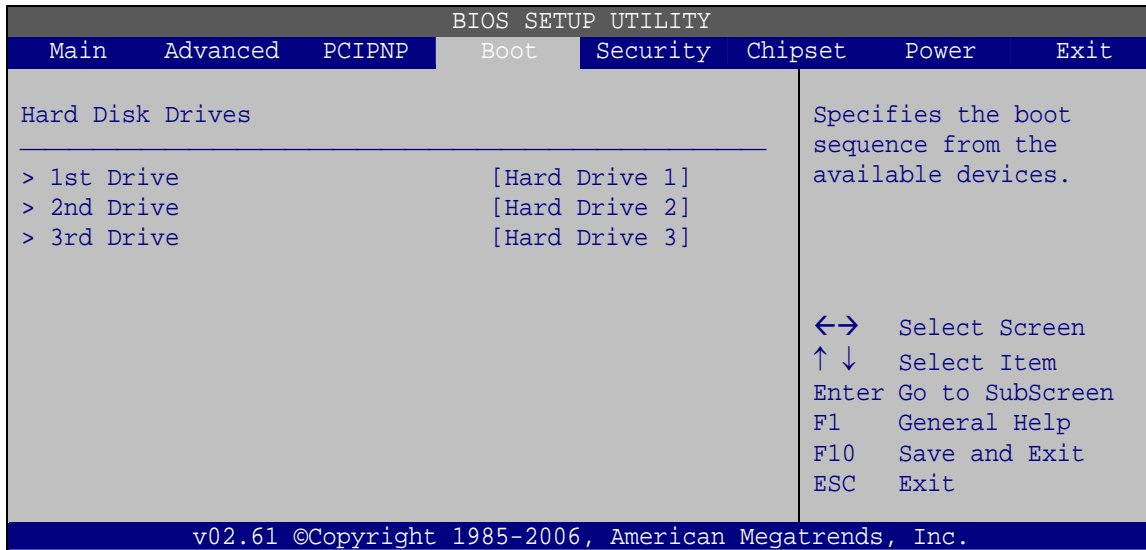

BIOS Menu 18: Hard Disk Drives

3.5.4 Removable Drives

Use the **Removable Drives** menu (BIOS Menu 19) to specify the boot sequence of the removable drives. Only connected drives are shown.

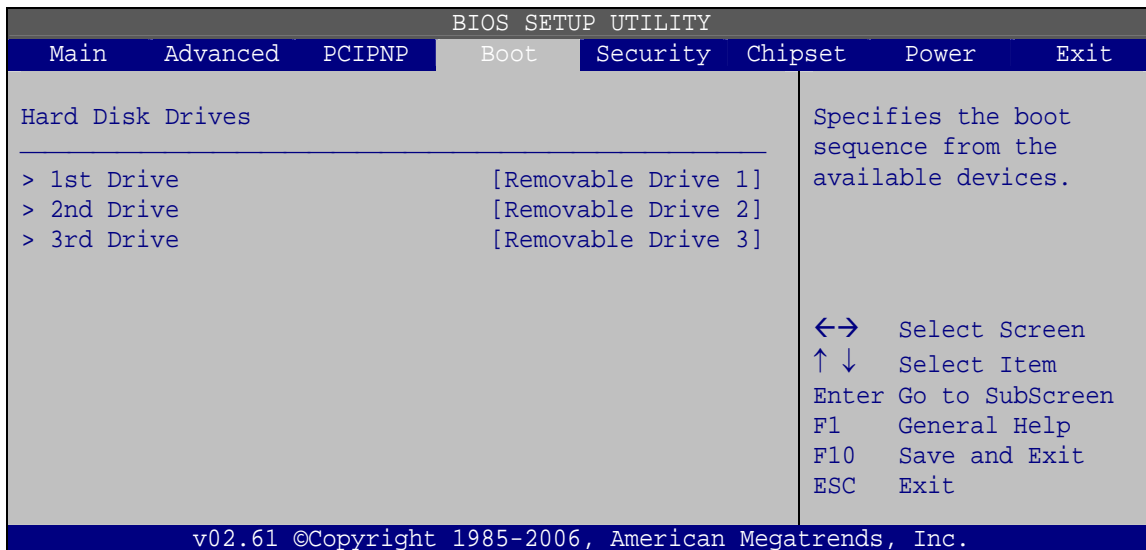

BIOS Menu 19: Removable Drives

3.5.5 CD/DVD Drives

Use the **CD/DVD Drives** menu to specify the boot sequence of the available CD/DVD drives. When the menu is opened, the CD drives and DVD drives connected to the system are listed as shown below:

- 1st Drive [CD/DVD: PM-(part ID)]
- 2nd Drive [HDD: PS-(part ID)]
- 3rd Drive [HDD: SM-(part ID)]
- 4th Drive [HDD: SM-(part ID)]



NOTE:

Only the drives connected to the system are shown. For example, if only two CDs or DVDs are connected only **“1st Drive”** and **“2nd Drive”** are listed.

The boot sequence from the available devices is selected. If the **“1st Drive”** option is selected a list of available CD/DVD drives is shown. Select the first CD/DVD drive the system boots from. If the **“1st Drive”** is not used for booting this option may be disabled.

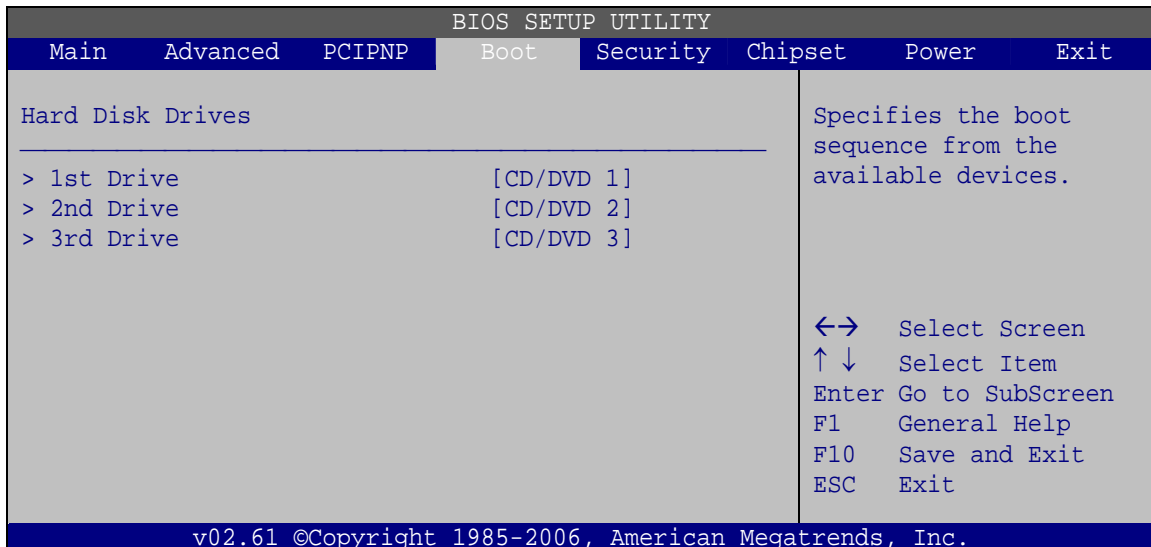

BIOS Menu 20: CD/DVD Drives

3.6 Security

Use the **Security** menu (BIOS Menu 21) to set system and user passwords.

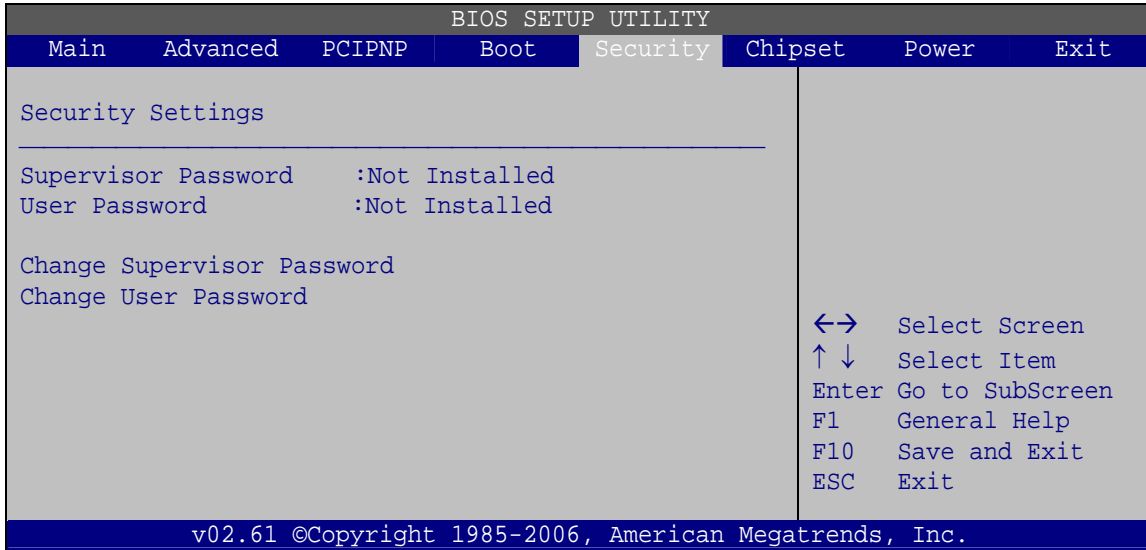

BIOS Menu 21: Security

- **Change Supervisor Password**

Use the **Change Supervisor Password** to set or change a supervisor password. The default for this option is **Not Installed**. If a supervisor password must be installed, select this field and enter the password. After the password has been added, **Install** appears next to **Change Supervisor Password**.

- **Change User Password**

Use the **Change User Password** to set or change a user password. The default for this option is **Not Installed**. If a user password must be installed, select this field and enter the password. After the password has been added, **Install** appears next to **Change User Password**.

3.7 Chipset

Use the **Chipset** menu (BIOS Menu 22) to access the Northbridge and Southbridge configuration menus



WARNING!

Setting the wrong values for the Chipset BIOS selections in the Chipset BIOS menu may cause the system to malfunction.

```

BIOS SETUP UTILITY
Main  Advanced  PCIPNP  Boot  Security  Chipset  Power  Exit
-----
Chipset
-----
> Northbridge Configuration
> Southbridge Configuration

                                  ←→  Select Screen
                                  ↑↓  Select Item
                                  Enter Go to SubScreen
                                  F1   General Help
                                  F10  Save and Exit
                                  ESC  Exit

v02.61 ©Copyright 1985-2006, American Megatrends, Inc.
    
```

BIOS Menu 22: Chipset

AFL-W19A/W19B/17D/W15A-N270 Panel PC

3.7.1 Northbridge Configuration

Use the **Northbridge Chipset Configuration** menu (BIOS Menu 23) to configure the Northbridge chipset.

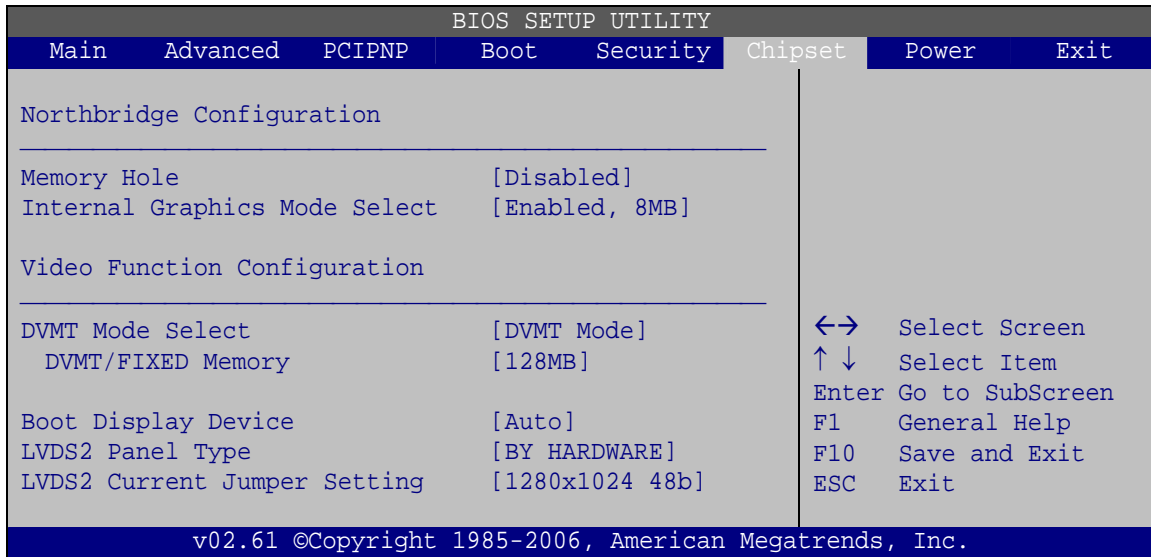

BIOS Menu 23:Northbridge Chipset Configuration

- **Memory Hole [Disabled]**

Use the **Memory Hole** option to reserve memory space between 15 MB and 16 MB for ISA expansion cards that require a specified area of memory to work properly. If an older ISA expansion card is used, please refer to the documentation that came with the card to see if it is necessary to reserve the space.

- ➔ **Disabled** **DEFAULT** Memory is not reserved for ISA expansion cards
- ➔ **15 MB–16 MB** Between 15 MB and 16 MB of memory is reserved for ISA expansion cards

- **Internal Graphics Mode Select [Enable, 8 MB]**

Use the **Internal Graphic Mode Select** option to specify the amount of system memory that can be used by the Internal graphics device.

- ➔ **Disable** Disabled the onboard graphics

- ➔ **Enable, 1 MB** Dedicates 1 MB of main memory for graphics
- ➔ **Enable, 8 MB** **DEFAULT** Dedicated 8 MB of main memory for graphics

- **DVMT Mode Select [DVMT Mode]**

Use the **DVMT Mode Select** option to select the Intel Dynamic Video Memory Technology (DVMT) operating mode.

- ➔ **Fixed Mode** A fixed portion of graphics memory is reserved as graphics memory.
- ➔ **DVMT Mode** **DEFAULT** Graphics memory is dynamically allocated according to the system and graphics needs.
- ➔ **Combo Mode** A fixed portion of graphics memory is reserved as graphics memory. If more memory is needed, graphics memory is dynamically allocated according to the system and graphics needs.

- **DVMT/FIXED Memory [128 MB]**

Use the **DVMT/FIXED Memory** option to specify the maximum amount of memory that can be allocated as graphics memory. This option can only be configured for if **DVMT Mode** or **Fixed Mode** is selected in the **DVMT Mode Select** option. If **Combo Mode** is selected, the maximum amount of graphics memory is 128 MB. Configuration options are listed below.

- 64 MB
- 128 MB **DEFAULT**
- Maximum DVMT

- **Boot Display Device [Auto]**

Selects which graphics output to use first after the system is turned on. Auto selects the first available device.

- Auto **DEFAULT**
- CRT

AFL-W19A/W19B/17D/W15A-N270 Panel PC

- LVDS
- **Panel Type**

Use the **Panel Type** to determine the LCD panel resolution. Configuration options are listed below:

- 1024x768 24b
 - 1280x1024 48b
 - 1366x768 24b
 - 1440x900 48b
 - BY HARDWARE **DEFAULT**
- **Current Jumper Setting**

Shows current value of the hardware jumper setting for the LVDS resolution. This is the value used when "BY HARDWARE" is selected in the setting above.

3.7.2 Southbridge Configuration

The **Southbridge Configuration** menu (BIOS Menu 24) the Southbridge chipset to be configured.

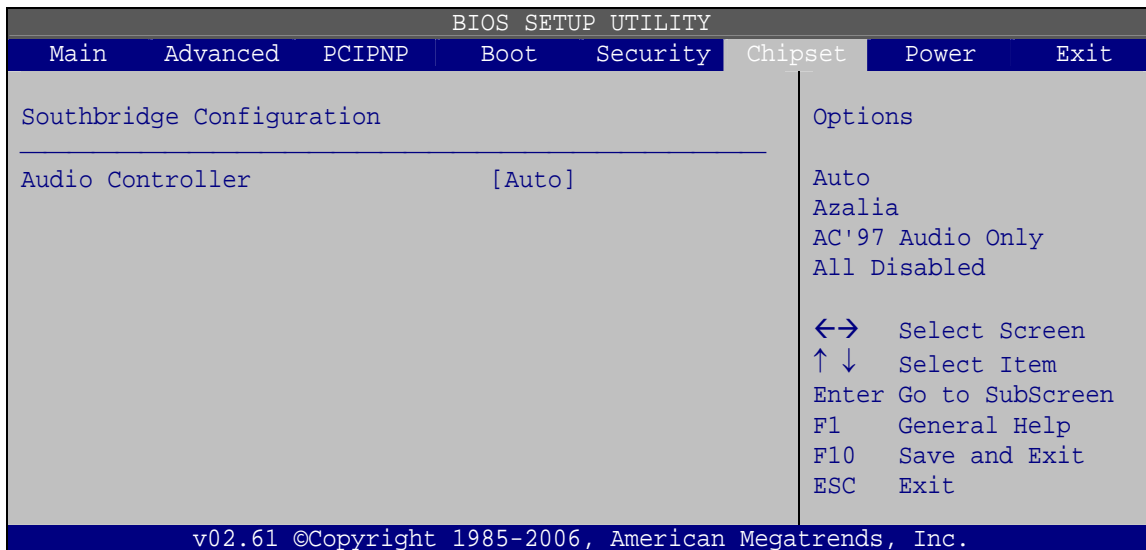

BIOS Menu 24:Southbridge Chipset Configuration

- **Audio Controller [Auto]**

Use the **HDA Controller** option to enable or disable High Definition audio codec.

- ➔ **Auto** DEFAULT
- ➔ **Azalia** Enabled High Definition audio
- ➔ **AC'97 Audio Only** Enable AC'97 audio
- ➔ **All disabled** No audio

3.8 Exit

Use the **Exit** menu (BIOS Menu 25) to load default BIOS values, optimal failsafe values and to save configuration changes.

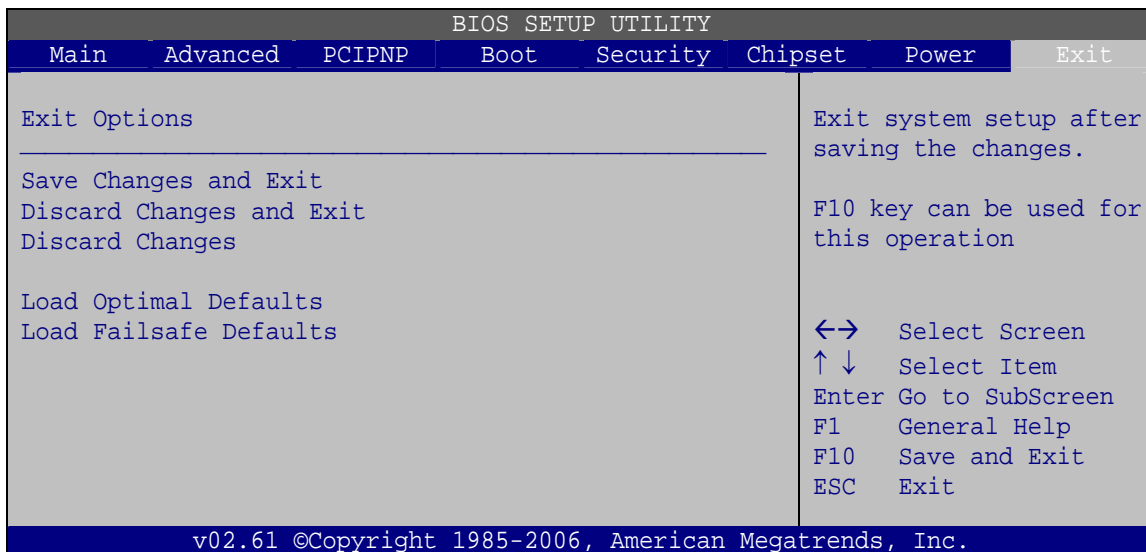

BIOS Menu 25:Exit

- **Save Changes and Exit**

Use the **Save Changes and Exit** option to save the changes made to the BIOS options and to exit the BIOS configuration setup program.

- **Discard Changes and Exit**

Use the **Discard Changes and Exit** option to exit the BIOS configuration setup program without saving the changes made to the system.

AFL-W19A/W19B/17D/W15A-N270 Panel PC

- **Discard Changes**

Use the **Discard Changes** option to discard the changes and remain in the BIOS configuration setup program.

- **Load Optimal Defaults**

Use the **Load Optimal Defaults** option to load the optimal default values for each of the parameters on the Setup menus. **F9 key can be used for this operation.**

- **Load Failsafe Defaults**

Use the **Load Failsafe Defaults** option to load failsafe default values for each of the parameters on the Setup menus. **F8 key can be used for this operation.**



Chapter

4

System Maintenance

AFL-W19A/W19B/17D/W15A-N270 Panel PC

4.1 System Maintenance Introduction

If the components of the AFL-W19A/W19B/17D/W15A-N270 fail they must be replaced, such as the wireless LAN module or the motherboard. Please contact the system reseller or vendor to purchase the replacement parts. Back cover removal instructions and jumper settings for the AFL-W19A/W19B/17D/W15A-N270 are described below.

4.2 Motherboard Replacement

In the case of motherboard failure, please contact an IEI sales representative, reseller or system vendor. The motherboard is accessible after opening the rear cover.

4.3 Cover Removal



WARNING!

Turn off the power before removing the back cover. Risk of electrocution. Severe damage to the product and injury to the body may occur if internal parts are touched while the power is still on.



WARNING!

Take antistatic precautions when working on the internal components. Some internal components are easily damaged or destroyed by electrostatic discharge. Take antistatic precautions to prevent electrostatic discharge.

To replace any of the following components,

- Memory module
- Wireless LAN module
- Inverter

The back cover of the AFL-W19A/W19B/17D/W15A-N270 must be removed. To remove the back cover, loosen the four silver screws, slide the cover down and then lift to remove.



Figure 4-1: Back Cover Retention Screws

4.4 Memory Module Replacement

The flat panel PC has a preinstalled memory module. If the memory module fails, take the steps below to replace it.

- Step 1:** Remove the back cover. See **Section 4.3** above.
- Step 2:** Locate the memory module on the motherboard of the flat panel PC
- Step 3:** Remove the memory module by pulling both the spring retainer clips outward from the socket.
- Step 4:** Grasp the memory module by the edges and carefully pull it out of the socket.
- Step 5:** Install the new memory module by inserting it at an angle, then pushing down until the clips snap into place (Figure 4-2).

AFL-W19A/W19B/17D/W15A-N270 Panel PC

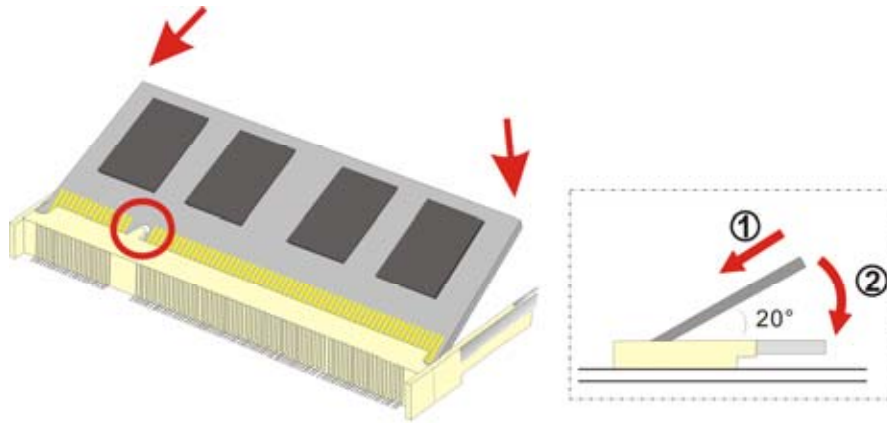

Figure 4-2: DDR SO-DIMM Module Installation

Appendix

A

Safety Precautions



WARNING:

The precautions outlined in this chapter should be strictly followed. Failure to follow these precautions may result in permanent damage to the AFL-W19A/W19B/17D/W15A-N270.

A.1 Safety Precautions

Please follow the safety precautions outlined in the sections that follow:

A.1.1 General Safety Precautions

Please ensure the following safety precautions are adhered to at all times.

- **Follow the electrostatic precautions** outlined below whenever the AFL-W19A/W19B/17D/W15A-N270 is opened.
- **Make sure the power is turned off and the power cord is disconnected** whenever the AFL-W19A/W19B/17D/W15A-N270 is being installed, moved or modified.
- **Do not apply voltage levels that exceed the specified voltage range.** Doing so may cause fire and/or an electrical shock.
- **Electric shocks can occur** if the AFL-W19A/W19B/17D/W15A-N270 chassis is opened when the AFL-W19A/W19B/17D/W15A-N270 is running.
- **Do not drop or insert any objects** into the ventilation openings of the AFL-W19A/W19B/17D/W15A-N270.
- **If considerable amounts of dust, water, or fluids enter the AFL-W19A/W19B/17D/W15A-N270**, turn off the power supply immediately, unplug the power cord, and contact the AFL-W19A/W19B/17D/W15A-N270 vendor.
- **DO NOT** do the following:
 - **DO NOT** drop the AFL-W19A/W19B/17D/W15A-N270 against a hard surface.
 - **DO NOT** strike or exert excessive force onto the LCD panel.
 - **DO NOT** touch any of the LCD panels with a sharp object

- **DO NOT** use the AFL-W19A/W19B/17D/W15A-N270 in a site where the ambient temperature exceeds the rated temperature

A.1.2 Anti-static Precautions



WARNING:

Failure to take ESD precautions during the installation of the AFL-W19A/W19B/17D/W15A-N270 may result in permanent damage to the AFL-W19A/W19B/17D/W15A-N270 and sever injury to the user.

Electrostatic discharge (ESD) can cause serious damage to electronic components, including the AFL-W19A/W19B/17D/W15A-N270. Dry climates are especially susceptible to ESD. It is therefore critical that whenever the AFL-W19A/W19B/17D/W15A-N270 is opened and any of the electrical components are handled, the following anti-static precautions are strictly adhered to.

- ***Wear an anti-static wristband:*** Wearing a simple anti-static wristband can help to prevent ESD from damaging any electrical component.
- ***Self-grounding:*** Before handling any electrical component, touch any grounded conducting material. During the time the electrical component is handled, frequently touch any conducting materials that are connected to the ground.
- ***Use an anti-static pad:*** When configuring or working with an electrical component, place it on an antic-static pad. This reduces the possibility of ESD damage.
- ***Only handle the edges of the electrical component:*** When handling the electrical component, hold the electrical component by its edges.

A.2 Maintenance and Cleaning Precautions

When maintaining or cleaning the AFL-W19A/W19B/17D/W15A-N270, please follow the guidelines below.

AFL-W19A/W19B/17D/W15A-N270 Panel PC

A.2.1 Maintenance and Cleaning

Prior to cleaning any part or component of the AFL-W19A/W19B/17D/W15A-N270, please read the details below.

- Except for the LCD panel, never spray or squirt liquids directly onto any other components. To clean the LCD panel, gently wipe it with a piece of soft dry cloth or a slightly moistened cloth.
- The interior does not require cleaning. Keep fluids away from the interior.
- Be careful not to damage the small, removable components inside.
- Turn off before cleaning.
- Never drop any objects or liquids through the openings.
- Be cautious of any possible allergic reactions to solvents or chemicals used when cleaning.
- Avoid eating, drinking and smoking nearby.

A.2.2 Cleaning Tools

Some components may only be cleaned using a product specifically designed for the purpose. In such case, the product will be explicitly mentioned in the cleaning tips. Below is a list of items to use for cleaning.

- **Cloth** – Although paper towels or tissues can be used, a soft, clean piece of cloth is recommended.
- **Water or rubbing alcohol** – A cloth moistened with water or rubbing alcohol should be used.
- **Using solvents** – The use of solvents is not recommended as they may damage the plastic parts.
- **Vacuum cleaner** – Using a vacuum specifically designed for computers is one of the best methods of cleaning. Dust and dirt can restrict the airflow and cause circuitry to corrode
- **Cotton swabs** - Cotton swabs moistened with rubbing alcohol or water are excellent tools for wiping hard to reach areas.
- **Foam swabs** - Whenever possible, it is best to use lint free swabs such as foam swabs for cleaning.



Appendix

B

BIOS Options

AFL-W19A/W19B/17D/W15A-N270 Panel PC

Below is a list of BIOS configuration options in the BIOS chapter.

▪ System Overview	30
▪ System Time [xx:xx:xx]	31
▪ System Date [xx/xx/xx]	31
▪ ATA/IDE Configuration [Compatible]	33
▪ Legacy IDE Channels [SATA Pri, PATA Sec]	33
▪ Configure SATA as [IDE]	34
▪ Auto-Detected Drive Parameters	34
▪ Type [Auto]	35
▪ LBA/Large Mode [Auto]	36
▪ Block (Multi Sector Transfer) [Auto]	36
▪ PIO Mode [Auto]	36
▪ DMA Mode [Auto]	37
▪ S.M.A.R.T [Auto]	38
▪ 32Bit Data Transfer [Enabled]	38
▪ Serial Port1 Address [3F8/IRQ4]	39
▪ Serial Port1 Mode [Normal]	39
▪ Serial Port3 Address [3E8]	40
▪ Serial Port3 IRQ [11]	40
▪ Select RS232 or RS422/RS485 [RS/232]	40
▪ Serial Port4 Address [2E8]	40
▪ Serial Port4 IRQ [11]	40
▪ Serial Port5 Address [2F0]	41
▪ Serial Port5 IRQ [10]	41
▪ Mode Setting [Full On Mode]	42
▪ Temp. Limit of OFF [000]	43
▪ Temp. Limit of Start [020]	43
▪ Start PWM [070]	43
▪ Slope PWM [1 PWM]	44
▪ CPU Fan PWM Control [070]	44
▪ Monitored Values	44
▪ Suspend Mode [S1(POS)]	46
▪ Restore on AC Power Loss [Last State]	47
▪ Power Button Mode [On/Off]	47

▪ Resume on Keyboard/Mouse [Disabled]	48
▪ Resume on Ring [Disabled]	48
▪ Resume on PCI-Express WAKE# [Enabled].....	48
▪ Resume On RTC Alarm [Disabled].....	48
▪ Remote Access [Disabled].....	49
▪ Serial Port Number [COM1].....	50
▪ Base Address, IRQ [2F8h,3].....	50
▪ Serial Port Mode [115200 8,n,1].....	50
▪ Flow Control [None].....	51
▪ Redirection After BIOS POST [Always]	51
▪ Terminal Type [ANSI].....	51
▪ VT-UTF8 Combo Key Support [Disabled].....	52
▪ Sredir Memory Display Delay [Disabled].....	52
▪ USB Configuration.....	53
▪ USB Devices Enabled	53
▪ USB Function [Enabled].....	53
▪ USB 2.0 Controller [Enabled].....	54
▪ Legacy USB Support [Enabled].....	54
▪ USB2.0 Controller Mode [HiSpeed].....	54
▪ USB Mass Storage Reset Delay [20 Sec]	55
▪ Device ##.....	55
▪ Emulation Type [Auto].....	56
▪ IRQ# [Available]	57
▪ DMA Channel# [Available]	58
▪ Reserved Memory Size [Disabled]	58
▪ Quick Boot [Enabled]	60
▪ Quiet Boot [Enabled]	60
▪ AddOn ROM Display Mode [Force BIOS]	60
▪ Bootup Num-Lock [On]	60
▪ Boot From LAN Support [Disabled]	61
▪ Spread Spectrum Mode [Disabled]	61
▪ Change Supervisor Password.....	65
▪ Change User Password.....	65
▪ Memory Hole [Disabled].....	67
▪ Internal Graphics Mode Select [Enable, 8 MB]	67

AFL-W19A/W19B/17D/W15A-N270 Panel PC

▪ DVMT Mode Select [DVMT Mode].....	68
▪ DVMT/FIXED Memory [128 MB]	68
▪ Boot Display Device [Auto].....	68
▪ Panel Type	69
▪ Current Jumper Setting.....	69
▪ Audio Controller [Auto]	70
▪ Save Changes and Exit	70
▪ Discard Changes and Exit.....	70
▪ Discard Changes.....	71
▪ Load Optimal Defaults.....	71
▪ Load Failsafe Defaults.....	71



Appendix

C

Terminology

AFL-W19A/W19B/17D/W15A-N270 Panel PC

AC '97	Audio Codec 97 (AC'97) refers to a codec standard developed by Intel® in 1997.
ACPI	Advanced Configuration and Power Interface (ACPI) is an OS-directed configuration, power management, and thermal management interface.
AHCI	Advanced Host Controller Interface (AHCI) is a SATA Host controller register-level interface.
ATA	The Advanced Technology Attachment (ATA) interface connects storage devices including hard disks and CD-ROM drives to a computer.
ARMD	An ATAPI Removable Media Device (ARMD) is any ATAPI device that supports removable media, besides CD and DVD drives.
ASKIR	Amplitude Shift Keyed Infrared (ASKIR) is a form of modulation that represents a digital signal by varying the amplitude (“volume”) of the signal. A low amplitude signal represents a binary 0, while a high amplitude signal represents a binary 1.
BIOS	The Basic Input/Output System (BIOS) is firmware that is first run when the computer is turned on and can be configured by the end user
CODEC	The Compressor-Decompressor (CODEC) encodes and decodes digital audio data on the system.
CompactFlash®	CompactFlash® is a solid-state storage device. CompactFlash® devices use flash memory in a standard size enclosure. Type II is thicker than Type I, but a Type II slot can support both types.
CMOS	Complimentary metal-oxide-conductor is an integrated circuit used in chips like static RAM and microprocessors.
COM	COM refers to serial ports. Serial ports offer serial communication to expansion devices. The serial port on a personal computer is usually a male DB-9 connector.
DAC	The Digital-to-Analog Converter (DAC) converts digital signals to analog signals.
DDR	Double Data Rate refers to a data bus transferring data on both the rising and falling edges of the clock signal.

DMA	Direct Memory Access (DMA) enables some peripheral devices to bypass the system processor and communicate directly with the system memory.
DIMM	Dual Inline Memory Modules are a type of RAM that offer a 64-bit data bus and have separate electrical contacts on each side of the module.
DIO	The digital inputs and digital outputs are general control signals that control the on/off circuit of external devices or TTL devices. Data can be read or written to the selected address to enable the DIO functions.
EHCI	The Enhanced Host Controller Interface (EHCI) specification is a register-level interface description for USB 2.0 Host Controllers.
EIDE	Enhanced IDE (EIDE) is a newer IDE interface standard that has data transfer rates between 4.0 MBps and 16.6 MBps.
EIST	Enhanced Intel® SpeedStep Technology (EIST) allows users to modify the power consumption levels and processor performance through application software. The application software changes the bus-to-core frequency ratio and the processor core voltage.
FSB	The Front Side Bus (FSB) is the bi-directional communication channel between the processor and the Northbridge chipset.
GbE	Gigabit Ethernet (GbE) is an Ethernet version that transfers data at 1.0 Gbps and complies with the IEEE 802.3-2005 standard.
GPIO	General purpose input
HDD	Hard disk drive (HDD) is a type of magnetic, non-volatile computer storage device that stores digitally encoded data.
ICH	The Input/Output Control Hub (ICH) is an Intel® Southbridge chipset.
IrDA	Infrared Data Association (IrDA) specify infrared data transmission protocols used to enable electronic devices to wirelessly communicate with each other.
L1 Cache	The Level 1 Cache (L1 Cache) is a small memory cache built into the system processor.
L2 Cache	The Level 2 Cache (L2 Cache) is an external processor memory cache.

AFL-W19A/W19B/17D/W15A-N270 Panel PC

LCD	Liquid crystal display (LCD) is a flat, low-power display device that consists of two polarizing plates with a liquid crystal panel in between.
LVDS	Low-voltage differential signaling (LVDS) is a dual-wire, high-speed differential electrical signaling system commonly used to connect LCD displays to a computer.
POST	The Power-on Self Test (POST) is the pre-boot actions the system performs when the system is turned-on.
RAM	Random Access Memory (RAM) is volatile memory that loses data when power is lost. RAM has very fast data transfer rates compared to other storage like hard drives.
SATA	Serial ATA (SATA) is a serial communications bus designed for data transfers between storage devices and the computer chipsets. The SATA bus has transfer speeds up to 1.5 Gbps and the SATA II bus has data transfer speeds of up to 3.0 Gbps.
S.M.A.R.T	Self Monitoring Analysis and Reporting Technology (S.M.A.R.T) refers to automatic status checking technology implemented on hard disk drives.
UART	Universal Asynchronous Receiver-transmitter (UART) is responsible for asynchronous communications on the system and manages the system's serial communication (COM) ports.
UHCI	The Universal Host Controller Interface (UHCI) specification is a register-level interface description for USB 1.1 Host Controllers.
USB	The Universal Serial Bus (USB) is an external bus standard for interfacing devices. USB 1.1 supports 12Mbps data transfer rates and USB 2.0 supports 480Mbps data transfer rates.
VGA	The Video Graphics Array (VGA) is a graphics display system developed by IBM.



Appendix

D

Watchdog Timer



NOTE:

The following discussion applies to DOS environment. IEI support is contacted or the IEI website visited for specific drivers for more sophisticated operating systems, e.g., Windows and Linux.

The Watchdog Timer is provided to ensure that standalone systems can always recover from catastrophic conditions that cause the CPU to crash. This condition may have occurred by external EMIs or a software bug. When the CPU stops working correctly, Watchdog Timer either performs a hardware reset (cold boot) or a Non-Maskable Interrupt (NMI) to bring the system back to a known state.

A BIOS function call (INT 15H) is used to control the Watchdog Timer.

INT 15H:

AH – 6FH Sub-function:	
AL – 2:	Sets the Watchdog Timer's period.
BL:	Time-out value (Its unit-second is dependent on the item "Watchdog Timer unit select" in CMOS setup).

Table D-1: AH-6FH Sub-function

Call sub-function 2 to set the time-out period of Watchdog Timer first. If the time-out value is not zero, the Watchdog Timer starts counting down. When the timer value reaches zero, the system resets. To ensure that this reset condition does not occur, calling sub-function 2 must periodically refresh the Watchdog Timer. However, the watchdog timer is disabled if the time-out value is set to zero.

A tolerance of at least 10% must be maintained to avoid unknown routines within the operating system (DOS), such as disk I/O that can be very time-consuming.

NOTE:

When exiting a program it is necessary to disable the Watchdog Timer, otherwise the system resets.

Example program:

```
; INITIAL TIMER PERIOD COUNTER
```

```
;
```

```
W_LOOP:
```

```

MOV    AX, 6F02H    ;setting the time-out value
MOV    BL, 30      ;time-out value is 48 seconds
INT    15H

```

```
;
```

```
; ADD THE APPLICATION PROGRAM HERE
```

```
;
```

```

CMP    EXIT_AP, 1   ;is the application over?
JNE    W_LOOP      ;No, restart the application

```

```

MOV    AX, 6F02H   ;disable Watchdog Timer
MOV    BL, 0       ;
INT    15H

```

```
;
```

```
; EXIT ;
```

Appendix

E

Hazardous Materials Disclosure

E.1 Hazardous Materials Disclosure Table for IPB Products Certified as RoHS Compliant Under 2002/95/EC Without Mercury

The details provided in this appendix are to ensure that the product is compliant with the Peoples Republic of China (China) RoHS standards. The table below acknowledges the presences of small quantities of certain materials in the product, and is applicable to China RoHS only.

A label will be placed on each product to indicate the estimated “Environmentally Friendly Use Period” (EFUP). This is an estimate of the number of years that these substances would “not leak out or undergo abrupt change.” This product may contain replaceable sub-assemblies/components which have a shorter EFUP such as batteries and lamps. These components will be separately marked.

Please refer to the table on the next page.

AFL-W19A/W19B/17D/W15A-N270 Panel PC

Part Name	Toxic or Hazardous Substances and Elements					
	Lead (Pb)	Mercury (Hg)	Cadmium (Cd)	Hexavalent Chromium (CR(VI))	Polybrominated Biphenyls (PBB)	Polybrominated Diphenyl Ethers (PBDE)
Housing	X	O	O	O	O	X
Display	X	O	O	O	O	X
Printed Circuit Board	X	O	O	O	O	X
Metal Fasteners	X	O	O	O	O	O
Cable Assembly	X	O	O	O	O	X
Fan Assembly	X	O	O	O	O	X
Power Supply Assemblies	X	O	O	O	O	X
Battery	O	O	O	O	O	O

O: This toxic or hazardous substance is contained in all of the homogeneous materials for the part is below the limit requirement in SJ/T11363-2006

X: This toxic or hazardous substance is contained in at least one of the homogeneous materials for this part is above the limit requirement in SJ/T11363-2006

此附件旨在确保本产品符合中国 RoHS 标准。以下表格标示此产品中某有毒物质的含量符合中国 RoHS 标准规定的限量要求。

本产品上会附有“环境友好使用期限”的标签，此期限是估算这些物质“不会有泄漏或突变”的年限。本产品可能包含有较短的环境友好使用期限的可替换元件，像是电池或灯管，这些元件将会单独标示出来。

部件名称	有毒有害物质或元素					
	铅 (Pb)	汞 (Hg)	镉 (Cd)	六价铬 (CR(VI))	多溴联苯 (PBB)	多溴二苯醚 (PBDE)
壳体	X	O	O	O	O	X
显示	X	O	O	O	O	X
印刷电路板	X	O	O	O	O	X
金属螺帽	X	O	O	O	O	O
电缆组装	X	O	O	O	O	X
风扇组装	X	O	O	O	O	X
电力供应组装	X	O	O	O	O	X
电池	O	O	O	O	O	O

O: 表示该有毒有害物质在该部件所有物质材料中的含量均在 SJ/T11363-2006 标准规定的限量要求以下。
X: 表示该有毒有害物质至少在该部件的某一均质材料中的含量超出 SJ/T11363-2006 标准规定的限量要求。