



ZIRCON-MM



ZIRCON-MM is our entry-level PC/104 module for basic analog I/O applications that don't require high resolution. The 8-bit A/D and D/A converters are adequate for many price-sensitive applications. This cost-effective module offers high-speed (up to 40,000 samples/second using interrupts) A/D conversions, 24 digital I/O lines, optional counter/timer for A/D conversion timing, external A/D trigger capability, and calibration-free operation.

Two Models to Choose From

The basic Zircon-MM-LC has 8 single-ended 8-bit analog inputs, 1 8-bit analog output, unipolar (0-2.5V and 0-1.25V) input and output ranges, and 24 digital I/O lines.

The full featured Zircon-MM-DX adds many additional features: A clock oscillator and counter/timer chip for interrupt-based A/D conversions and general-purpose counting and timing operations, bipolar input and output ranges, and increased full-scale input swing of 0-5V in unipolar mode and $\pm 5V$ in bipolar mode.

Low Price, High Quality

At Diamond Systems, low price doesn't mean low quality. Zircon-MM still has a 4-layer circuit board with split analog and digital power and ground planes to minimize the effects of digital noise on the analog circuitry. And all versions require only +5V for operation, to help keep total system costs down.

A/D Trigger & Data Transfer

A/D conversions can be triggered in one of three ways. On all models, conversions can be triggered with a software command or with an external hardware trigger signal. On the DX model, the counter/timer can also be used for automatic timed conversions.

With software triggering, the software reads the A/D converter value when the conversion is complete, whereas with both external and counter/timer triggering methods, the A/D data is transferred to memory automatically using interrupts.

Counter Timer Features

The DX model has an on-board 4MHz clock oscillator and an 82C54 3-channel counter/timer IC. This enables you to program the A/D conversion rate and have the board perform conversions automatically, transferring the data to system memory using interrupts.

Two counter/timers are combined to provide the A/D timer, and the third counter/timer is available on the I/O header for general purpose use.

82C55 Digital I/O IC

Zircon-MM provides 24 digital I/O lines using an 82C55 IC. All lines contain 10K Ω pull-up resistors, and the directions of all lines are programmable in 4- and 8-bit groups. A complete datasheet for this part is included in the user manual, and you may also download the datasheet from our website.

FEATURES

Basic features, BOTH versions

- ◆ 8 single-ended analog inputs, 8-bit resolution
- ◆ 0 - 2.5V, 0 - 1.25V analog input ranges
- ◆ 1 analog output, 8-bit resolution
- ◆ 0 - 2.5V, 0 - 1.25V analog output ranges
- ◆ 24 digital I/O lines (82C55)
- ◆ 40,000 samples/second A/D throughput
- ◆ Requires only +5 power supply
- ◆ Software and manual included

Additional Features, DX version

- ◆ 32-bit counter/timer for A/D conversion timing
- ◆ 16-bit counter/timer for general purpose use
- ◆ 4MHz on-board clock oscillator to drive counter/timers
- ◆ 0 - 5V, $\pm 5V$, $\pm 2.5V$, $\pm 1.25V$ analog input ranges
- ◆ $\pm 2.5V$, $\pm 1.25V$ analog output ranges

FREE SOFTWARE

See Page 49 for Details



Tri-M Systems & Engineering

Unit 100, 1407 Kebet Way, Port Coquitlam, BC V3C 6L3, Canada
 Phone: 604.945.9565 or toll free: 800.665.5600 Fax: 604.945.9566
 Email: info@tri-m.com Web: www.tri-m.com



ANALOG I/O RANGES

Input range	Resolution	Model
0 - 1.25V	4.9mV	LC, DX
0 - 2.5V	9.8mV	LC, DX
0 - 5V	19.5mV	DX only
±1.25V	9.8mV	DX only
±2.5V	19.5mV	DX only
±5V	39.1mV	DX only
Output range	Resolution	Model
0 - 1.25V	4.9mV	LC, DX
0 - 2.5V	9.8mV	LC, DX
±1.25V	9.8mV	DX only
±2.5V	19.5mV	DX only

I/O HEADER

VIN 7	1	2	VIN 6
VIN 5	3	4	VIN 4
VIN 3	5	6	VIN 2
VIN 1	7	8	VIN 0
ANALOG GND	9	10	ANALOG GND
VOUT	11	12	ANALOG GND
ANALOG GND	13	14	ANALOG GND
+5V OUTPUT	15	16	-5V OUTPUT (DX only)
ANALOG GND	17	18	ANALOG GND
ANALOG GND	19	20	EXT TRIGGER
GATE 1&2	21	22	CLK 0
GATE 0	23	24	OUT 0
A7	25	26	A6
A5	27	28	A4
A3	29	30	A2
A1	31	32	A0
C7	33	34	C6
C5	35	36	C4
C3	37	38	C2
C1	39	40	C0
B7	41	42	B6
B5	43	44	B4
B3	45	46	B2
B1	47	48	B0
+5V	49	50	DIGITAL GND

SPECIFICATIONS

Analog Inputs	
No. / type of channels	8 single-ended
Resolution	8 bits (1 part in 256)
A/D conversion time	2.6 µs max
Max. conversion rate	40 kHz typical, interrupt-based single conversions; 40 kHz, single channel; 64 kHz typical, interrupt-based 8-channel scan
Relative accuracy	±1 LSB max
Offset error	±3 LSB max
Full-scale error	-4, +0 LSB max
Input current	LC, DX LC: ±300 µA max DX: ±25 µA max
Analog Outputs	
No. / type of channels	1, voltage output
Resolution	8 bits (1 part in 256)
Settling time	4 µs max to ±1/2 LSB
Offset error	±2 LSB max
Full-scale error	±2 LSB max
Digital I/O	
Number of lines	24 (using 82C55 chip)
Direction groups	Programmable in 4/8 bit groups
Compatibility	TTL / CMOS
Pull-up resistors	10KΩ on each I/O line
Output current	±2.5mA max per line
Counter/Timers (DX only)	
No. of counter/timers	3, 16-bit
Compatibility	TTL / CMOS
Max. input frequency	10MHz
On-board oscillator	4MHz
Configuration	Counters 1 and 2 cascaded for interrupts; Counter 0 free
General	
Dimensions	3.55" x 3.775" (PC/104 standard)
Operating temperature	0 to 70°C Standard, -40 to +85°C Extended
Power supply	+5VDC ±10%
Current consumption	(typical, all outputs open) ZMM-DX 127mA ZMM-LC 100mA
Weight	ZMM-LC: 2.7oz / 76g ZMM-DX: 3.0oz / 85g

ZIRCON-MM BLOCK DIAGRAM

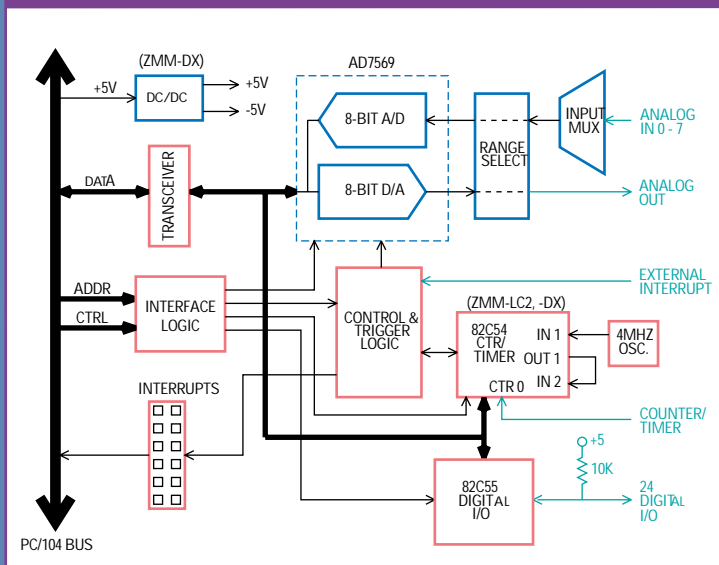

Tri-M Systems & Engineering

Unit 100, 1407 Kebet Way, Port Coquitlam, BC V3C 6L3, Canada
 Phone: 604.945.9565 or toll free: 800.665.5600 Fax: 604.945.9566
 Email: info@tri-m.com Web: www.tri-m.com



ANALOG I/O