

FeaturePak™

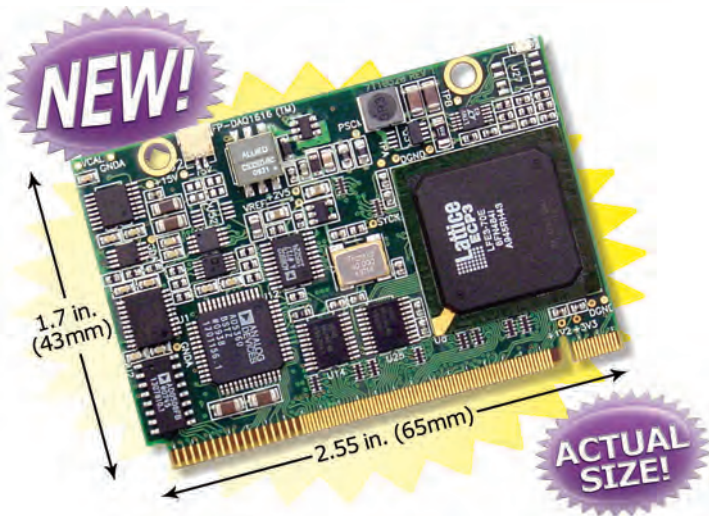

WORLD'S SMALLEST PCI EXPRESS OPEN ARCHITECTURE EMBEDDED I/O STANDARD

Key Features

- ◆ Compact, low profile form-factor—0.6x the size of a credit card!
- ◆ Single low-cost connector integrates all host and external I/O signals
- ◆ Provides up to 100 I/O points per module
- ◆ Leverages industry-standard buses such as PCI Express, USB, and SMBus
- ◆ Host form-factor and processor agnostic
- ◆ Coexists with PC/104, SUMIT, Qseven, ETX, XTX, COM Express, etc.
- ◆ Multiple FeaturePak modules may be present within one system
- ◆ Rugged and reliable
- ◆ Open industry standard

Key Benefits

- ◆ Shortens time-to-market
- ◆ Reduces board-level development costs and risks
- ◆ Simplifies system design
- ◆ Eliminates cables, resulting in higher reliability, lower cost, and faster assembly
- ◆ Enables scalable and reconfigurable system design
- ◆ Enables easy product upgrades
- ◆ Protects from component obsolescence
- ◆ Encapsulates intellectual property
- ◆ Suitable for SBCs, baseboards, and proprietary all-in-one hardware designs
- ◆ Ideal for rapid-prototyping through high-volume applications
- ◆ Ideal format for silicon vendor reference designs
- ◆ Open standard increases market acceptance

FeaturePak is an exciting new embedded system expansion standard, originated by Diamond Systems, that provides a compact, low-cost method of adding I/O to board-level embedded computers. FeaturePak modules can be used as snap-in customization modules for commercial, off-the-shelf single-board computers (SBCs) and computer-on-module (COM) baseboards, or as functional blocks on fully-custom embedded electronics.

This new mezzanine-style embedded I/O expansion standard is highly synergistic with existing and emerging bus-, I/O-, chip- and board-level technologies. It leverages the latest high-speed serial expansion standards—such as PCI Express and USB—and is compatible with a wide range of current and future processors, including both x86 and RISC architectures.

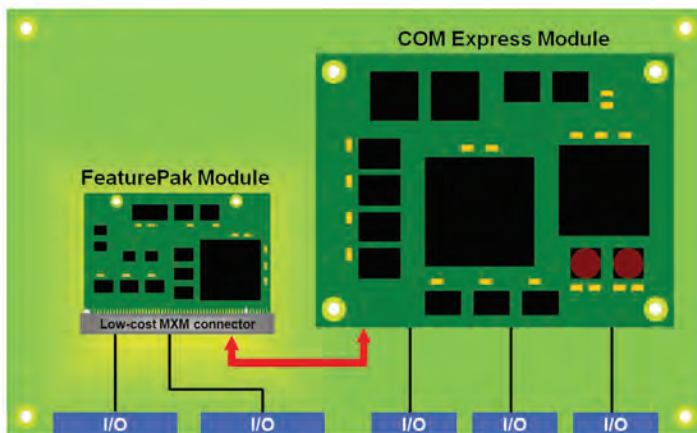

FeaturePak on COM Express baseboard

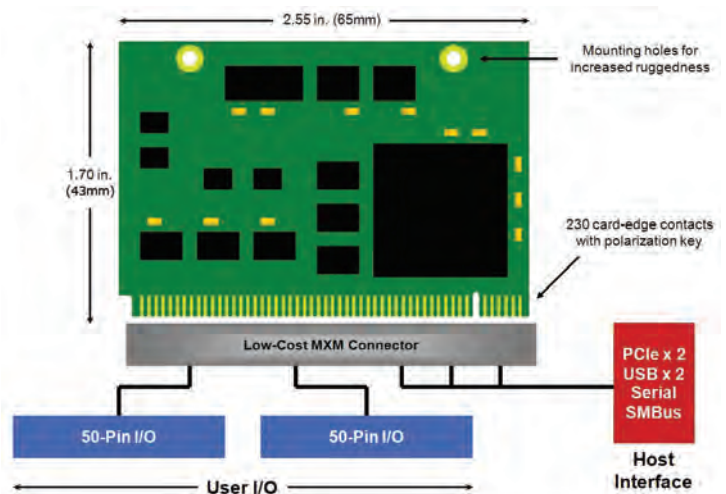

FeaturePak modules Enable Faster and More Flexible Baseboard Design

With their compact size and standardized connector, FeaturePak modules are easy-to-use macrocomponents that target a wide range of embedded applications. Embedded computer design can be greatly simplified by treating complex I/O subsystems as components, just as various types of COMs (computer-on-modules)

allow designers to treat the core embedded computing functions as a plug-in building block. This macrocomponent approach greatly accelerates design cycles, and also enables the creation of reconfigurable and upgradable products.

FEATUREPAK-DAQ1616

NEW!

FeaturePak Analog I/O Module with 2MHz A/D and Autocalibration

- ◆ 16 16-bit analog inputs with 2MHz maximum sampling rate
- ◆ Programmable input ranges, polarity, and mode
- ◆ 16K sample A/D FIFO with programmable threshold
- ◆ 16 16-bit analog outputs with programmable range and polarity
- ◆ Autocalibration circuit with precision reference voltages
- ◆ 56 programmable digital I/O
- ◆ 2 32-bit counter/timers for A/D timing and general purpose use
- ◆ 4 24-bit pulse-width modulator circuits
- ◆ Watchdog timer with system reset capability
- ◆ 1 PCI Express x1 lane host interface
- ◆ FeaturePak form-factor compliant
- ◆ -40°C to +85°C operating temperature
- ◆ Universal Driver software support



FP-DAQ1616 is a FeaturePak I/O card featuring Diamond's newest and fastest analog I/O technology and a PCI Express interface. This board offers 16-bit A/D sampling at 2MHz, supported with an expanded 16K-sample FIFO for reliable data collection in any operating system. Analog output capability has been expanded to 16 16-bit channels with programmable output ranges. All analog I/O features are enhanced with our industry-leading autocalibration technology, featuring independent calibration factors for each input and output range to guarantee maximum accuracy across all operating modes and the entire operating temperature range.

Digital I/O features include 7 8-bit ports with both bit-wide and byte-wide direction control, 2 32-bit up/down counter/timers with programmable input source and gate, 4 24-bit pulse-width modulation circuits with 0-100% duty cycle, and a watchdog timer. Universal Driver software support is included for Linux, Windows XP/Embedded Standard, and Windows CE.

The board is available in analog I/O and analog out-only configurations.

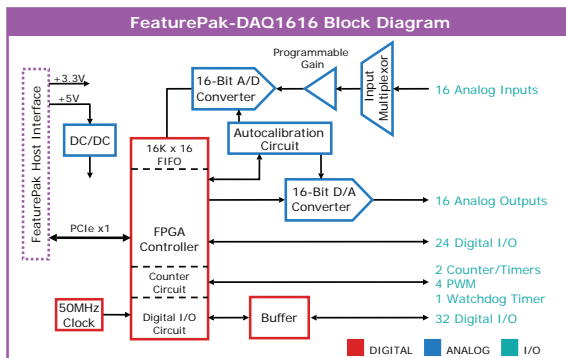

Available Models

FP-DAQ1616	FeaturePak 2MHz 16-Bit Analog I/O and Digital I/O Module
FP-DA16	FeaturePak Analog Output and Digital I/O Module

FEATUREPAK-GPIO96

NEW!

FeaturePak Programmable Digital I/O Module with Customizable Personality

- ◆ FPGA- based design with in-the-field reconfigurability
- ◆ 96 buffered, programmable digital I/O
- ◆ Byte-wide and bit-wide port direction control
- ◆ 3.3V and 5V user-selectable I/O configuration
- ◆ 8 32-bit counter/timers
- ◆ 4 24-bit pulse-width modulators
- ◆ Watchdog timer with system reset capability
- ◆ 50MHz system clock
- ◆ 1 PCI Express x1 lane host interface
- ◆ FeaturePak form-factor compliant
- ◆ -40°C to +85°C operating temperature
- ◆ Universal Driver software support



FP-GPIO96 is a FeaturePak general purpose I/O module using a high-capacity (700K gate equivalent) PCI Express FPGA for maximum density and flexibility. The base hardware configuration features 96 digital I/O lines grouped into 12 8-bit ports. All ports have I/O buffers to protect the FPGA and offer user-selectable 3.3V or 5V logic drive levels. The ports are organized into a combination of byte-wide, nibble-wide, and bit-wide direction control for maximum flexibility and application compatibility.

The built-in FPGA personality provides multiple configuration options. All 96 I/O lines may be used in common I/O mode; Six of these ports can be reconfigured to enable an array of additional features, including 8 32-bit up/down counter/timers with programmable input source and gate, 4 24-bit PWM circuits with 0-100% duty cycle capability, interrupt/latched mode operation, and even a watchdog timer feature.

The flash-based design enables easy field upgrades using a Diamond-provided software utility (no cable or 3rd party software required!) as well as custom code development. Universal Driver software support is included for Linux, Windows XP/Embedded Standard, and Windows CE.

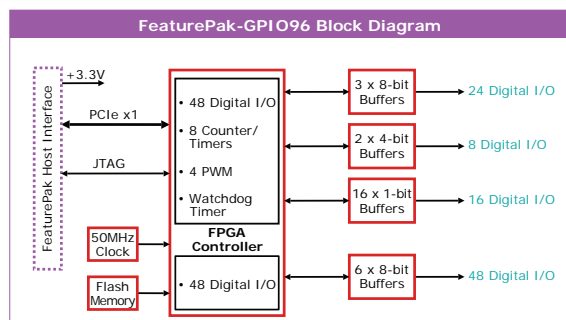

Available Models

FP-GPIO96	FeaturePak Programmable GPIO Module with standard personality
------------------	---