

Table of Contents

Introduction.....	8
Description and Features.....	8
Block Diagram.....	10
Functional Overview.....	11
Board Description.....	14
Connector Summary.....	15
Jumper Summary.....	16
Connectors.....	17
PC/104 ISA Bus.....	17
PC/104-Plus PCI Bus.....	18
PS2 Mouse and Keyboard connector.....	20
Utility Connector.....	20
Data Acquisition (Digital I/O) Connector.....	23
Data Acquisition (Analog I/O) Connector.....	25
Ethernet Connectors.....	26
Audio I/O Connector.....	27
Speaker Connector.....	28
CD Input Connector.....	29
External Auxiliary Power Connector (Output).....	29
Primary IDE Connector.....	30
Secondary IDE Connector.....	31
Serial Port I/O Connector.....	32
External Battery Connector.....	34
USB 1.1 Connectors.....	35
USB1 Connector.....	36
LCD Panel (LVDS Interface) Connector.....	37
VGA Connector.....	38
Video/TV Out Connector.....	38
CPU Fan Connector.....	39
LCD Backlight Connector.....	40
Low-Voltage Power Input Connector.....	40
High-Voltage Power Input Connector (Optional).....	42
CompactFlash Slot (optional).....	43
USB 2.0 Connectors.....	43
Board Configuration.....	44
Jumper Block J4.....	45
Jumper Block J5.....	49
Jumper Block J19 - PCI VIO Voltage Selection.....	52
Jumper 35 - Crisis Recovery.....	53
System Features.....	54

System Resources.....	54
COM Port / FPGA Control Registers.....	54
Console Redirection to a Serial Port.....	55
Watchdog Timer.....	56
Failsafe Mode and BIOS Recovery.....	56
Flash Memory.....	57
Backup Battery.....	57
System Reset.....	57
On-Board Video.....	57
BIOS.....	58
Bios Settings.....	58
BIOS Download / Crisis Recovery.....	59
BIOS COM Port Settings.....	60
BIOS Console Redirection Settings.....	61
System I/O.....	62
Ethernet.....	62
Serial Ports.....	62
PS/2 Ports.....	63
USB Ports.....	64
Notes on Operating Systems and Booting Procedures.....	65
Windows Operating System Installation Issues.....	65
DOS Operating Systems Installation Issues.....	66
CompactFlash Compatibility Issues Under DOS.....	66
Data Acquisition Circuit.....	67
Data Acquisition Circuitry I/O Map.....	68
I/O Register Map Bit Assignments.....	70
I/O Register Definitions.....	73
Data Acquisition Circuit Configuration.....	92
Single-ended/Differential Inputs.....	92
Unipolar/Bipolar Inputs.....	92
Analog Output Configuration.....	92
Analog-to-Digital Input Ranges and Resolution.....	93
Overview.....	93
Input Range Selection.....	93
Input Range Table.....	93
Performing an A/D Conversion.....	93
Select the Input Channel.....	94
Select the Input Range.....	94
Wait for Analog Input Circuit to Settle.....	94
Perform an A/D Conversion on the Current Channel.....	94
Wait for the Conversion to Finish.....	95

Read the Data from the Board.....	95
Convert the numerical data to a meaningful value.....	96
A/D Scan, Interrupt, and FIFO Operation.....	97
Hercules II A/D Operating Modes.....	98
Digital-to-Analog Output Ranges and Resolution.....	100
Description.....	100
Resolution.....	100
Output Range Selection.....	100
D/A Conversion Formulas and Tables.....	100
Generating an Analog Output.....	102
Analog Circuit Calibration Resources.....	104
Analog Circuit Calibration Procedures.....	105
Using EEPROM.....	106
Reading Value from EEPROM.....	106
Writing Value to EEPROM.....	106
Digital I/O Operation.....	107
Special Digital I/O Operation – Port E.....	108
DIO Handshaking Operation.....	108
DIO Pull-up/Down Settings.....	109
Counter/Timer Operation.....	111
Counter 0 – A/D Sample Control.....	111
Counter 1 – Counting/Totalizing Functions.....	111
Command Sequences.....	111
Pulse Width Modulation Operation.....	115
Pulse-Width Modulation Example.....	116
Watchdog Timer Programming.....	118
Example: Watchdog Timer With Software Trigger.....	118
Example: Watchdog Timer With Hardware Trigger.....	118
Data Acquisition Specifications (Data Acquisition units only).....	119
Analog Inputs.....	119
Analog Outputs.....	119
Digital I/O.....	119
Counter/Timers.....	119
General.....	119
FlashDisk Module.....	120
Installing the FlashDisk Module.....	120
Using the FlashDisk with Another IDE Drive.....	120
Power Supply.....	121
Utility Board.....	122

Data Acquisition Test Board.....	123
Connecting the DAQ Test Board.....	123
DAQ Board DIO interface.....	124
DIO A – DIO B Loopback.....	124
DIO C – DIO D – DIOE Loopback.....	124
Special Functions.....	125
DAQ Board Analog Testing.....	126
FlashDisk Programmer Board.....	128
I/O Cables.....	129
Mounting PC/104(+) Cards onto a Hercules II EBX Baseboard.....	131
CompactFlash.....	132
Customization Options.....	133
Specifications.....	134
CPU.....	134
Data Acquisition Circuitry.....	134
Power Supply.....	134
General.....	134
Additional Information.....	135
Appendix A - Hercules and Hercules II Differences.....	136
Technical Support.....	137

Figures

Figure 1: Hercules II-EBX Functional Block Diagram.....	10
Figure 2: Hercules II EBX Board Layout.....	14
Figure 3: J1 and J2 Connectors.....	17
Figure 4: J3 Connector.....	18
Figure 5: J6 Connector.....	20
Figure 6: J7 Connector.....	20
Figure 7: J8 Connector.....	23
Figure 8: J9 Connector.....	25
Figure 9: J10 and J11 Connectors.....	26
Figure 10: J12 Connector.....	27
Figure 11: J13 Connector.....	28
Figure 12: J14 Connector.....	29
Figure 13: J15 Connector.....	29
Figure 14: J16 Connector.....	30
Figure 15: J17 Connector.....	31
Figure 16: J18 Connector.....	32
Figure 17: J20 Connector.....	34
Figure 18: J21 and J22 Connectors.....	35
Figure 19: J23 Connector.....	36
Figure 20: J25 Connector.....	38
Figure 21: J26 Connector.....	38
Figure 22: J27 Connector.....	39
Figure 23: J28 Connector.....	40
Figure 24: J29 Connector.....	40

Figure 25: J30 Connector.....	42
Figure 26: J36 and J37 Connectors.....	43
Figure 27: Jumper Block J4 Default Settings.....	45
Figure 28: J4 COM3/COM4 IRQ Selection Examples.....	46
Figure 29: A/D IRQ Selection Examples.....	47
Figure 30: ATX Power Control Jumper.....	47
Figure 31: CMOS RAM Erase Jumper.....	48
Figure 32: COM3 and COM4 RS485 Termination Jumpers.....	48
Figure 33: COM3 and COM4 RS422 Termination Jumpers.....	49
Figure 34: Jumper Block J5 Default Settings.....	49
Figure 35: COM3/COM4 I/O Address Selection.....	50
Figure 36: CompactFlash Master/Slave Selection Jumper.....	51
Figure 37: DIO Pull-up/Pull-down Selection Jumpers.....	51
Figure 38: Jumper Block J19.....	52
Figure 39: J19 Voltage Selection.....	53
Figure 40: Watchdog Timer Block Diagram.....	56
Figure 41: Data Acquisition Block Diagram.....	67
Figure 42: DIOLATCH/ACK Handshaking Sequence.....	109
Figure 43: Flashdisk Module.....	120
Figure 44: Utility Board.....	122
Figure 45: Data Acquisition Test Board.....	123
Figure 46: FlashDisk Programmer Board Layout.....	128
Figure 47: Cable Kit.....	130
Figure 48: Differences Between Hercules and Hercules II Boards.....	136

Introduction

Hercules II is an embedded CPU board in an EBX form factor that integrates the following subsystems onto a single compact board:

- CPU
- Core PC Chipset (including memory controller, PCI interface, and ISA interface)
- Video
- Sound
- Ethernet
- Analog and digital I/O

Hercules II EBX conforms to the EBX standard with expansion support via *PC/104-Plus*, an embedded standard that is based on the ISA and PCI buses and provides a compact, rugged mechanical design for embedded systems. PC/104 modules feature a pin and socket connection system in place of card edge connectors, as well as mounting holes for stand-offs in each corner. The result is an extremely rugged computer system fit for mobile and miniature applications. PC/104 modules stack together with 0.6" spacing between boards (0.662" pitch including the thickness of the PCB).

Hercules II EBX uses the PCI bus internally to connect the Ethernet circuit to the processor. It uses the ISA bus internally to connect serial ports 3 and 4, as well as the data acquisition circuit, to the processor. Both the ISA and PCI buses are brought out to expansion connectors for the connection of add-on boards. Diamond Systems manufactures a wide variety of compatible PC/104 add-on boards for analog I/O, digital I/O, counter/timer functions, serial ports, and power supplies.

This manual includes:

- An introduction to the Hercules II EBX.
- Board connectors.
- Configuration information.
- A description of each of the board subsystems and their usage.
- Board specifications.
- Additional resource information.

Description and Features

The Hercules II EBX is an upgrade to the existing Diamond Systems Corporation Hercules product. The board is an all-in-one embedded CPU with the following key system and data acquisition features.

Processor Section

- Pentium-3 class Via Mark Integrated Processor and North Bridge.
- 265/512MB SDRAM system memory, depending on configuration.
- 100MHz memory bus.
- 2MB 16-bit wide integrated flash memory for BIOS and user programs.
- 2D & 3D VGA Video graphics engine (VESA-style VGA output with DDC Monitor support)
- 33MHz PCI Bus.

I/O Section

- 4 serial ports, 115.2kbaud max.
 - 2 ports 16550-compatible
 - 2 ports 16850-compatible with 128-byte FIFOs and RS232, RS422 and RS485 capability
- 4 USB 1.1 ports.
- 4 USB 2.0 ports.
- 2 IDE drive connectors (standard 40-pin IDE and 44-pin version for notebook drives).
- Accepts solid-state flash disk modules directly on board.

- 10/100 BaseT full-duplex PCI bus mastering Ethernet (100Mbps and 10Mbps).
- IrDA port (requires external transceiver).
- PS/2 keyboard and mouse ports
- LEDs.
- Interface for speaker and additional external LEDs.

Analog Input

- 32 single-ended / 16 differential inputs, 16-bit resolution
- 250KHz maximum aggregate A/D sampling rate
- Programmable input ranges/gains with maximum range of $\pm 10V$ / 0-10V
- Both bipolar and unipolar input ranges
- 5 ppm/ $^{\circ}C$ drift accuracy
- Internal and external A/D triggering
- 2048-sample FIFO for reliable high-speed sampling and scan operation

Analog Output

- 4 analog outputs, 12-bit resolution
- $\pm 10V$ and 0-10V output ranges
- Simultaneous update
- Adjustable output range (optional)

Digital I/O

- 40 programmable digital I/O, 3.3V and 5V logic compatible
- Enhanced output current capability: -8/+12mA max
- Selectable pull-up/down resistors on board

Counter/Timers

- 1 24-bit counter/timer for A/D sampling rate control
- 1 16-bit counter/timer for user counting and timing functions
- Programmable gate and count enable
- Internal and external clocking capability
- 4 programmable pulse width modulation signals with 0 to 100% duty cycle capability

System Features

- Plug and play BIOS with IDE auto detection, 32-bit IDE access, and LBA support.
- One CompactFlash socket.
- Built-in fail-safe boot ROM for system recovery in case of BIOS corruption.
- User-selectable COM1 or COM2 terminal mode.
- On-board lithium backup battery for real-time-clock and CMOS RAM.
- ATX power switching capability.
- Programmable watchdog timer
- Wide input (5VDC – 28VDC) power supply – Jumper select for 5VDC operation from the PC-104 bus.
- Extended temperature range operation (-40 to +85 $^{\circ}C$).

Block Diagram

Figure 1 shows the Hercules II EBX functional blocks.

Figure 1: Hercules II-EBX Functional Block Diagram

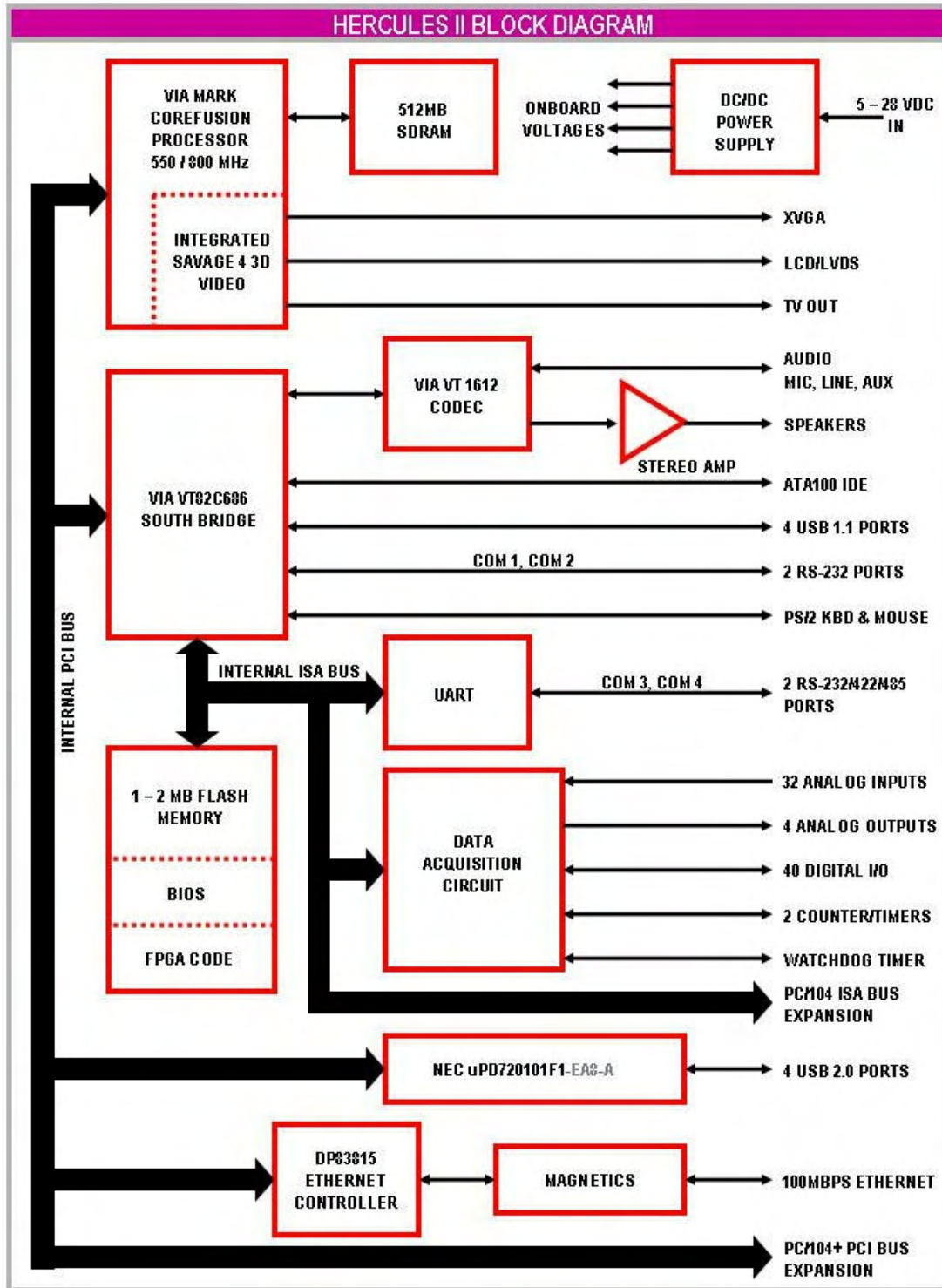

Functional Overview

This section describes the major Hercules II EBX subsystems.

Processor and North Bridge

Hercules II EBX uses the Via Mark Corefusion™ Processor, operating at a frequency of 800MHz. The North Bridge is integrated in the Via Mark, providing single chip CPU, memory controller and video/LCD/graphics features .

Hercules II EBX operates with a passive heatsink at the 85°C maximum operating temperature.

South Bridge

The South Bridge chip is the Via VT82C686B. This chip provides standard peripherals of,

- two serial ports
- four USB 1.1 ports
- PS/2 keyboard
- mouse

The South Bridge chip also generates the ISA bus for use on and off the board.

Memory

The board accommodates either 265MB, or 512MB, of SDRAM system memory, depending on configuration, soldered on the board. No expansion connector is provided for additional memory.

The board also includes flash memory for storage of BIOS and user programs. Flash memory is accessible via the on-board ISA bus.

Video Features

The video circuit consists of a Savage 4 2D/3D video accelerator with internal 128-bit 2D and 3D architecture integrated into the North Bridge chip. It shares up to a 32MB buffer (Unified Memory Architecture) with system memory, so dedicated video memory chips are not required. Video features include both CRT and LCD support. MPEG-2 motion compensation is built-in to aid MPEG/DVD decompression.

Video features also include the following.

- An 18-bit, two-channel LVDS hardware interface as an interface to LCD displays.
- CRT resolution of up to 1920 x 1440.
- Simultaneous CRT and LCD support.
- TV output signals.

Audio

The design provides AC97 audio support derived from the South Bridge chip. The Via VT1612A CODEC provides audio processing. Give special attention to design and routing to minimize noise on the audio I/O lines.

Audio I/O includes,

- Stereo line in.
- Stereo line out.
- Mono mic in.
- Stereo internal line in.

The board includes audio power amplifier circuitry for stereo speaker output. The amplifier circuit is powered by +5VDC from the board. User DC control of volume is also provided, which overrides the software settings.

Ethernet

The board uses the National Semiconductor DP83815 chip on the internal PCI bus for 10/100Mbps Ethernet. Magnetics are included on the board so that a complete circuit is provided. Wake-On-LAN feature is supported. However, implementation of Wake-On-LAN requires integration with the board's power supply and possible BIOS extensions.

Data Acquisition

The board provides the following data acquisition capabilities.

<i>Type of I/O</i>	<i>Characteristics</i>
Analog Input	32 single-ended/16 differential inputs, 16-bit resolution
Analog Output	Four analog outputs, 12-bit resolution
Digital I/O	40 programmable digital I/O, 3.3V and 5V logic compatible
Counter/Timers	One 24-bit counter/timer for A/D sampling rate control One 16-bit counter/timer for user counting and timing functions

Standard Peripherals

The board provides the following standard system peripherals.

<i>Peripheral</i>	<i>Characteristics</i>
Serial ports	Four serial ports
PS/2 ports	Keyboard and mouse
USB ports	Four USB 1.1 function ports and four USB 2.0 function ports
IrDA	One IrDA 1.0
IDE ports	One 44-pin connector for FlashDisk One 40-pin dual-channel UDMA-100 Compact flash socket

Serial ports 1 and 2 are derived from the South Bridge chip. Serial ports 3 and 4 are derived from an Exar 16C2850 UART chip on the ISA bus.

Serial ports 3 and 4 also can be BIOS-selected for RS-485 or RS-232. These settings can be overridden by a jumper to select RS422. Termination resistors of 120 ohms can be jumper-enabled on these two ports.

Console redirection feature is incorporated. This feature enables keyboard input and character video output to be routed to one of the serial ports.

The board contains provision for mounting a solid state IDE flashdisk module with capacities ranging from 32MB and greater. The module mounts onto the board using a 44-pin 2mm pitch header and a hold-down mounting hole with spacer and screws.

A compact flash socket is attached to the bottom of the PCBA.

Bus Interfaces

The PCI bus is the primary connection between the North Bridge, South Bridge, Ethernet, and PC/104-*Plus* devices.

The ISA bus is exposed on PC/104 connectors for use by add-on modules. The PC/104 connectors allow expansion above the board only.

Power Supply

The power supply is an on-board converter, allowing an input range of 5 to 28VDC. Jumper selection allows power to be taken from the PC-104 bus and not from the on-board converter.

The power supply includes ATX power switching and ACPI power management support. The master +5V input is controlled by the ATX function with an external switch input.

Battery Backup

The board includes a backup battery for CMOS RAM and real-time clock backup. The battery life is greater than four years. A connector and jumper are provided to disable the on-board battery and enable the use of an external battery, instead.

Watchdog Timer

A watchdog timer (WDT) circuit consists of two cascaded programmable timers, which may be triggered in hardware or software.

Configurations

Hercules II EBX is available in two standard configurations. (Custom configurations and ruggedization services are also available).

<i>Model</i>	<i>Description</i>
HRC800-5A512	800MHz processor, 512MB DRAM, full data acquisition
HRC800-5N256	800MHz processor, 256MB DRAM, digital I/O

Board Description

Board Layout

Figure 2 shows the Hercules II EBX board layout, including connectors, jumper blocks and mounting holes.

Figure 2: Hercules II EBX Board Layout

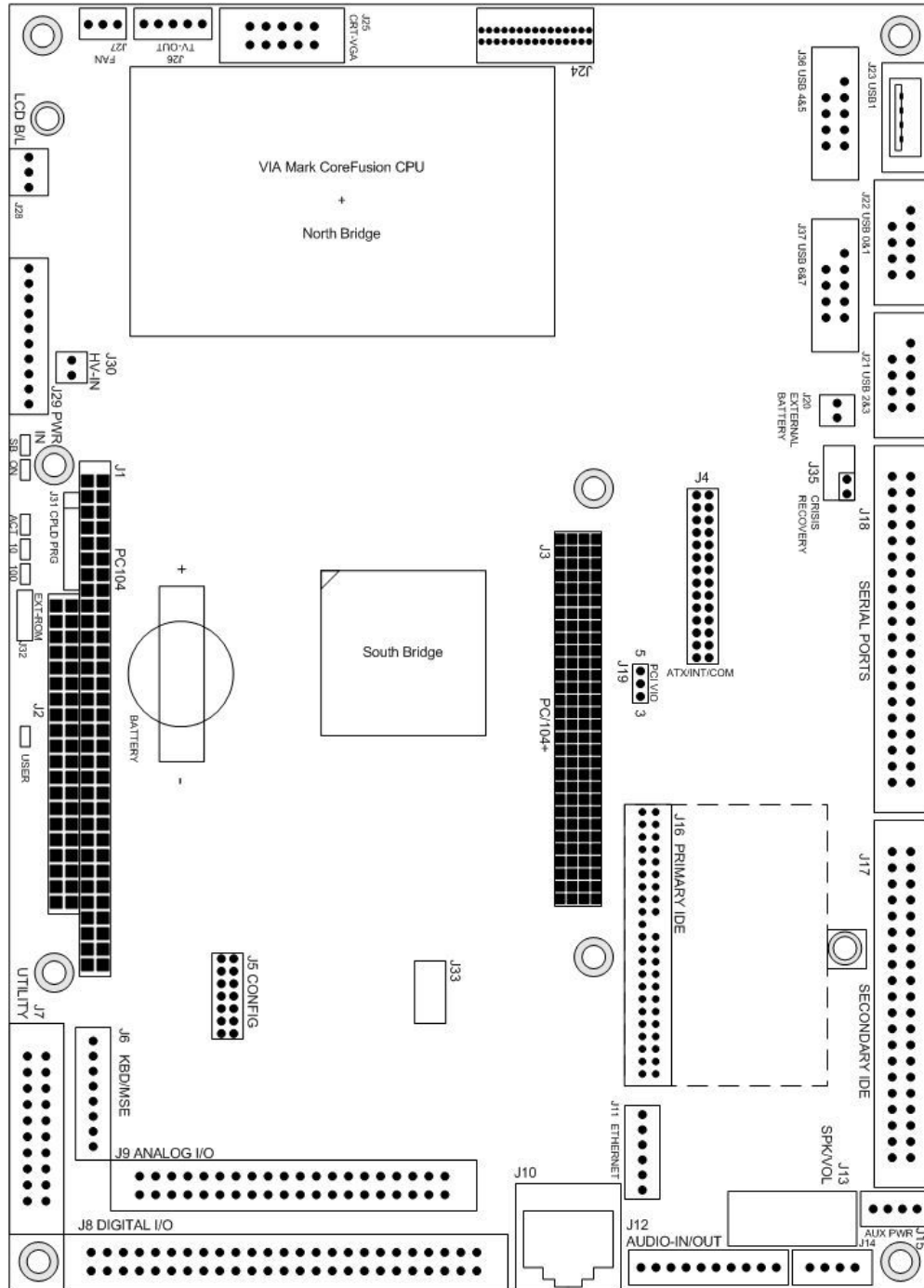

Connector Summary

The following table lists the connectors on the Hercules II EBX board.

Connector	Description	Manufacturer Part No.
J1	PC/104, ISA bus A,B	EPT 962-60323-12
J2	PC/104, ISA bus C,D	EPT 962-60203-12
J3	PC/104- <i>Plus</i> PCI bus connector	-
J6	PS/2 Mouse and keyboard	Digikey 640456-8
J7	Standard button/LED utility connector	Phyco 2120-20S
J8	Data acquisition digital I/O, 50-pin	Phyco 2120-50S
J9	Data acquisition analog I/O, 40-pin	Phyco 2120-40S
J10	RJ-45 Ethernet	Capsco Sales, Inc. GD-PNS-88
J11	Ethernet header	Digikey 640456-6
J12	Audio I/O	Digikey A1925
J13	Speaker	Standard 2x5, 0.1" Box header
J14	CD Input	Molex 70543-0003
J15	External auxiliary power (output)	Digikey 640456-4
J16	Primary IDE	All American Semiconductor 2115-2X22GDP/PPTB
J17	Secondary IDE	Phyco 2120-40S (with pin 20 removed)
J18	RS232/RS485/RS422 serial I/O	Phyco 2120-40S
J20	External battery	Digikey A1921
J21	USB 2/3 (USB 1.1)	Standard 2x5, 0.1" header (with pin 1 removed)
J22	USB 0/1 (USB 1.1)	Standard 2x5, 0.1" header (with pin 1 removed)
J23	USB1 (USB 1.1)	Capsco Sales, Inc. KUSB-AS-1-N-WHT
J24	LCD panel (LVDS interface)	JST Part No.: BM30B-SRDS-G-TF
J25	VGA	Standard 2x5, 0.1" Box header
J26	Video/TV out	Digikey 640456-5
J27	CPU fan	Heilind Electronics 89400-0320
J28	LCD backlight	Digikey A19470
J29	Low-voltage power input	Digikey A1925
J30	High-voltage power input (optional)	Digikey A1921
J34	CompactFlash slot (on bottom of board)	-
J36	USB 4/5 (USB 2.0)	Standard 2x5, 0.1" header (with pin 1 removed)
J37	USB 6/7 (USB 2.0)	Standard 2x5, 0.1" header (with pin 1 removed)

Jumper Summary

The following table lists the jumpers on the board.

<i>Jumper</i>	<i>Description</i>
J4	Serial port and A/D IRQ settings ATX power control Erasing CMOS RAM RS-485 termination settings RS-422 termination and selection
J5	Serial port address setting CompactFlash IDE control Write-protect BIOS flash DIO pull-up/pull-down selections
J19	PCI VI/O voltage selection
J35	Crisis recovery

Connectors

This section describes the connectors on the Hercules II EBX board.

Note: All cables mentioned in this section are included in Diamond Systems Corporation cable kit C-HRCEBX-KIT. Some cables are also available individually.

PC/104 ISA Bus

Connectors J1 and J2 carry the ISA bus signals. Figure 3 shows the PC/104 A and B pin layout for J1, and the C and D pin layout for J2.

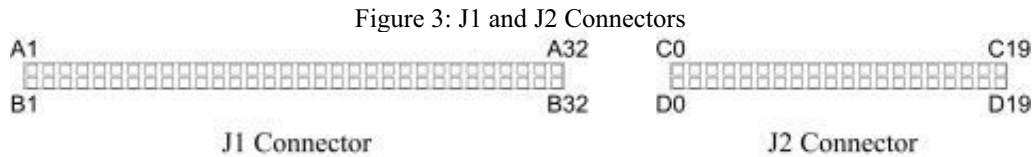

<i>J1 Connector Pinout</i>			
IOCHCHK-	A1	B1	GND
SD7	A2	B2	RESETDRV
SD6	A3	B3	+5V
SD5	A4	B4	IRQ9
SD4	A5	B5	-5V
SD3	A6	B6	DRQ2
SD2	A7	B7	-12V
SD1	A8	B8	ENDXFR-
SD0	A9	B9	+12V
IOCHRDY	A10	B10	keyed
AEN	A11	B11	SMEMW-
SA19	A12	B12	SMEMR-
SA18	A13	B13	IOW-
SA17	A14	B14	IOR-
SA16	A15	B15	DACK3-
SA15	A16	B16	DRQ3
SA14	A17	B17	DACK1-
SA13	A18	B18	DRQ1
SA12	A19	B19	REFRESH-
SA11	A20	B20	SYSCLK
SA10	A21	B21	IRQ7
SA9	A22	B22	IRQ6
SA8	A23	B23	IRQ5
SA7	A24	B24	IRQ4
SA6	A25	B25	IRQ3
SA5	A26	B26	DACK2-
SA4	A27	B27	TC
SA3	A28	B28	BALE
SA2	A29	B29	+5V
SA1	A30	B30	OSC
SA0	A31	B31	GND
GND	A32	B32	GND

<i>J2 Connector Pinout</i>			
GND	D0	D0	GND
SBHE-	D1	D1	MEMCS16--
LA23	D2	D2	IOCS16-
LA22	D3	D3	IRQ10
LA21	D4	D4	IRQ11
LA20	D5	D5	IRQ12
LA19	D6	D6	IRQ15
LA18	D7	D7	IRQ14
LA17	D8	D8	DACK0-
MEMR-	D9	D9	DRQ0
MEMW-	D10	D10	DACK5-
SD8	D11	D11	DRQ5
SD9	D12	D12	DACK6-
SD10	D13	D13	DRQ6
SD11	D14	D14	DACK7-
SD12	D15	D15	DRQ7
SD13	D16	D16	+5
SD14	D17	D17	MASTER-
SD15	D18	D18	GND
keyed	D19	D19	GND

PC/104-Plus PCI Bus

The PC/104-Plus bus is essentially identical to the PCI Bus except for the physical design. A single pin and socket connector is specified for the bus signals. A 120-pin header, J3, arranged as four 30-pin rows incorporates a full 32-bit, 33MHz PCI Bus. The additional pins on the PC/104-Plus connectors are used as ground or key pins. The female sockets on the top of the board enable stacking another PC/104-Plus board on top of the Hercules II EBX board. The Hercules II EBX board should be the bottom board of a PC/104-Plus stackup.

In the connector J3 pinout table, below, the top corresponds to the left edge of the connector when the board is viewed from the primary side (the side with the CPU chip and the female end of the PC/104-Plus connector), and the board is oriented so that the PC/104 connectors are along the bottom edge of the board and the PC/104-Plus connector is in the center of the Hercules II EBX board.

Figure 4: J3 Connector

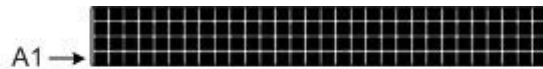

	A	B	C	D
1	GND/5.0V KEY	Reserved	+5V	AD00
2	VI/O	AD02	AD01	+5V
3	AD05	GND	AD04	AD03
4	C/BE0*	AD07	GND	AD06
5	GND	AD09	AD08	GND
6	AD11	VI/O	AD10	M66EN
7	AD14	AD13	GND	AD12
8	+3.3V	C/BE1*	AD15	+3.3V
9	SERR*	GND	SB0*	PAR
10	GND	PERR*	+3.3V	SDONE
11	STOP*	+3.3V	LOCK*	GND
12	+3.3V	TRDY*	GND	DESEL*
13	FRAME*	GND	IRDY*	+3.3V
14	GND	AD16	+3.3V	C/BE2*
15	AD18	+3.3V	AD17	GND
16	AD21	AD20	GND	AD19
17	+3.3V	AD23	AD22	+3.3V
18	IDSEL0	GND	IDSEL1	IDSEL2
19	AD24	C/BE3*	VI/O	IDSEL3
20	GND	AD26	AD25	GND
21	AD29	+5V	AD28	AD27
22	+5V	AD30	GND	AD31
23	REQ0*	GND	REQ1*	VI/O
24	GND	REQ2*	+5V	GNT0*
25	GNT1*	VI/O	GNT2*	GND
26	+5V	CLK0	GND	CLK1
27	CLK2	+5V	CLK3	GND
28	GND	INTD*	+5V	RST*
29	+12V	INTA*	INTB*	INTC*
30	-12V	Reserved	Reserved	GND/3.3V KEY

The PCI board interface is designed to allow different voltage levels for the signaling interface. The keying mechanism defined by the specification is intended to prevent a 3.3V-only device that is not 5V tolerant from receiving signals that are at a 5V signal rail. In a standard PCI interface, this is handled by blocking a portion of the edge connector such that the female connector is keyed as either “3.3V” or “5V”. This is intended to provide a way of preventing a 3.3V-only card in a 5V system. Many vendors choose to implement a “universal” edge connector that fits into either configuration; this is typically done in one of two ways:

- Use 3.3V signaling that is 5V-tolerant.
- Use the VIO pins on the PCI edge connector to power the I/O drive circuitry (or the maximum voltage overshoot protection circuitry) on the card.

From a system perspective, the primary question is, which standard can you support? Many card vendors choose to implement a specific standard, such as “5V only,” and connect the VIO signals to the internal power rail, such as “5V” signals on the PCI edge connector. While this is a violation of the more recent PCI specification, it is also relatively common, especially for card developers who developed PCI cards before the standard was updated for 3.3V support.

On the Hercules II EBX, all of the PCI circuitry is driven with 3.3V circuitry and is 5V tolerant. Given this, the Hercules II EBX main board can support either 3.3V or 5V-only cards. For this reason, the connector is not keyed (to prevent certain types of cards from being inserted). Rather, the main EBX board allows you to select which I/O voltage to use for a given PC/104-*Plus* card, or set of cards.

Many PC/104-*Plus* cards are universal, in which case the voltage setting does not matter, provided that it is set to either 3.3V or 5V. For cards that have a definite requirement, set the VIO jumper, J19, to the appropriate position.

According to the specification, a 5V-only card can be recognized by the keying position at location A1, where a male pin A1 cut and a female location A1 is blocked).

Similarly, cards that are to have 3.3V power should have pin D30 cut and female location D30 plugged.

Cards without either keying mechanism are “universal” and operate with either, 3.3V or 5V, I/O voltage.

Note: Do not mix cards that have different I/O keying requirements; i.e., do not stack a card that has pin A1 cut with a card that has pin D30 cut.

PS2 Mouse and Keyboard connector

Connector J6 is used to connect a mouse or keyboard. This connector mates with Diamond Systems Corporation cable no. 698022, which terminates the cable to two PS/2 Female connectors.

Figure 5: J6 Connector



1	+5vin (keyboard PS/2 pin 4)
2	Keyboard data (keyboard PS/2 pin 1)
3	Keyboard clock (keyboard PS/2 pin 5)
4	Ground (keyboard PS/2 pin 3)
5	+5v in (mouse PS/2 pin 4)
6	Mouse data (mouse PS/2 pin 1)
7	Mouse clock (mouse PS/2 pin 5)
8	Ground (mouse PS/2 pin 3)

Note: Pins 2 and 6 on the Mini-Din-6 PS/2 connectors are unused.

Utility Connector

Connector J7 provides access to the standard button/LED connections.

Figure 6: J7 Connector

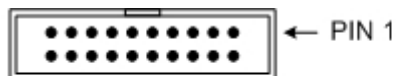

Ground	1	2	Reset key
Ground	3	4	ATX power button
Network activity LED	5	6	+3.3v standby
Network 100 Mbit link	7	8	+3.3v standby
+5v in	9	10	IDE LED
Power LED	11	12	External battery
Watchdog timer - input	13	14	Ground
Speaker	15	16	Watchdog timer - output
+5v in	17	18	IRTX (IR transmit)
IRRX (IR receive)	19	20	Ground

<i>Signal</i>	<i>Definition</i>
Reset key	Connection between Reset key and ground generate a reset condition. The board remains in a reset state (with non-standby power rails disabled) until Reset key is removed from ground.
ATX power button	<p>The ATX power button should be tied to ground whenever the “Power Button” is used. The “Power Button” has different functionality, depending on the current system mode and software operation. In general, the following guidelines apply.</p> <ul style="list-style-type: none"> • If the board is powered down, toggling (i.e., tie to ground briefly, then release) this button turns the system on, causing all non-standby voltages to become active. <p style="text-align: center;">NOTE: depending on the default configuration, the system usually powers-up immediately as power is applied.</p> <ul style="list-style-type: none"> • If the system is currently powered up and active, toggling (i.e., tie to ground briefly, then release) this button causes a system power-down event to be initiated. Typically, this powers-down the monitor, hard drive, and any other non-essential functions. The system must be operating and the software executing normally for this function. Under Windows and some other OSs, this power-down event may cause the system to shut down. Typically, this is software-configurable via an option setting for the given OS. • If the system is currently powered-up and active, holding this button for four seconds causes a forced system shutdown. This is a hardware power-down, which can be detrimental to many OSs due to the fact that they are not given adequate time to initiate shut-down sequencing. This operation should only be used in critical circumstances, such as when the system itself is locked due to system instability or a software crash. After powering the system down in this manner, the system remains powered down until the power button is toggled (tied to ground again and released). <p>When ATX is enabled, a momentary contact between this pin and Ground causes the CPU to turn on and a contact of four seconds or longer generates a power shutdown. ATX power control is enabled using a jumper on jumper block J4.</p>
+5v in	The +5v pin is a switched power pin that is turned on and off with either the ATX power switch or the +5v input.
+3.3v standby	The +3.3V standby pin provides a special “standby voltage” regardless of system power-down mode. This voltage is present whenever the system has power connected, regardless of the current system power-down state. This voltage is not intended as a major power-source for external devices. Instead, it is intended to allow external display of current system power status. This power supply should not be used unless absolutely necessary, in which case it should only be used as a source for LED display or similar power draw.
Network activity LED	The Network activity LED pin provides a signal that is the same as the LED marked “ACT” on the main board. It lights during receive or transmit activity on the Ethernet connection. An LED should be tied between power and this pin.
Network 100 Mbit link	The Network 100Mbit link pin provides a signal that is the same as the LED marked “100” on the main board. It lights whenever a 100MBit Ethernet link is established. An LED should be tied between power and this pin.
IDE LED	The IDE LED is referenced to +5V out and requires a series resistor. Connect the LED directly between this pin and resistor (to +5V).
Power LED	The Power LED referenced to +5V out does not require a series resistor. Connect the LED directly between this pin and +5V Out. Note that this displays the system main power. If the system is in a power-down mode, this LED may be inactive while the system is still receiving power to its standby voltage sources.
Speaker	The signal on the Speaker pin is referenced to +5V out. Connect a speaker between this pin and +5V out.

<i>Signal</i>	<i>Definition</i>
IRTX	The IR Receive/Transmit pins are used for IrDA functions. They should be connected to an external IrDA transceiver when needed. IR communications require that COM PORT 2 be set for "IR" mode for the IR serial port functionality to be active.
External battery	The External battery pin is an additional power connection for an external +3V power source, in addition to connector J20. Note that these two sources are not directly connected and may both be driven by separate external battery power sources. Typical power draw from this battery source averages under 4uA of current.
Watchdog timer	The Watchdog input/output signals are signals are used in conjunction with the on-board FPGA and Data Acquisition circuitry to provide full watchdog timer functionality.

Data Acquisition (Digital I/O) Connector

Hercules II EBX includes a 50-pin header, J8, for all digital data acquisition I/O. This header is located on the right side of the board. Pin 1 is the lower right pin, as marked on the board. Diamond Systems Corporation cable no. C-50-18 provides a standard 50-pin connector at each end and mates with this header.

Figure 7: J8 Connector

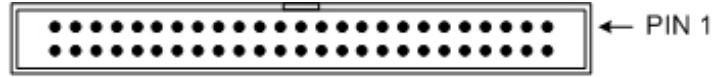

DIO A0	1	2	DIO A1
DIO A2	3	4	DIO A3
DIO A4	5	6	DIO A5
DIO A6	7	8	DIO A7
DIO B0	9	10	DIO B1
DIO B2	11	12	DIO B3
DIO B5	13	14	DIO B5
DIO B6	15	16	DIO B7
DIO C0	17	18	DIO C1
DIO C2	19	20	DIO C3
DIO C4	21	22	DIO C5
DIO C6	23	24	DIO C7
DIO D0	25	26	DIO D1
DIO D2	27	28	DIO D3
DIO D4	29	30	DIO D5
DIO D6	31	32	DIO D7
DIO E0/PWM0	33	34	DIO E1/PWM1
DIO E2/PWM2	35	36	DIO E3/PWM3
DIO E4/GATE1	37	38	DIOE5/TOUT1
DIO E6/DIOLATCH	39	40	DIO E7/GATE0
EXTTRIG	41	42	TOUT0
ACK	43	44	WDI
WDO	45	46	FXA
FXB	47	48	FXB
+5v	49	50	Digital ground

<i>Signal</i>	<i>Definition</i>
DIO A7-A0	Digital I/O port A; programmable direction
DIO B7-B0	Digital I/O port B; programmable direction
DIO C7-C0	Digital I/O port C; programmable direction
DIO D7-D0	Digital I/O port D; programmable direction
DIO E7-E0	Digital I/O port E; programmable direction Note : E3-E0 may be configured for PWM signals.
PWM3-PWM0	Pulse-Width Modulation Outputs (4 independent channels) Note : E7-E4 may be configured for counter/timer signals.
GATE 1-0	Gate inputs for Counter/Timer 1 and 0
TOUT1	Counter/Timer 1 output
DIOLATCH	Handshaking line used (with ACK signal below) for automated digital data transfers
Ext Trig	External A/D trigger input, External Counter/Timer 1 input
Tout 0	Counter/Timer 1 output
+5V Out	Connected to switched +5V supply (output only! Do not connect to external supply)
Digital Ground	Digital ground (0V - reference); used for digital circuitry only
WDO	Watchdog Timer Output NOTE: The watchdog timer circuit may be programmed directly or with Diamond Systems' Universal Driver software.
WDI	Watchdog Timer Input NOTE: The watchdog timer circuit may be programmed directly or with Diamond Systems' Universal Driver software.
ACK	Handshaking line used (with DIOLATCH signal) for automated digital data transfers
FXA, FXB	These lines should be left unconnected

Data Acquisition (Analog I/O) Connector

Connector J9 is used for analog I/O data acquisition.

Figure 8: J9 Connector

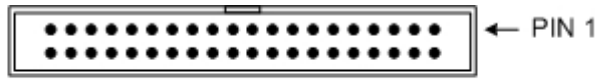

<i>Single-ended</i>			<i>Differential</i>				
Vout 0	1	2	Vout 1	Vout 0	1	2	Vout 1
Vout 2	3	4	Vout 3	Vout 2	3	4	Vout 3
Output ground	5	6	Output ground	Output ground	5	6	Output ground
Vin 0	7	8	Vin 16	Vin 0 +	7	8	Vin 16 -
Vin 1	9	10	Vin 17	Vin 1 +	9	10	Vin 17 -
Vin 2	11	12	Vin 18	Vin 2 +	11	12	Vin 18 -
Vin 3	13	14	Vin 19	Vin 3 +	13	14	Vin 19 -
Vin 4	15	16	Vin 20	Vin 4 +	15	16	Vin 20 -
Vin 5	17	18	Vin 21	Vin 5 +	17	18	Vin 21 -
Vin 6	19	20	Vin 22	Vin 6 +	19	20	Vin 22 -
Vin 7	21	22	Vin 23	Vin 7 +	21	22	Vin 23 -
Vin 8	23	24	Vin 24	Vin 8 +	23	24	Vin 24 -
Vin 9	25	26	Vin 25	Vin 9 +	25	26	Vin 25 -
Vin 10	27	28	Vin 26	Vin 10 +	27	28	Vin 26 -
Vin 11	29	30	Vin 27	Vin 11 +	29	30	Vin 27 -
Vin 12	31	32	Vin 28	Vin 12 +	31	32	Vin 28 -
Vin 13	33	34	Vin 29	Vin 13 +	33	34	Vin 29 -
Vin 14	35	36	Vin 30	Vin 14 +	35	36	Vin 30 -
Vin 15	37	38	Vin 31	Vin 15 +	37	38	Vin 31 -
Input ground	39	40	Input ground	Input ground	39	40	Input ground

<i>Signal</i>	<i>Definition</i>
Vout3-0	Analog output channels 3 – 0
Output Ground	Analog ground; 0V reference for <i>VOut3-0</i>
Vin 31 ~ Vin 0	Analog input channels 31 – 0 in single-ended mode
Vin 15 + ~ Vin 0 +	High side of input channels 15 – 0 in differential mode
Vin 15 - ~ Vin 0 -	Low side of input channels 15 – 0 in differential mode
Input Ground	Analog ground; 0V reference for <i>VIn31-0</i>

NOTE: These reference grounds are NOT decoupled from the power grounds – they are indirectly connected to the power supply input (and other on-board ground/0V references). Do not assume that these grounds are floating; do not apply a high-voltage input (relative to the power input ground) to these ground signals or to any other board I/O pin.

Ethernet Connectors

Ethernet connectivity is provided by connectors J10 and J11. Connector J10 is a board mounted RJ-45 connector and connector J11 is a 1x6 pin header. Connector J11 mates with Diamond Systems Corporation cable no. 698002, which provides a panel-mount RJ-45 jack for connection to standard CAT5 network cables.

For development, J10 may be more useful but it is anticipated that J11 will be more useful for embedded applications (for panel-mount network connection).

Figure 9: J10 and J11 Connectors



1	Common
2	RX-
3	Common
4	RX+
5	TX-
6	TX+

Note: Only one of the J11 or J10 connectors should be used at a time. Both connectors are NOT independent and neither will function if both are simultaneously connected.

Audio I/O Connector

Connector J12 provides audio connectivity.

Figure 10: J12 Connector



1	Left headphone/Line out
2	Right headphone/Line out
3	Audio ground
4	Left line input
5	Right line input
6	left AUX input
7	Right AUX input
8	Audio ground
9	power reference for microphone
10	Microphone input

<i>Signal</i>	<i>Definition</i>
Headphone/Line Out	Line Level output, capable of driving headphones, which is referred to as “Headphone Out” in most sound documentation.
Line Input	Line-Level input, which is referred to as “Line In” in most sound documentation.
Auxiliary Input	Line-Level input, which is referred to as “AUX In” in most sound documentation.
Microphone Input	Microphone-level mono input; phantom power provided via pin 9.

The Hercules II EBX sound chip is AC97-compatible. The “Line Out” is powered and used for the amplified Speaker Connector output, J13, described below. The line-level output listed above is listed as either “Headphone Out” or “Line Out 2” in most of the software and documentation for this sound interface.

Speaker Connector

Connector J13 is used to connect speakers.

Figure 11: J13 Connector

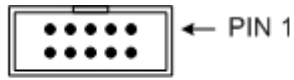

1	Speaker left high (+)
2	Volume - low
3	Speaker left low (-)
4	Volume - mid
5	Line level mono output
6	Audio ground
7	Speaker right low (-)
8	Volume - high
9	Speaker right high (+)
10	No-connect

<i>Signal</i>	<i>Definition</i>
Speaker LEFT +/-	Speaker Connection Pair for LEFT speaker (4-Ohm Speaker)
Speaker RIGHT +/-	Speaker Connection Pair for RIGHT speaker (4-Ohm Speaker)
Mono Output	Line-Level mono output (for reference)
Volume – LOW, MID, HIGH	These are volume controls for the attached speakers

The volume control is capable of 32 discrete levels, ranging from a 20dB maximum gain to -85dB (Muted). The main volume control is the “MID” line, which may be tied to the center tap of a potentiometer with “HIGH” on one side and “LOW” on the other to give a full range of power control.

- Shorting “MID” to “LOW” mutes the speaker audio.
- Shorting “MID” to “HIGH” provides maximum gain.
- Default (no connection) provides 10dB of gain.

The maximum output power is specified to provide up to two Watts into a 4-Ohm speaker load. Note that this output power is drawn from the on-board 5V supply.

The speakers are driven using a Bridged-Tied Load (BTL) amplifier configuration. This is a differential speaker connection. As such, each speaker should be wired directly to the appropriate pair of connections for that speaker.

- Do not connect the speaker low sides (-) to ground
- Do not short the speaker low connections together.

CD Input Connector

Connector J14 provides a connector for a PC-standard CD input cable.

Figure 12: J14 Connector



1	Left CD input
2	Left ground
3	Right ground
4	Right CD input

J14 provides the CD Audio Input to the AC97 Sound circuitry. The connector is an industry-standard CD-IN connector, which is common in most desktop Personal Computers. Note that the left and right grounds are decoupled but are also tied together on-board. This input is intended for CD-input only (i.e., no amplified or microphone inputs).

External Auxiliary Power Connector (Output)

Connector J15 provides switched power for use with external drives. If ATX is enabled, the power is switched ON and OFF with the ATX input switch. If ATX is not enabled, the power is switched ON and OFF in conjunction with the external power.

Figure 13: J15 Connector

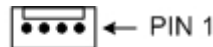

1	+5v (switched)
2	Ground
3	Ground
4	+12v (switched)

Signal	Definition
+5v	This is provided by the on-board power supply, derived from the input power. It is switched off when the board is powered down.
+12v	This is provided by the 12V input pin on the main power connector. It is switched off when the board is powered down.
Ground	These are 0V ground references for the power output voltage rails, above.

Diamond Systems Corporation cable no. 698006 mates with J15. This cable provides a standard full-size power connector for a hard drive or CD-ROM drive and a standard miniature power connector for a floppy drive.

Primary IDE Connector

Connector J16 is used for the primary IDE connection.

Figure 14: J16 Connector



Reset -	1	2	Ground
D7	3	4	D8
D6	5	6	D9
D5	7	8	D10
D4	9	10	D11
D3	11	12	D12
D2	13	14	D13
D1	15	16	D14
D0	17	18	D15
Ground	19	20	Key (not used)
DRQ	21	22	Ground
IDEIOW-	23	24	Ground
IDEIOR-	25	26	Ground
IORDY	27	28	Ground
DACK-	29	30	Ground
IRQ14	31	32	Pulled low for 16-bit operation
A1	33	34	Not used
A0	35	36	A2
CS0-	37	38	CA1-
LED-	39	40	Ground
+5v	41	42	+5v
Ground	43	44	Not used

Connector J16 mates with Diamond Systems Corporation cable no. 698004, and may be used to connect up to two IDE drives (hard disks, CD-ROMs, or flash disk modules). The 44-pin connector includes power and mates directly with notebook drives and flash disk modules. To use a standard format hard disk or CD-ROM drive with a 40-pin connector, an adapter PCB such as Diamond Systems Corporation ACC-IDEEXT is required.

Note: Connector J16 supports only up to ATA-33 (UDMA-2). It does not support ATA-66 (UDMA-3 to 5) transfer modes.

Secondary IDE Connector

Connector J17 is used for the secondary IDE connection.

Figure 15: J17 Connector

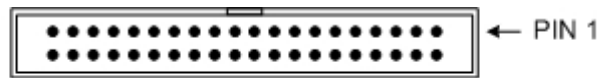

Reset -	1	2	Ground
D7	3	4	D8
D6	5	6	D9
D5	7	8	D10
D4	9	10	D11
D3	11	12	D12
D2	13	14	D13
D1	15	16	D14
D0	17	18	D15
Ground	19	20	Key (not used)
DRQ	21	22	Ground
IDEIOW-	23	24	Ground
IDEIOR-	25	26	Ground
IORDY	27	28	Ground
DACK-	29	30	Ground
IRQ14	31	32	Pulled low for 16-bit operation
A1	33	34	Not used
A0	35	36	A2
CS0-	37	38	CA1-
LED-	39	40	Ground

Connector J17 mates with Diamond Systems Corporation UDMA cable no. 698026, and may be used to connect up to two IDE drives (hard disks, CD-ROMs or other IDE/ATAPI devices). The 40-pin connector must mate with this 80-conductor UDMA cable for maximum performance. Connector J17 fully supports up to ATA-100 (UDMA Mode 5), provided that an appropriate UDMA (80-conductor) cable is used.

Note: The cable type is automatically be detected by the BIOS and the transfer speed is limited as necessary.

Serial Port I/O Connector

Connector J18 is a 40-pin header that provides access to the four on-board serial ports. The PORT1 and PORT2 serial ports are always configured for RS-232. The PORT3 and PORT4 serial ports are software configurable as either RS-232, RS-485 or RS-422. All four serial ports are independently enabled. The last two serial ports can be independently configured between the RS-232, RS-485 and RS-422 modes of operation.

Figure 16: J18 Connector

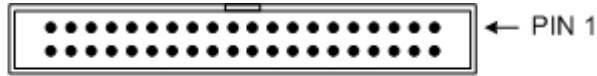

<i>Port No.</i>	<i>Pin Assignment</i>
PORT1	Pins 1 - 10
PORT2	Pins 11 - 20
PORT3	Pins 21 - 30
PORT4	Pins 31 - 40

Diamond Systems Corporation Cable Assembly Number C-DB9M-4 connects this header to four DE-9 Male connectors, for direct connection to RS-232-C signaling. The following tables list the signals for the appropriate mode of operation, as well as the DE-9 pin numbers to which these signals are wired.

RS-232 Pin Assignment

COM1:	DCD1	1	2	DSR1
	RXD1	3	4	RTS1
	TXD1	5	6	CTS1
	DTR1	7	8	RI1
	GND	9	10	N/C
COM2:	DCD2	11	12	DSR2
	RXD2	13	14	RTS2
	TXD2	15	16	CTS2
	DTR2	17	18	RI2
	GND	19	20	N/C
COM3:	DCD3	21	22	DSR3
	RXD3	23	24	RTS3
	TXD3	25	26	CTS3
	DTR3	27	28	RI3
	GND	29	30	N/C
COM4:	DCD4	31	32	DSR4
	RXD4	33	34	RTS4
	TXD4	35	36	CTS4
	DTR4	37	38	RI4
	GND	39	40	GND

<i>Signal</i>	<i>Definition</i>	<i>DE-9 Pin</i>	<i>Direction</i>
DCD _n	Data Carrier Detect	pin 1	Input
DSR _n	Data Set Ready	pin 6	Input
RXD _n	Receive Data	pin 2	Input
RTS _n	Request to Send	pin 7	Output
TXD _n	Transmit Data	pin 3	Output
CTS _n	Clear to Send	pin 8	Input
DTR _n	Data Terminal Ready	pin 4	Output
RI _n	Ring Indicator	pin 9	Input
NC	(not connected)	-	-
GND	Ground	-	-

RS-485 Pin Assignment

Only J18 connector pins 21 through 40, PORT3 and PORT4, are used for RS-485.

COM3:	NC	21	22	NC
	TXD/RXD+3	23	24	TXD/RXD-3
	GND	25	26	NC
	NC	27	28	NC
	GND	29	30	DIOC
<hr/>				
COM4:	NC	31	32	NC
	TXD/RXD+4	33	34	TXD/RXD-4
	GND	35	36	NC
	NC	37	38	NC
	GND	39	40	DOI

<i>Signal</i>	<i>Definition</i>	<i>DE-9 Pin</i>	<i>Direction</i>
TXD/RXD+ _n	Differential Transceiver Data (HIGH)	pin 2	bi-directional
TXD/RXD- _n	Differential Transceiver Data (LOW)	pin 7	bi-directional
GND	Ground	-	-
NC	(not connected)	-	-

RS-422 Pin Assignment

Only J18 connector pins 21 through 40, PORT3 and PORT4, are used for RS-422.

COM3:	NC	21	22	NC
	TXD+1	23	24	TXD-1
	GND	25	26	RXD-1
	RXD+1	27	28	NC
	GND	29	30	NC
COM4:	NC	31	32	NC
	TXD+2	33	34	TXD-2
	GND	35	36	RXD-2
	RXD+2	37	38	NC
	GND	39	40	NC

<i>Signal</i>	<i>Definition</i>	<i>DE-9 Pin</i>	<i>Direction</i>
TXD+n/TXD-n	Differential transmit data	-	Output
RXD+n/RXD-n	Differential receive data	-	Input
GND	Ground	-	-
NC	(not connected)	-	-

External Battery Connector

Connector J20 is used to connect an external battery. The battery voltage for this input should be 3-3.5V. The current draw averages under 4uA at 3V.

Figure 17: J20 Connector



1	Battery input
2	Ground

In addition to the external battery connected to J20, the on-board battery and an additional external battery input on Utility Connector J7 are other possible sources for maintaining the Real-Time Clock and the CMOS settings (BIOS settings for various system configurations). The battery that has the highest voltage will see the majority of the current draw, which is minimal. Note that there must be a battery voltage input for the default power-up mode.

USB 1.1 Connectors

Connectors J21 and J22 are used to connect USB 2/3 and USB 0/1, respectively, and support USB 1.1 with 10Mbps maximum data transfer rates.

Figure 18: J21 and J22 Connectors

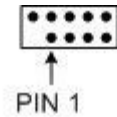

Key (pin cut)	1	2	Shield
USB1/3 power-	3	4	USB0/2 power-
USB1/3 data+	5	6	USB0/2 data+
USB1/3 data-	7	8	USB0/2 data-
USB1/3 power+	9	10	USB0/2 power+

<i>Signal</i>	<i>Definition</i>
Shield	-
USB0/2 power-	ground
USB0/2 data+	data +
USB0/2 data-	data -
USB0/2 power+	+5V
USB1/3 power-	ground
USB1/3 data+	data +
USB1/3 data-	data -
USB1/3power+	+5V

Connectors J21 and J22 mate with Diamond Systems Corporation cable no. 698012, which provides two standard USB type A jacks in a panel-mount housing.

Note: USB1, described below, shares the J22 USB circuitry. Do not connect USB devices to both USB1, on J23, and J22.

USB1 Connector

Connector J23 provides a single, quick and simple on-board USB connection for simple test and development without requiring an additional cable.

Figure 19: J23 Connector

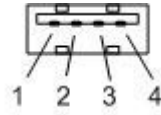

1	power+
2	data-
3	data+
4	power-

<i>Signal</i>	<i>Definition</i>
power-	ground
data+	data +
data-	data -
power+	+5V

Note: USB1 shares the J22 USB circuitry. Do not connect USB devices to both USB1 and J22.

LCD Panel (LVDS Interface) Connector

Connector J24 provides access to the internal LVDS LCD display drivers. Note that the LCD also requires the backlight to be connected (J28 below) to function correctly.

Ground	1	2	Ground
Y clock-	3	4	Z clock-
Y clock+	5	6	Z clock+
Ground	7	8	Ground
Y data 0-	9	10	Z data 0-
Y data 0+	11	12	Z data 0+
Ground	13	14	Ground
Y data 2-	15	16	Z data 1-
Y data 2+	17	18	Z data 1+
Ground	19	20	Ground
Y data 1-	21	22	Z data 2-
Y data 1+	23	24	Z data 2+
Ground	25	26	Ground
VDD (LDC display)	27	28	VDD (LCD display)
VDD (LDC display)	29	30	VDD (LCD display)

<i>Signal</i>	<i>Definition</i>
Y Data 2-0 +/-	Primary Data Channel, bits 2-0 (LVDS Differential signaling)
Y Clock +/-	Primary Data Channel, Clock (LVDS Differential signaling)
Z Data 2-0 +/-	Secondary Data Channel, bits 2-0 (LVDS Differential signaling)
Z Clock +/-	Secondary Data Channel, Clock (LVDS Differential signaling)
VDD	+3.3V Switched Power Supply for LCD display (only powered up when LCD display is active)
Ground	Power Ground, 0V

VGA Connector

Connector J25 provides a connection for VGA monitors.

Figure 20: J25 Connector

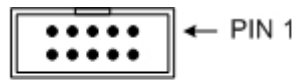

Red	1	2	R-ground
Green	3	4	G-ground
Blue	5	6	B-ground
HSYNCH	7	8	DDC data
VSYNCH	9	10	DDC clock

<i>Signal</i>	<i>Definition</i>
RED	RED signal (positive, 0.7Vpp into 75 Ohm load)
R-Ground	Ground return for RED signal
GREEN	GREEN signal (positive, 0.7Vpp into 75 Ohm load)
G-Ground	Ground return for GREEN signal
BLUE	BLUE signal (positive, 0.7Vpp into 75 Ohm load)
B-Ground	Ground return for BLUE signal
DDC-CLOCK/DATA	Digital serial I/O signals used for monitor detection (DDC1 specification)

Diamond Systems Corporation Cable Assembly #698024 provides a female DB15 connection to interface with a standard RGB monitor.

Note: While the DDC serial detection pins are present, a 5V power supply is not provided (the old “Monitor ID” pins are also not used).

Video/TV Out Connector

Connector J26 provides a video output for connection to a standard (NTSC) TV. Either S-Video (6-pin mini-DIN) or Composite (RCA Jack) can be used, but not both.

Figure 21: J26 Connector

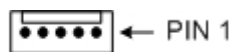

1	S video Y
2	S video C
3	Composite
4	Ground
5	NC

<i>Signal</i>	<i>Definition</i>
S-Video "Y"	S-Video "Brightness" (Luminance)
S-Video "C"	S-Video "Color" (Chrominance)
Composite	Composite Video
Ground	Ground (for either S-Video or Composite)
NC	Do not connect this signal; For testing use only

Notes:

- **This feature requires software support to function, and is not directly supported in the BIOS.**
- **LCD, S-Video, and Composite are mutually-exclusive. It is not possible to have more than one of these options active at the same time.**

CPU Fan Connector

Connector J27 is used to connect to the CPU fan.

Figure 22: J27 Connector

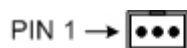

1	Fan RPM
2	Ground
3	+5v

<i>Signal</i>	<i>Definition</i>
Fan RPM	TTL signal input that pulses with each revolution of the fan.
+5V, Ground	Power Supply for optional CPU Fan, if necessary.

LCD Backlight Connector

Connector J28 provides the backlight power and control for the optional LCD panel. See the description for connector J24, above, for details on the LCD data interface.

Figure 23: J28 Connector

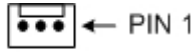

1	+12v
2	Control
3	Ground

<i>Signal</i>	<i>Definition</i>
Control	Output signal (from Hercules II EBX) to allow power-down of backlight
+12V	Power supply for LCD Backlight assembly
Ground	Ground for LCD Backlight assembly

The control signal is used to allow the system to power-down the backlight when the system enables monitor-power-down during power management control.

The +12V supply is removed when the system is powered down.

Low-Voltage Power Input Connector

The standard Hercules II EBX input power is supplied through the J29 connector from an external mid-range supply. (An option for higher-voltage power supply input may be available).

Figure 24: J29 Connector



1	+Vin
2	+Vin
3	Ground
4	Ground
5	+12v
6	Ground
7	+Vin
8	-12v
9	-5v
10	Power supply ON

<i>Signal</i>	<i>Definition</i>
+Vin	Main input power; +5V to +28V (optional) input range.
Ground	0-V (ground) power return path.
+12V	Power supply for in-board 12V devices, including hard drives, auxiliary power, PC/104 power, and LCD backlight. Range should be 11.9V to 13.5V measured at this connector.
-12V	Power supply for PC/104- <i>Plus</i> -12V devices (no on-board devices).
-5V	Power supply for PC/104- <i>Plus</i> -5V devices (no on-board devices).
Power Supply ON	Feedback pin for external ATX supply, when needed; pulled low when on-board power is inactive.

Hercules II EBX in the standard, mid-range power input configuration supports a voltage range from +4.75V to +28V, with some restrictions. For input voltages from +4.75V to 6V, measured at J29, the function of some 5V devices may be affected due to high-current draw and voltage dips encountered due to current variations. In this case, the following behavior may be observed.

- Hard drives attached to the system may not power up correctly and/or may reset.
- Hard drives, CD-ROMs, and other high-power devices may also draw too much power at these low voltages, causing the system to reset. External power supplies for high-power devices are strongly recommended when the input supply is likely to be this low.
- PS/2 and USB devices may function erratically or not at all at low input voltages. An external powered USB hub may alleviate this problem somewhat; this includes USB keyboards, mice, and especially USB boot devices, such as floppy drives and USB flash drives.
- RS-232 range and functionality may be degraded.
- Audio speaker output power may be limited.
- Data acquisition accuracy may be slightly affected.

At input voltage ranges above 6V (6V to 28V), these concerns are not present. The main input voltage, “Vin,” is used to derive all on-board voltages and power supplies via on-board switching regulators.

The “+12V” power supply input is intended for all on-board and board-controlled 12V power supplies, including the PC/104-*Plus* 12V supplies, the external hard drive power supply (through connector J15, described above), and the LCD backlight. If these devices are not used, the “+12V” input may be left unconnected.

Since the PC/104 bus includes pins for -5V and -12V, these voltages may be supplied through connector J29 if needed and left unconnected if not needed.

The +5V and +12V voltages are controlled by the ATX power manager switches, while -5V and -12V are routed directly to the corresponding pins on the PC/104 bus and are not controlled by the ATX function.

Make certain that your power supply has enough current capacity to drive your system. The Hercules II EBX requires 12 to 20 Watts or more, depending on which external devices are connected to the board. This could require over 4A on the “+Vin” line at minimum voltage inputs. In particular, many disk drives need extra current during startup. If your system fails to boot properly or if disk accesses do not work correctly, the first thing to check is the power supply voltage level at connector J29. Many boot-up problems are caused simply by insufficient voltage due to excess current draw on the “+Vin” supply during initialization.

Multiple +5V and ground pins are provided for extra current carrying capacity, if needed. Each pin is rated at 3A max (15W). For the Hercules II EBX CPU with a moderate I/O device complement (basic hard drive, key board, mouse, USB devices, and a network PC/104-Plus card, for example), 1.4A at +13V is considered sufficient.

ATX control enables the +5V and +12V power to be switched ON and OFF with an external momentary switch. A short press on the switch turns ON power, and holding the switch on for four seconds or longer turns OFF power (See the Utility Header description for connector J7, above).

Diamond Systems Corporation cable no. 698015 mates with connector J29. The cable provides ten color-coded wires with stripped and tinned leads for connection to user-supplied power sources.

For cases where the input power supply is 12V, the “+Vin” and “+12V” input wires may be connected. In this case, ensure that the power supply into the “+12V” does not exceed the voltage requirements for that input pin.

High-Voltage Power Input Connector (Optional)

Connector J30 is used for high-voltage power input, which is optionally available for special, higher-voltage applications. This option is intended to allow for a higher power supply input than the standard power input provided using connector J29.

Figure 25: J30 Connector



1	Ground
2	+Vwin

<i>Signal</i>	<i>Definition</i>
+Vwin	Main input power (+13V to +40V input range).
Ground	0V (ground) power return path.

CompactFlash Slot (optional)

A CompactFlash Socket is located under the board at connector J34, immediately under connector J17. If this socket is used, it occupies the entire secondary IDE channel. To set the CompactFlash card as an IDE MASTER, so it is detected by the BIOS, place a jumper on connector J5, as described in the following section.

USB 2.0 Connectors

Connectors J36 and J37 are 2x5 pin headers for connecting USB 6/7 and USB 4/5, respectively, providing USB 2.0 support (480Mbps maximum transfer rates). These connectors mate with Diamond Systems Corporation cable no. 698012, which provides 2 standard USB type A jacks in a panel-mount housing.

Figure 26: J36 and J37 Connectors

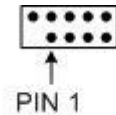

Key (pin cut)	1	2	Shield
USB5/7 power-	3	4	USB4/6 power-
USB5/7 data+	5	6	USB4/6 data+
USB5/7 data-	7	8	USB4/6 data-
USB5/7 power+	9	10	USB4/6 power+

<i>Signal</i>	<i>Definition</i>
Shield	-
USB4/6 power-	ground
USB4/6 data+	data +
USB4/6 data-	data -
USB4/6 power+	+5V
USB5/7 power-	ground
USB5/7 data+	data +
USB5/7B data-	data -
USB5/7 power+	+5V

Board Configuration

The Hercules II EBX board has the following jumper-selectable configuration options.

- Serial Port and A/D IRQ Settings
- ATX Power Control
- Erasing CMOS RAM
- RS-485 Termination Settings
- RS-422 Termination and Selection
- Serial Port Address Setting
- Optional CompactFlash IDE Control
- Write-Protect BIOS Flash
- DIO Pull-up/Pull-Down Selections
- PCI VI/O Voltage Setting

Jumper blocks J4, J5 and J19 are used for the following configuration functions.

<i>Jumper Block</i>	<i>Configuration Functions</i>
J4	Serial port and A/D IRQ settings ATX power control Erasing CMOS RAM RS-485 termination settings RS-422 termination and selection
J5	Serial port address setting CompactFlash IDE control Write-protect BIOS flash DIO pull-up/pull-down selections
J19	PCI VI/O voltage setting
J35	Crisis recovery

Jumper Block J4

Jumper block J4 is used for configuration of IRQ levels, ATX power control, RS485 termination, RS422 mode and CMOS RAM.

Figure 27: Jumper Block J4 Default Settings

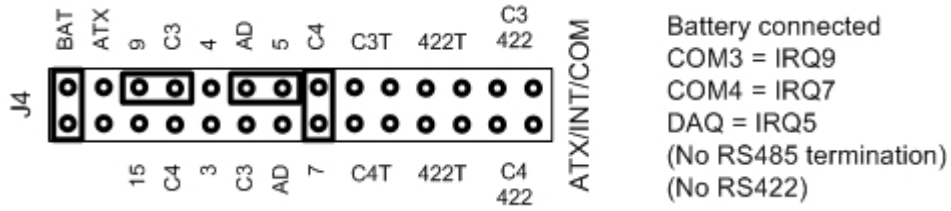

<i>J4</i>	
<i>Pin Label</i>	<i>Function</i>
BAT	Battery connected: in - battery connected (CMOS RAM settings preserved) out - battery not connected (CMOS RAM settings erased)
ATX	ATX power control in - ATX-like power control out - standard (powers up immediately)
3 4 5 7 9 15	IRQ 3; selectable for COM3, COM4 IRQ 4; selectable for COM3, ADC IRQ 5; selectable for ADC IRQ 7; selectable for ADC IRQ 9; selectable for COM3 IRQ 15; selectable for COM4 (use with pins C3, C4, AD)
C3 C4	COM3 select, for IRQ COM4 select, for IRQ (use with pins 3, 4, 5, 7, 9, 15)
AD	ADC select, for IRQ (use with pins 4, 5, 7)
C3T C4T	COM3 RS-485 termination COM4 RS-485 termination in - terminates 120-Ohm, onboard
422T	RS-422 Termination
C3 422 C4 422	COM3 RS-422 enable COM4 RS-422 enable in - override RS-232/RS-485 in BIOS out - RS-422 disabled

Serial Port and A/D IRQ Settings

COM3 may be directly set to IRQ3, IRQ4, or IRQ9. COM4 may be directly set to IRQ3, IRQ7 or IRQ15. The A/D circuit (on models that include Data Acquisition) may be set to IRQ4, IRQ5, or IRQ7. It is possible to share an interrupt with an on-board resource (to share IRQ3 with COM2, for example), provided that the OS or driver can handle the IRQ sharing.

Figure 27 shows how to select the IRQ for COM3 and COM4.

Figure 28: J4 COM3/COM4 IRQ Selection Examples

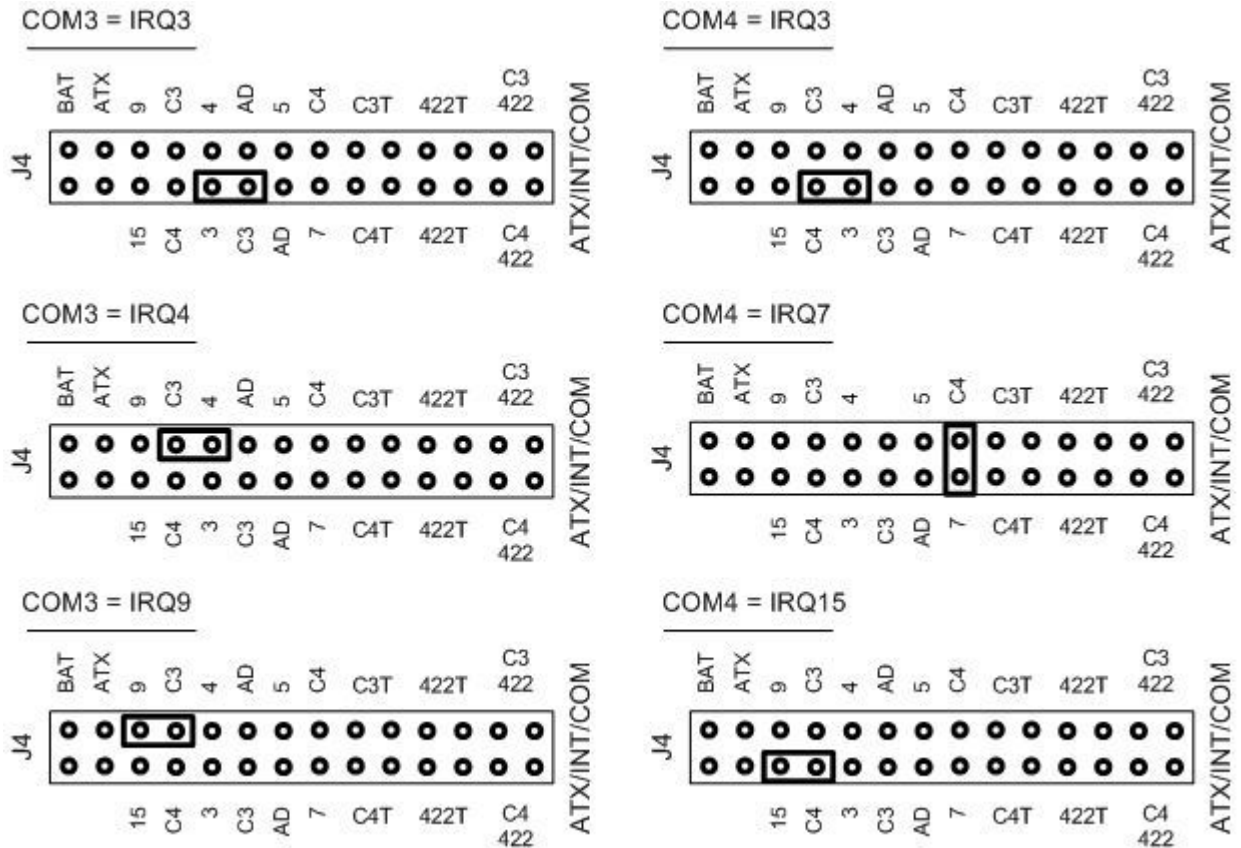
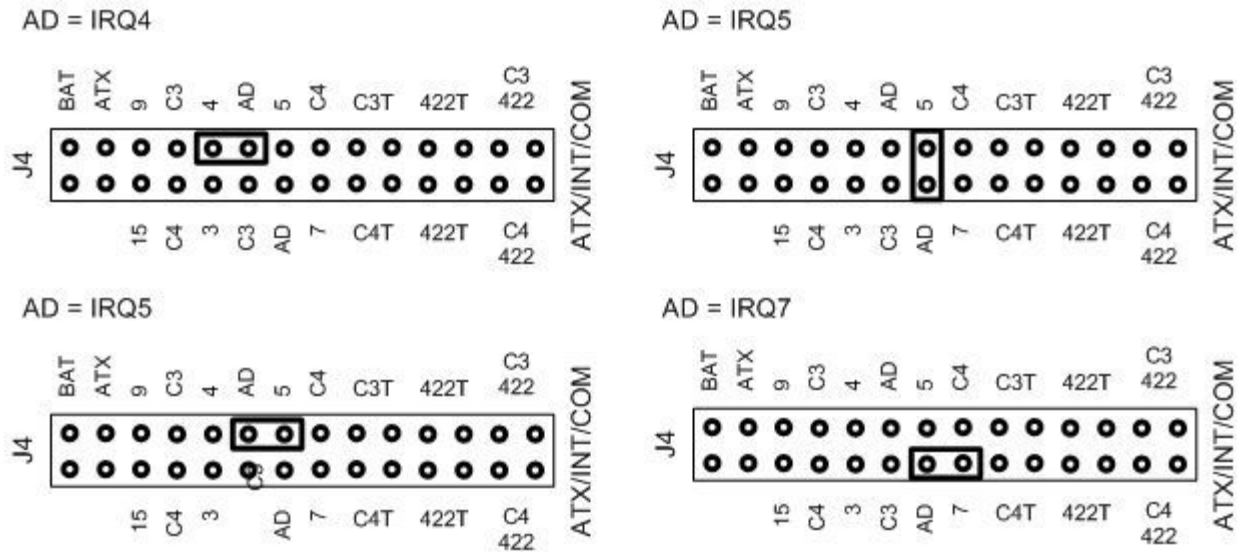

Figure 29 shows how to select the IRQ for the A/D circuit.

Figure 29: A/D IRQ Selection Examples



ATX Power Control

The ATX power control is set using the J4 ATX jumper, shown in Figure 30.

Figure 30: ATX Power Control Jumper

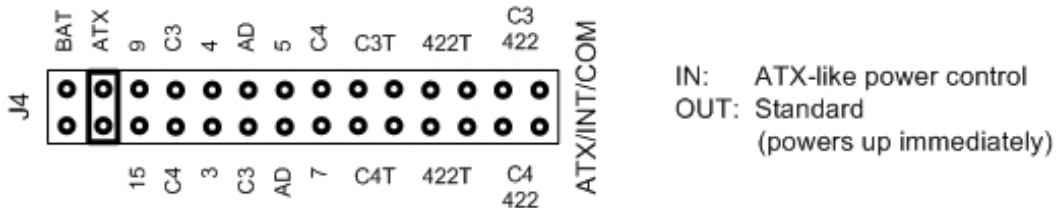

If the ATX jumper is in, ATX works normally, and an external, momentary switch may be used to turn power ON and OFF. A quick contact turns the power ON, and a long contact (greater than four seconds) turns the power OFF.

If the ATX jumper is out, the ATX function is bypassed and the system powers up as soon as power is connected.

If the ATX jumper is removed, the battery-backup for CMOS and real-time clock settings do not function when power is removed.

Erasing CMOS RAM

The CMOS RAM may be cleared by removing the J4 BAT jumper, shown in Figure 31.

Figure 31: CMOS RAM Erase Jumper

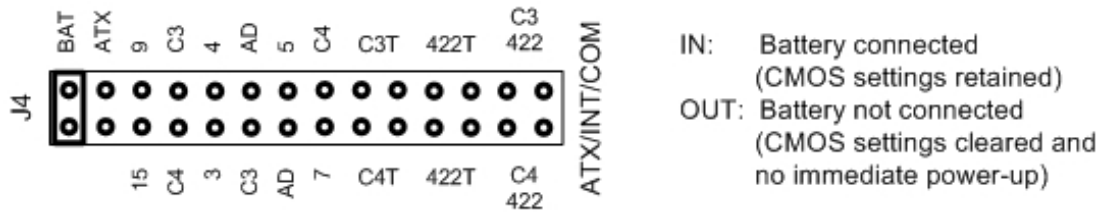

With the jumper in place, the CPU powers up with the default BIOS settings. Follow these steps to clear the CMOS RAM.

1. Power-down the CPU.
2. Remove the BAT jumper.
3. Wait a few seconds.
4. Insert the BAT jumper.
5. Power-up the CPU.

Note: Before erasing CMOS RAM, write down any custom BIOS settings.

RS-485 Termination Settings

Use jumper C3T for COM3 and C4T for COM4, for on-board 120-Ohm termination of the RS-485 signal, as shown in Figure 32.

Figure 32: COM3 and COM4 RS485 Termination Jumpers

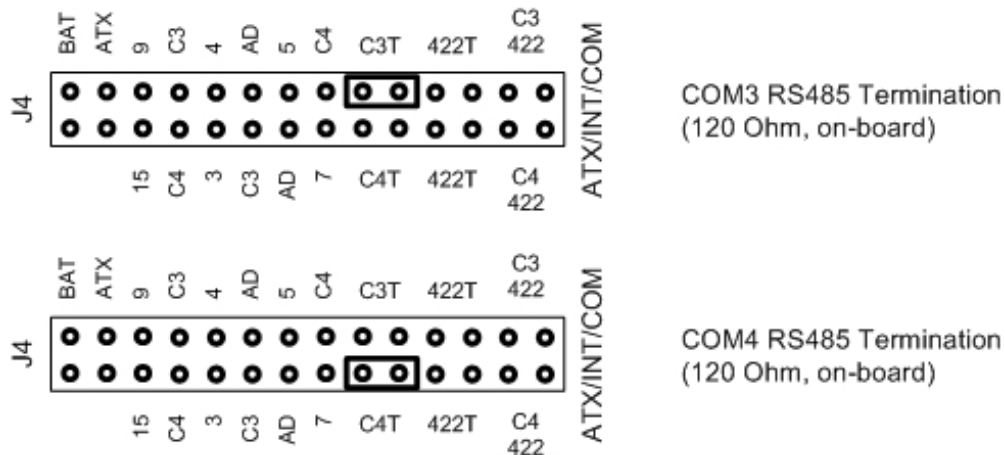

RS-422 Termination and Selection

When RS-422 is selected, jumper J4 pin 422T to terminate the RS-422 line.

Normally, RS-232/RS-485 is selected in the BIOS. However, to override the BIOS setting, jumper J4 pin C3 422 to select RS-422 for COM3 and jumper C4 422 to select RS-422 for COM4, as shown in Figure 33.

Figure 33: COM3 and COM4 RS422 Termination Jumpers

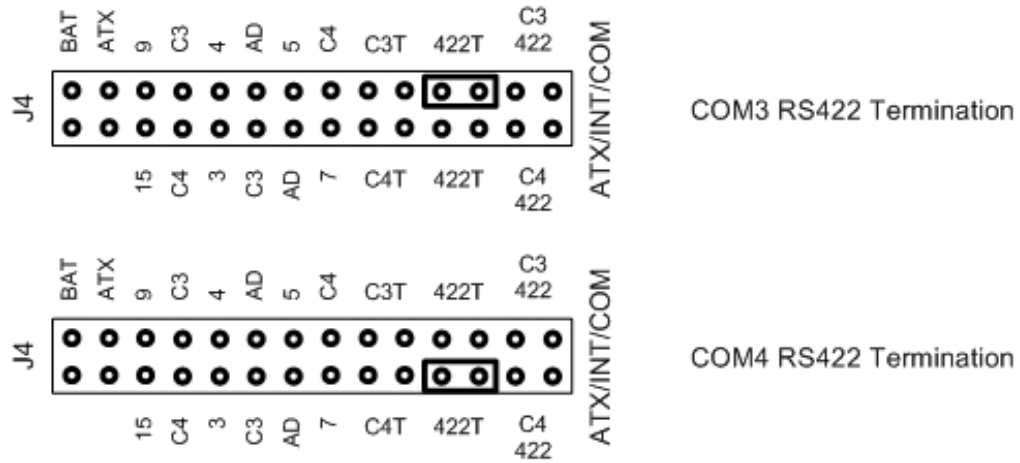

Jumper Block J5

Jumper block J5 is used to configure DIO pull-ups/pull-downs, DIO control signal pull-ups/pull-downs, CompactFlash mode, flash write protect (for boot sector), and COM3/4 address selection.

Figure 34: Jumper Block J5 Default Settings

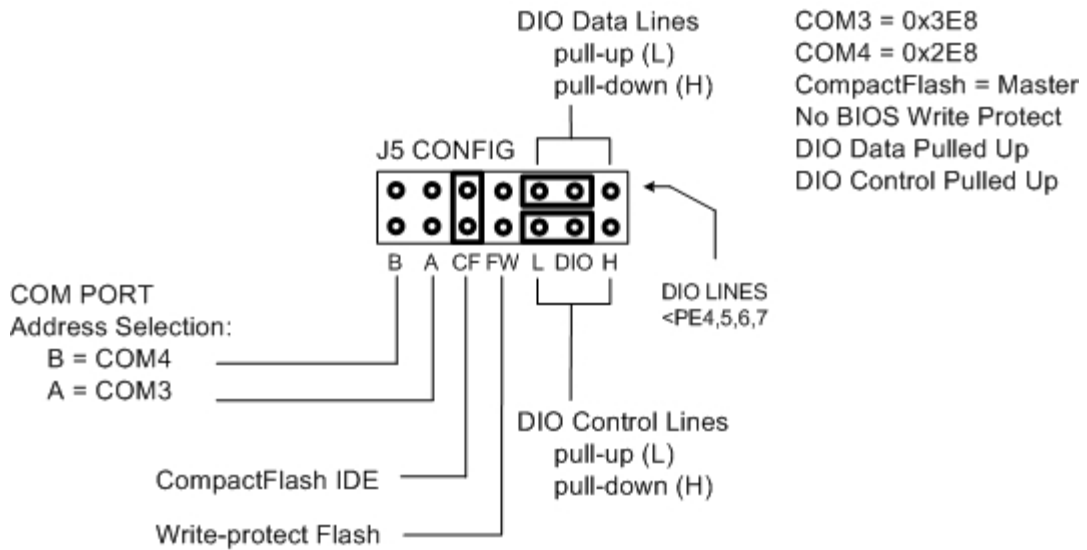

J5	
Pin Label	Function
B	COM4 port address selection: in - 0x03E8 out - 0x02F8
A	COM3 port address selection: in - 0x02F8 out - 0x03E8
CF	CompactFlash IDE: in - master out - slave (default)
FW	(reserved for future use)
L DIO H	DIO control lines, pull-up/pull-down: jumper DIO-L - pull down jumper DIO-H - pull up
unlabeled pins opposite pins L, DIO, H	DIO data lines, pull-up/pull-down: jumper DIO-L - pull down jumper DIO-H - pull up

Serial Port Address Setting

COM3 and COM4 I/O address may be set to either 0x03E8 or 0x02F8, as shown in Figure 28.

Figure 35: COM3/COM4 I/O Address Selection

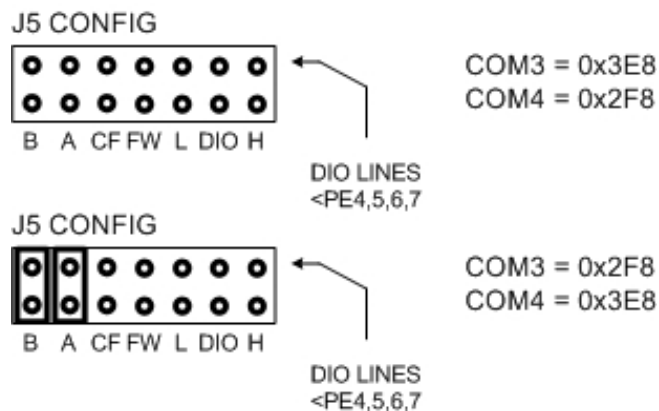

These settings are effective immediately. However, the BIOS must start with these jumpers in position to correctly detect and configure the ports.

Note: Change these settings only while the system is powered down.

CompactFlash IDE Control (Optional)

The optional CompactFlash slot on the back of the board is configured to the secondary IDE channel, and can be detected as either a *master* or a *slave* device. When configured as a *slave* device, a *master* device on the same IDE

channel is required for the CompactFlash to function. Figure 39 shows the jumper setting for selecting *master* or *slave* mode.

Figure 36: CompactFlash Master/Slave Selection Jumper

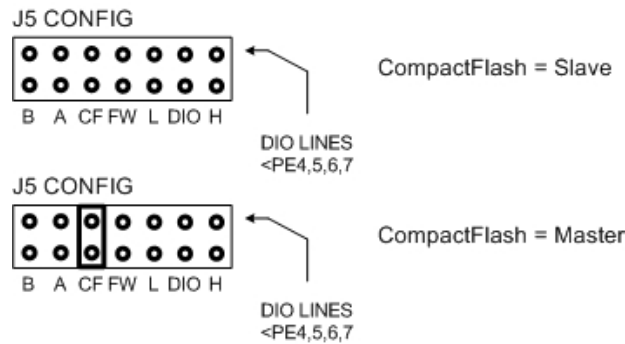

DIO Pull-up/Pull-Down Selections

The digital I/O lines in the data acquisition section are broken into two blocks: general purpose DIO lines (DIO channels A-D, and Channel E bits 3-0), and multiplexed control lines (DIO Channel E bits 7-4).

The top three J5 DIO pins allow for a pull-down (left jumper) or pull-up (right jumper) selection for the general-purpose pins. The bottom three J5 DIO pins allow a similar selection for the multiplexed control lines. This allows these alternate-function pins to be selected separately, since their function may require a different default state than that provided to the standard digital I/O lines. Figure 38 shows the data and control line jumper selections.

Figure 37: DIO Pull-up/Pull-down Selection Jumpers

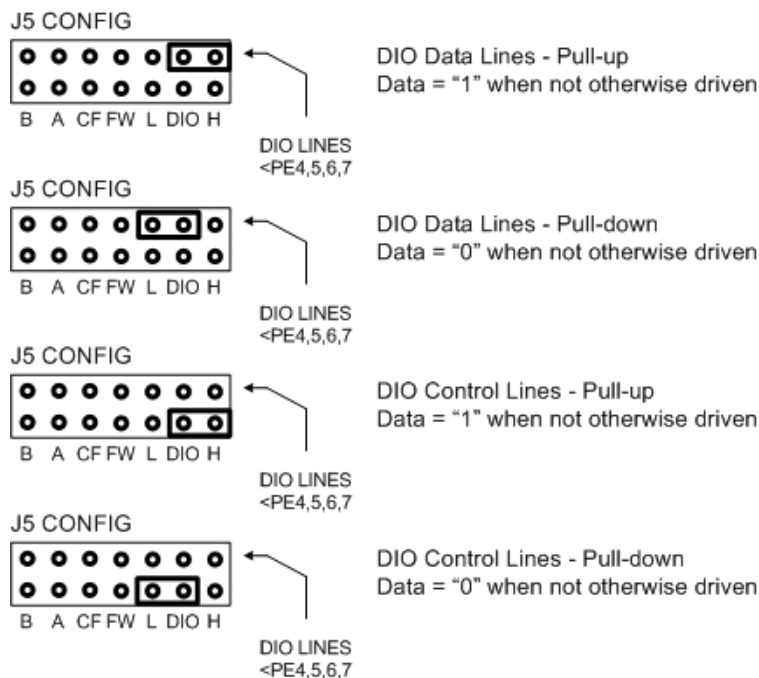

Jumper Block J19 - PCI VIO Voltage Selection

J19 provides simple access to the VIO setting for PC/104-*Plus* cards. This setting sets the voltage supplied on the “VIO” power pins of the PC/104-*Plus* connector (J3). Note that the “VIO” voltage is used on most cards to supply the I/O Voltage for all PCI signals.

Figure 38: Jumper Block J19



<i>J19</i>	
<i>Pin Label</i>	<i>Function</i>
3	Main +3.3v power supply on board connect pins 3-PCI VIO to select +3.3v
PCI VIO	PCI VIO for selecting either +3.3v or +5v onboard power supply.
5	Main +5v power supply on board connect pins 5-PCI VIO to select +5v

The Hercules II EBX can support either I/O voltage range (all on-board signals are driven from 3.3V power rails, but are 5V tolerant), so the determination of the I/O voltage is entirely dependent on the types of PC/104-*Plus* cards plugged into the system.

PC/104-*Plus* cards should be keyed to identify the correct voltage setting. No key means that the card is universal and can accept either power setting. There are essentially 4 possibilities:

- Card keyed for 5V
- Card keyed for 3.3V
- Card not keyed – universal (can operate with either voltage setting)
- Card incorrectly keyed or not keyed but with certain requirements

The first three possibilities can be easily determined by checking the keying of the card, as shown in the following table.

<i>Card Voltage Type</i>	<i>Pin Configuration</i>
5V card	Pin A1 missing/pin D30 present
3.3V card	Pin A1 present/pin D30 missing
Universal card	Pin A1 present/pin D30 present

The only solution for cards that are incorrectly keyed is to read the documentation and verify the I/O voltage (if it is called out in the card description). While not a widespread issue, this is something to be aware of when starting to work with a new PC/104-*Plus* card.

Note that this voltage selection is not used for standard PC/104 cards; only the PCI-signaling of PC/104-*Plus*.

Figure 34 shows how to select the desired voltage using jumper J19.

Figure 39: J19 Voltage Selection

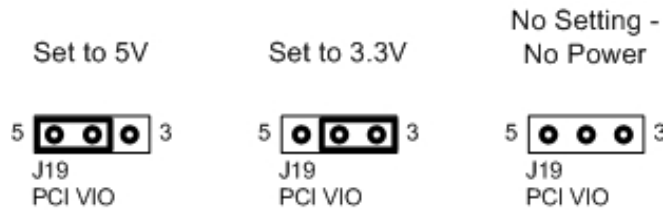

Jumper 35 - Crisis Recovery

The BIOS can be forced to update by shorting the two crisis recovery pads, located just below the J18 connector. If the crisis recovery pins are shorted as the board powers-up and enters self-test, the board immediately searches for a USB floppy device on any of the four USB ports. Once a drive is found, the board for a special crisis recovery disk, which is provided by Diamond Systems Corporation. If a valid recovery disk is found, the board immediately begins loading and updating the BIOS.

Refer the the BIOS section of this document for a description of the BIOS recovery steps.

System Features

System Resources

The table below lists the default system resources utilized by the circuits on Hercules II EBX.

<i>Device</i>	<i>Address</i>	<i>ISA IRQ</i>	<i>ISA DMA</i>
Serial Port COM1	I/O 0x3F8 – 0x3FF	4	–
Serial Port COM2	I/O 0x2F8 – 0x2FF	3	–
Serial Port COM3	I/O 0x3E8 – 0x3EF	9	–
Serial Port COM4	I/O 0x2E8 – 0x2EF	7	–
IDE Controller A	I/O 0x1F0 – 0x1F7	14	–
IDE Controller B	I/O 0x170 - 0x177	15	–
A/D Circuit (when applicable)	I/O 0x240 – 0x25F	5	–
Serial Port / FPGA Control	I/O 0xA50-0xA5F	–	–
Ethernet	OS-dependent	OS-dependent	–
USB	OS-dependent	OS-dependent	–
Sound	OS-dependent	OS-dependent	–
Video	OS-dependent	OS-dependent	–

Most of these resources are configurable and, in many cases, the Operating System alters these settings. The main devices that are subject to this dynamic configuration are on-board Ethernet, sound, video, USB, and any PC/104-*Plus* cards that are in the system. These settings may also vary depending on what other devices are present in the system. For example, adding a PC/104-*Plus* card may change the on-board Ethernet resources.

The serial port settings for COM3 and COM4 are jumper selectable, whereas the settings for COM1 and COM2 are entirely software-configured in the BIOS.

COM Port / FPGA Control Registers

A set of registers is located at addresses 0xA50-0xA5F for controlling the enhanced serial port features and for some FPGA control capability. Only two registers from this range should be accessed by the user, as shown in the following table.

<i>Address</i>	<i>Bit</i>	<i>Read/Write</i>	<i>Functional Description</i>
0xA50	0	read-only	COM3 Address Selection, read from jumper J5 – “A”
	1	read-only	COM4 Address Selection, read from jumper J5 – “B”
	2-7	read-only	(unused)
0xA51	0	read/write	COM3 0 = Disable, 1 = Enable
	1	read/write	COM3 : 0 = RS-232, 1 = RS-485
	2	read/write	COM4 0 = Disable, 1 = Enable
	3	read/write	COM4 : 0 = RS-232, 1 = RS-485
	4-7	read/write	(unused, set to 0)
0xA52-0xA5F	0-7	–	(reserved – do not access)

Console Redirection to a Serial Port

In many applications without a video card it may be necessary to obtain keyboard and monitor access to the CPU for configuration, file transfer, or other operations. Hercules II EBX supports this operation by enabling keyboard input and character output onto a serial port, referred to as console redirection. A serial port on another PC can be connected to the serial port on Hercules II EBX with a null modem cable, and a terminal emulation program, such as HyperTerminal, can be used to establish the connection. The terminal program must be capable of transmitting special characters including F2 (some programs or configurations trap special characters).

The default Hercules II EBX BIOS setting enables console redirection onto COM2 during power-on self-test (POST). Communication parameters are 115.2Kbaud, N, 8, 1. When the CPU is powered up, the BIOS outputs POST information to COM2 and monitors the port it for any keyboard activity. You can enter the BIOS by pressing F2 during this time interval. In the default configuration, console redirection is disabled after POST is finished and the CPU boots.

There are three possible configurations for console redirection:

- POST-only (default)
- Always On
- Disabled

To modify the console redirection settings,

1. Enter the BIOS
2. Select the Advanced menu
3. Select Console Redirection.
4. In Com Port Address, select Disabled to disable the function, On-board COM A for COM1, or On-board COM B for COM2 (default).

If you select Disabled, you will not be able to enter BIOS again during power-up through the serial port.

To reenter BIOS when console redirection is disabled, you must either install a PC/104 video board and use a keyboard and terminal or erase the CMOS RAM, which will return the BIOS to its default settings. CMOS RAM may be erased by removing the BAT jumper on the J5 jumper block.

Note: Before erasing CMOS RAM, write down any custom BIOS settings you have made.

If you erase the CMOS RAM, the next time the CPU powers up COM2 returns to the default settings of 115.2Kbaud, N, 8, 1 and operates only during POST.

If you selected COMA or COMB, continue with the configuration, as follows.

1. For Console Type, select PC ANSI.
2. You can modify the baud rate and flow control here if desired.
3. At the bottom, for Continue C.R. after POST, select Off (default) to turn off after POST or select On to remain on always.
4. Exit the BIOS and save your settings.

Watchdog Timer

Hercules II EBX contains a watchdog timer circuit consisting of two programmable timers, WD1 and WD2, cascaded together. The input to the circuit is WDI and the output is WDO. Both signals appear on digital I/O connector J8. WDI may be triggered in hardware or in software. A special “early” version of WDO may be output on the WDO pin. When this signal is connected to WDI, the watchdog circuit is re-triggered automatically. The watchdog timer block diagram is shown in Figure 40.

Figure 40: Watchdog Timer Block Diagram

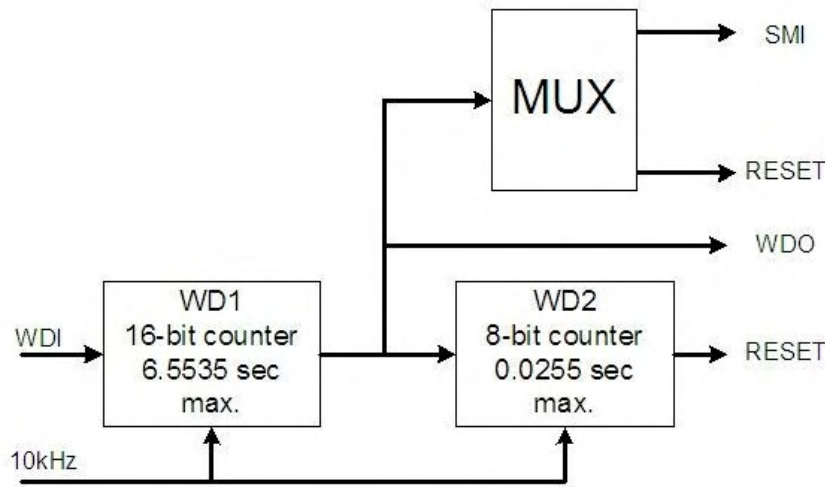

The duration of each timer is user-programmable. When WD1 is triggered, it begins to count down. When it reaches zero, it triggers WD2, sets WDO high, and may also generate a user-selectable combination of the following events.

- System Management interrupt (SMI)
- Hardware reset

WD2 then begins to count down. When the WD2 counter reaches zero, it unconditionally causes a hardware reset. The WD2 timer gives external circuits time to respond to the WDO event before the hardware reset occurs.

The watchdog timer circuit is programmed via I/O registers located on Page 0: Base +28-31. The Hercules II EBX watchdog timer is supported in the Diamond Systems Corporation Universal Driver software version 5.7 and later.

Failsafe Mode and BIOS Recovery

The Hercules II EBX board has the capability to force the BIOS code to be updated on power-up. The board always checks the BIOS for errors at power-up, using an internal CRC code, and may try to force an update if an error is detected. Otherwise, the BIOS can be forced to update by shorting the two *crisis recovery* pads, located just below the J18 connector. If the *crisis recovery* pins are shorted as the board powers-up and enters self-test, the board immediately searches for a USB floppy device on any of the four USB ports. Once a drive is found, the board for a special *crisis recovery* disk, which is provided by Diamond Systems Corporation. If a valid recovery disk is found, the board immediately begins loading and updating the BIOS.

Refer the the BIOS section of this document for a description of the BIOS recovery steps.

Flash Memory

Hercules II EBX contains a 2Mbyte, 16-bit wide flash memory chip for storage of BIOS and other system configuration data.

Backup Battery

Hercules II EBX contains an integrated RTC/CMOS RAM backup battery. The battery is located adjacent to the PC/104 bus connector, J1, and within the PC/104 outline. This battery has a capacity of 120mAH and will last over three years in power-off state. There are also two connection points for alternative, external battery power sources:

- Utility header, J7, pin 12 (V+) and pin 14 (ground)
- External battery header, J20

The external battery should be 3-3.6V and should be able to provide a continuous supply with a nominal 2uA continuous current drain and a peak short-term drain of 1mA. An external battery is only recommended where concern for on-board CMOS settings and/or time accuracy make such redundancy worthwhile.

The on-board battery is activated for the first time during initial factory configuration and test.

System Reset

Hercules II EBX contains a chip to control system reset operation. Reset occurs under the following conditions.

- User causes reset with a ground contact on the *Reset* input.
- Input voltage drops below 4.75V.
- Over-current condition on output power line.

The ISA Reset signal is an active high pulse with a 200ms duration. The PCI Reset is active low, with a typical pulse width duration of 200 msec.

On-Board Video

The on-board video for the Hercules II EBX is based on an S3-TwisterT (VIA 8606 “PN133T” North Bridge) video system. As such, the board memory is shared between the video and main system memory. Using BIOS settings accessible in the BIOS configuration menus, a block of memory is configured for video, which is then removed from use for main system memory. This implies that the more memory used for video, the less memory is available for system resources.

The video memory can be set at 8Mbytes for almost all applications. Increasing the memory size does not increase video performance. Additional memory only benefits the limited 3D support provided by the chipset. Also, the 3D hardware acceleration is not supported across extended temperature ranges. In general, since this 3D hardware is typically used for 3D games, it is unlikely that these limitations will affect most embedded applications.

The low-level BIOS can support LCD output in conjunction with standard RGB output; i.e., dual displays. Similar support for TV output is limited to the OS; the BIOS itself does not directly support the TV Out functionality.

BIOS

Bios Settings

Hercules II EBX uses a BIOS from Phoenix Technologies modified to support the custom board features, which are described below.

To enter the BIOS during system startup, power on self-test (POST), press F2.

Serial Ports

The address and interrupt settings for serial ports COM1/2/3/4 may be modified. COM1 and COM2 address and interrupt settings are set in the *BIOS – Advanced menu – I/O Device Configuration* dialog.

The addresses of COM3 and COM4 are configurable on the board using jumper J5, and are automatically detected by the BIOS. The IRQ selections for COM3 and COM4 are configured using jumper J4. These selections are not automatically detected and must be manually configured in the configuration dialog to match the jumper settings.

IDE Settings

The IDE controller provides two separate IDE channels.

- Primary IDE: This IDE Channel is available via connector J16, a 44-pin laptop-type IDE connector.
- Secondary IDE: This IDE Channel is available via connector J17, a 40-pin, standard UDMA connector.

Note which channel is the primary and which is the secondary, if you are attempting to disable one unused channel in order to free IRQ resources.

32-bit I/O settings can be manually activated for each drive. However, this setting only affects low-level BIOS accesses to the drives when using BIOS system calls, typically under DOS, and may cause system instability for OSs or applications that do not support these types of accesses. For general operation, this does not provide a noticeable performance boost and the setting should be left “disabled” unless absolutely necessary.

LCD Video Settings

The Hercules II EBX provides direct digital support for LVDS-based LCD interfaces only. There are two settings that affect this support during BIOS boot:

- Boot Video Device: By default, this is set to AUTO. With the AUTO setting, the system attempts to identify an RGB monitor, via DDC. If no RGB monitor is detected the system enables LCD support. To use the LCD display regardless of standard monitor connection (i.e., with both connected at once), set *Boot Video Device* to *Both*.
- Panel Type: This setting defaults to 7. Do not alter this setting unless specifically instructed to do so. This setting affects the LCD display modes supported and mode 7 is the only setting currently supported.

Miscellaneous

Unless there is a specific reason to change the *Memory Cache Settings*, it is best to preserve the default settings. Certain system functions, such as USB keyboard support under BIOS menus, may experience a heavy reduction in performance if changes are made to these settings. These cache settings can make a significant difference for low-level BIOS calls and can severely limit performance if they are disabled.

On the Advanced Chipset Control screen, the following settings should be retained.

- Frame Buffer Size: 8MB
- AGP Rate: 4X
- Expansion Bus Performance: Normal

The Frame Buffer size can be increased for specific applications. However, be aware that an increase in this memory size will result in a decrease in overall available system memory. The AGP rate affects internal video accesses and does not affect any external bus speeds.

Expansion Bus Performance is an adjustment to allow an increase in ISA I/O Access speeds. For applications where ISA I/O accesses may be a limiting factor, this performance may be increased to *Accelerated*. Be aware that increasing these timings may adversely affect system stability with external add-on PC/104 cards. This setting has no direct affect on PCI or memory speeds and it only affects ISA PC/104 devices. It is best to leave this parameter set to *Normal* if there are no ISA I/O Performance issues.

On the Advanced screen, the following settings should be retained.

- Installed O/S: Win98
- Large Disk Access Mode: DOS

On the On-Chip Multifunction Device screen, the following settings should be retained.

- USB Device: Enabled
- Legacy Audio: Disabled

Legacy Audio only affects DOS-based applications when used with the VIA-supported DOS Drivers. Enabling this setting requires system I/O, IRQ, and DMA resources. It is strongly recommended that this setting be left *Disabled*.

On the PCI and ISA Configuration pages, from the Advanced screen, the following setting should be retained.

- PCI IRQ Level 1-4: Autoselect for all
- PCI/PNP ISA UMB Region Exclusion: Available for all

The Power Management Screen is only be in effect when under DOS. Otherwise, the OS power management settings pre-empt these settings. The only power management mode supported by the system is *Power-On Suspend*. Other suspend modes are not supported and should not be used under any OS. Examples of unsupported suspend modes are “Hibernate,” under Windows, and “Suspend-to-Disk” or “Suspend-to-RAM”.)

The Memory Shadow page of BIOS options should not be modified without an advanced understanding of these options. These settings can adversely affect system performance and, potentially, system reliability.

BIOS Download / Crisis Recovery

Because the BIOS is stored in reprogrammable Flash memory, it is possible that the BIOS could be accidentally erased when trying to write other files into the Flash. To recover from this situation the CPU chip on Hercules II EBX contains a special failsafe section of ROM code that can be activated on power-up. A Diamond Systems Corporation software utility is provided to enable system recovery by downloading the BIOS to the flash memory through a USB floppy drive when the CPU is booted.

Typically, this *crisis recovery* process is initiated by shorting the “Crisis Recovery” pads on the main board (located just under J18) while powering up the unit. If the board is mounted in such a manner that these pins are not readily accessible, then Crisis Recovery should be initiated by shorting RTS to RI on COM1.

The following sequence describes the *crisis recovery* procedures.

5. Short the Crisis Recovery pads, or RTS and RI on COM1.

<i>PC Serial Port Crisis Recovery (DE-9)</i>
pin 7 (RTS)
pin 9 (RI)

6. Connect a USB Floppy Drive with “Crisis Recovery” floppy disk inserted.
7. Power-up/reset the system. The floppy disk should be accessed; the access light sound of the floppy drive persists for several seconds. If you have a PC speaker attached to the utility header, after a few seconds you should hear a series of beeps.
8. Unshort the Crisis Recovery pads, or the RTS-RI connection, after crisis recovery begins; after the floppy is first accessed or after the first system beep.
9. At the conclusion of the crisis recovery BIOS update, the system beeps and resets.
10. Immediately, enter the BIOS setup screen by pressing F2 from the initial BIOS POST screen.
11. Press F9 to load defaults.
12. While in the BIOS setup menus, reset any non-default settings as needed.
13. Exit the BIOS menus and save the settings.

BIOS COM Port Settings

The BIOS may be used to configure the four COM PORTs. The configuration of COM1/2 is handled differently than COM3/4.

COM1/2 are both located inside the core chipset used for the Hercules II EBX. The configuration procedures are fully configurable in software using BIOS setup screens.

- COM 1 has the following options:
 - ISA I/O Address : 0x3F8 (default), 0x2F8, 0x3E8, or 0x2E8
 - ISA IRQ : IRQ4 (default) or IRQ3
- COM 2 has the following options:
 - ISA I/O Address : 0x2F8 (default), 0x3F8, 0x3E8, or 0x2E8
 - ISA IRQ : IRQ3 (default) or IRQ4
 - Mode : Normal (default), IrDA, ASK_IR

Note: The two IR modes require an external IR transceiver connected to the two IR I/O pins located on connector J7.

COM PORTs 3&4 are handled by an external XR16C2850 UART. The I/O addresses are not configurable in software. Instead, they are determined by the J5 jumper settings. Add or remove a jumper from header location “A” to change COM 3 address or location “B” to change COM 4 address. The BIOS detects these I/O settings and configures the COM3 and COM4 I/O addresses, accordingly.

The IRQ’s for the two COM parts are manually selectable using the J4 jumpers. These settings must still be entered manually into the BIOS to correctly configured the IRQs, and to be reported to the operating system.

The settings for the RS-232 and RS-485 modes of operation for COM3/4 are software-selectable in the BIOS.

<i>COM PORT</i>	<i>ISA I/O address</i>	<i>ISA IRQ</i>	<i>Mode</i>
COM3	0x3E8 (Jumper J5, pin A, NOT jumpered)	IRQ3	RS-232 (default)
	0x2F0 (Jumper J5, pin A, jumpered)	IRQ4	RS-485
		IRQ9	
COM4	0x2E8 (Jumper J5, pin B, NOT jumpered)	IRQ3	RS-232 (default)
	0c3F0 (Jumper J5, pin B, jumpered)	IRQ7	RS-485
		IRQ15	

Note: Jumper J5, pins C3 422 and C4 422 may be used to select RS422, overriding the BIOS settings.

BIOS Console Redirection Settings

For applications where the Video interfaces is not used, the textual feedback typically sent to the monitor can be redirected to a COM PORT. In this way, a system can be managed and booted without a video connection.

The BIOS allows the following configuration options for Console Redirection to a COM PORT:

- COM PORT Address : Disabled (default), COM PORT A, or COM PORT B.

NOTE: If Console Redirection is enabled here, note that the Associated COM PORT (“A” here referring to COM 1 and “B” referring to COM 2) will be enabled, regardless of the COM PORT settings elsewhere.

- Continue CR After POST: Off (default) or On.

This determines if the system is to Wait for CR over COM PORT before continuing (after POST is complete and before the OS starts loading)

- Baud Rate: 19.2K (default), 300, 1200, 2400, 9600, 38.4K, 57.6K, 115.2K.
- Console Connection: Direct (default) or Modem.
- Console Type: PC ANSI (default, VT100, VT100 (8-bit), PC-ANSI (7-bit), VT100+, or VT-UTF8
- Flow Control: CTS/RTS (default), XON-XOFF, None
- Number of video Pages to support: 1(default) to 8

Note: Console Redirection only works for text-based interaction. If the OS enables video and uses direct video functions, which is the case with a Linux X-terminal or Windows, the Console Redirection has no effect and video is required.

System I/O

Ethernet

Hercules II EBX includes a 10/100Mbps Ethernet connection using Cat-5, 100BaseT wiring. The signals are provided on two connectors on the right edge of the board:

<i>Jumper Block</i>	<i>Connector Type</i>
J10	RJ45
J11	6-pin header

The Ethernet chip is the National Semiconductor DP83815 MacPhyter chip, which is connected to the system using the board's internal PCI bus.

The Hercules II EBX Software CD includes Ethernet drivers for Windows 95, Windows 98, Windows NT and Linux. The latest drivers can also be downloaded from National Semiconductor's website at www.national.com. Search for DP83815 to reach the product folder.

A DOS utility program is provided for testing the chip and accessing the configuration EEPROM. Each board is factory-configured with a unique MAC address using the program. To run the program, boot the computer to DOS; do not run the program as a DOS window inside of a Windows OS. In normal operation this program is not needed.

Note: Additional software support includes a packet driver with software to allow a full TCP/IP implementation.

Serial Ports

Hercules II EBX contains four serial ports. Each port is capable of transmitting at speeds up to 115.2Kbaud. Ports COM1 and COM2 are built into the standard chipset, which are standard 16550 UARTs with 16-byte FIFOs.

Ports COM3 and COM4 are derived from an Exar 16C2850 dual UART chip and include 128-byte FIFOs. These ports may be operated at speeds to 1.5Mbaud with installation of high-speed drivers, as a custom option.

The serial ports use the following default system resources.

<i>Port</i>	<i>I/O Address Range</i>	<i>IRQ</i>
COM1	0x3F8 - 0x3FF	4
COM2	0x2F8 - 0x2FF	3
COM3	0x3E8 - 0x3EF	4
COM4	0x2E8 - 0x2EF	3

The COM1 and COM2 settings may be changed in the system BIOS. Select the *Advanced* menu, followed by *I/O Device Configuration*, to modify the base address and interrupt level.

The settings of COM3 and COM4 I/O addresses may be changed using jumpers J5. The jumper settings are auto-detected by the BIOS.

Note: The IRQ settings for COM3 and COM4 are selected using jumper J4. COM3 may use IRQ4 or IRQ9. COM4 may use IRQ3, IRQ7 or IRQ15. Once these jumper selections are made, you must update the serial port IRQ settings to match these selections; the IRQ settings are NOT auto-detected in the way that the address settings are detected.

RS-232 Mode

RS-232 mode is the standard mode for most PC applications. COM1 and COM2 are always RS-232-only, although, there is a product option for RS-485-only. COM3 and COM4 are RS-232 by default and the settings are managed in the BIOS using the *I/O Device Configuration* menu.

RS-232 mode for all four ports provides complete signaling support, including all handshaking signals and the Ring Indicate (RI) signal.

RS-485 Mode

COM3 and COM4 are independently selectable between RS-232 mode (default) and RS-485 mode. If RS-485 mode is selected, special consideration is required to implement RS-485 mode in both hardware and software.

In hardware, the critical issues for RS-485 mode are:

- Receive and transmit only. No handshaking lines are supported.
- Differential signaling; two wires each, high and low, for receive and transmit.
- Signal definitions for connector J18 change depending on the mode for each serial port.

In software, control of the RS-485 transmit line is handled using the serial port RTS signal. Defined as a handshaking signal for RS-232, it is used as a write-control signal for RS-485 operation.

The RS-485 implementation for COM3/4 always receives the data sent. For example, when data is transmitted from COM3, the same data is locally echoed back into the receive buffer of COM3. This allows for data verification to identify RS-485 network collisions; i.e., if another device sends data onto the RS-485 lines at the same time, the data coming into the receive buffer does not match and is not received.

To transmit data for one of these RS-485 ports, the RTS signal must be driven active. The transmitter for that RS-485 port is then active and remains active until the RTS signal is returned to its default, no-transmit, state.

The typical sequence to transmit data on a shared RS-485 cable as follows.

1. Set RTS high to enable transmit.
2. Send data, which is echoed to the receive buffer of the same port.
3. Set RTS low to disable transmit.
4. Verify that data is received and that it matches the transmit data. If the data does not match, re-transmit the data.

RS-422 Mode

COM3 and COM4 are independently selectable to operate in RS-422 mode, instead of RS-232 mode (default) or RS-485 mode. Jumper the J4 connector RS-422 pins to override the BIOS RS-232/RS-485 selection. To operate COM3 in RS-422 mode, jumper J4 pins labeled *C3 422*. To operate COM4 in RS-422 mode, jumper J4 pins labeled *C4 422*.

If RS-422 mode is selected, special hardware and software consideration is required to implement RS-422.

PS/2 Ports

Hercules II EBX supports two PS/2 ports.

- Keyboard
- Mouse

The PS/2 ports are accessible using a cable assembly (DSC#**698022**) attached to connector J6. Support for these ports is independent of, and in addition to, mouse and keyboard support using the USB ports.

USB Ports

Hercules II EBX has eight USB Ports, referred to as USB0 through USB7.

Four USB 1.1 ports, USB0 through USB3, are accessible using cable assemblies attached to connectors J22 and J21. The USB1 port is also available using on-board vertical USB connector J23, located on the top-left corner of the board. Connector J23 should only be used when USB1 on J22 is not used ; otherwise, neither device will operate correctly.

Four USB 2.0 ports, USB4 through USB7, are accessible using cable assemblies attached to connectors J36 and J37.

USB support is intended primarily for the following devices (although any USB-standard device should function).

- Keyboard
- Mouse
- USB Floppy Drive (This is required for Crisis Recovery of boot ROM)
- USB flash disk

The BIOS supports the USB keyboard during BIOS initialization screens and legacy emulation for DOS-based applications.

Note: This feature is only available for USB 1.1 ports (USB Ports 0 to 3).

The USB ports can be used for keyboard and mouse at the same time that the PS/2 keyboard and mouse are connected.

Notes on Operating Systems and Booting Procedures

Windows Operating System Installation Issues

Installation of Windows operating systems (Win98/2000/XP) should follow the sequence described below. Otherwise, some device drivers might not function correctly under Windows.

1. Enable CD-ROM support in the BIOS. Change the boot sequence in the BIOS so the system boots from CD-ROM first.
2. Insert the Windows installation CD into the CD-ROM and restart the computer.
3. Follow the manufacturer's instructions for installing Windows.

Driver Installation

The following steps describe the driver installation procedure.

1. Install the VIA "4-in-1" driver first.

<i>Operating System</i>	<i>Driver Version</i>
Windows 98	v4.35
Windows 2000/XP	v4.40, or later

Normal installation procedures include the following steps

- a. Select from the following four options:
 - VIA ATAPI Vendor Support Driver
 - AGP VxD Driver
 - IRQ Routing Miniport Driver
 - VIA INF Driver v1.40a
 - b. Install the VIA ATAPI Vendor Support Driver.
 - c. Enable DMA Mode.
 - d. Install the VIA AGP VXD in Turbo Mode.
 - e. Install the VIA IRQ Routing Miniport Driver.
2. Install the VIA/S3 Video driver, following the installation instructions.
 3. Install the VIA Sound driver. Ensure that the sound driver is ComboAudio v3.90, or later.
 4. Install the National Semiconductors Network driver.
 5. Load the USB driver for the floppy drive. This driver must be loaded for the USB floppy drive to function under Windows. Legacy support provides floppy access for DOS boot.

BIOS Setting for Windows

When using any version of Windows, the Operating System selection in the BIOS setup menus should be set to Win98. Also, *Legacy Audio* must be disabled for Windows to boot properly.

CompactFlash Under Windows

CompactFlash is not directly supported by Windows 98. A special driver may be available (see the vendor of your specific CompactFlash card for details). Without special drivers, Windows 98 does not recognize the CompactFlash.

CompactFlash support is built into Windows 2000 and XP.

DOS Operating Systems Installation Issues

User the following sequence to install DOS operating systems: MS-DOS, FreeDOS and ROM-DOS.

1. Enable the following in BIOS:
 - Floppy Drive detection.
 - Legacy USB support.
2. Change the BIOS boot sequence so the system boots through the USB floppy drive.
3. Insert the DOS installation floppy disk into the USB floppy drive and start/restart the system.
4. Install any drivers needed.

Notes:

- 1. For DOS Ethernet, set *Operating System* to *other* in the BIOS.**
- 2. DOS Sound emulation is currently not functional.**

CompactFlash Compatibility Issues Under DOS

CompactFlash is incompatible with some utilities, under some versions of DOS.

- CompactFlash with ROM-DOS

The ROM-DOS FDISK utility does not work with CompactFlash drives. The ROM-DOS FORMAT and SYS do work, however. If CompactFlash already has a DOS partition, the ROM-DOS utilities can be used to FORMAT the CompactFlash and install operating system files on CompactFlash.

- CompactFlash with FreeDOS

The FreeDOS FDISK or FORMAT utility do not work with CompactFlash. However, the FreeDOS SYS utility is functional with CompactFlash.

- CompactFlash with MS-DOS

The MS-DOS FDISK, FORMAT, and SYS utilities are not functional when used with CompactFlash. The MS-DOS operating system files cannot be installed on CompactFlash flash.

Data Acquisition Circuit

Hercules II EBX contains a data acquisition subsystem consisting of digital I/O (DIO), watchdog timer (WDC), counter/timer, pulse width modulation (PWM), and optional analog I/O features. The features of a board that includes data acquisition are equivalent to a complete PC/104 add-on data acquisition module.

The A/D section includes a 16-bit A/D converter, 32 input channels and a 2048-sample (4kByte) FIFO. Input ranges are programmable, and the maximum sampling rate is 250 KHz. The D/A section includes four 12-bit D/A channels. The digital I/O section includes 40 lines with programmable direction. The counter/timer section includes a 24-bit counter/timer to control A/D sampling rates and a 16-bit counter/timer for user applications. A 4-channel PWM controller provides a way to automatically generate PWM-based waveforms.

High-speed A/D sampling is supported with interrupts and a FIFO. The FIFO is used to store a user-selected number of samples, and an interrupt is generated when the FIFO reaches this threshold. Once the interrupt occurs, an interrupt service routine reads the data from the FIFO. In this way, the interrupt rate is reduced by a factor equal to the size of the FIFO threshold, enabling a faster A/D sampling rate. In DOS, or similar low-overhead OSs, the circuit can operate at sampling rates of up to 250 KHz.

The interrupt rate, when using high sample-rates, is kept low because of the large FIFO buffer. With a 250 kHz sampling rate and a FIFO threshold of 1024 samples (half-full), the interrupt rate is kept to a reasonable range of approximately 250Hz. Reducing the FIFO interrupt threshold increases the interrupt rate for a given sampling frequency, while increasing the threshold (especially the FIFO full threshold) increases the risk that samples may be lost because of interrupt latency. The interrupt rate is an issue under multitasking OSs, such as Windows, since interrupt handler latency can be significant. For example, operating a serial port at maximum speed (115kbaud) can tax the resources of a system's latency periods, especially when such activity is taking place over the ISA bus, which is the case with both the serial ports and with the A/D FIFO. An interrupt rate of greater than 10 KHz can be difficult to sustain in Windows without losing samples.

The A/D circuit uses the default settings of I/O address range 0x240 – 0x25F (base address 0x240) and IRQ 5. The IRQ setting can be changed if needed using jumper J4.

Figure 41 shows a block diagram of the data acquisition circuit.

Figure 41: Data Acquisition Block Diagram

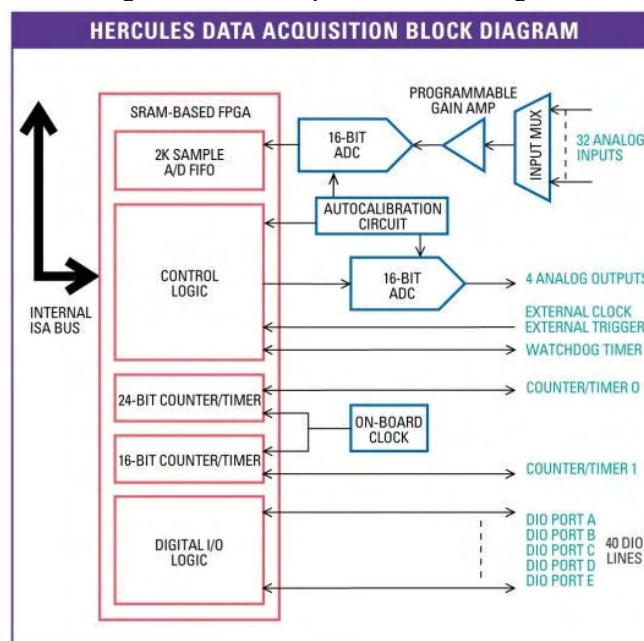

Data Acquisition Circuitry I/O Map

I/O Memory Space

The data acquisition circuitry on Hercules II EBX occupies a block of 32 bytes in I/O memory space. The default address range for this block is 0x240 – 0x24F (base address 0x240).

The address range is a 32-byte block in ISA I/O Space. Within these 32-bytes, the registers are paged to provide full access to additional registers for additional functions; four pages (0-3) are available. Page is configured using the first register of the address space, located at the base address. Byte zero is always present and is mirrored across all four pages so the page register is always available.

NOTE: All data is accurate as of “FPGA Design Specification Revision 1.79”.

The following tables list the register functions and base address offset, for each of the four pages.

<i>Page 0</i>		
<i>Base +</i>	<i>Write Function</i>	<i>Read Function</i>
0	Reset + page register	A/D LSB
1	Analog configuration register	A/D MSB
2	A/D low channel	A/D low channel readback
3	A/D high channel	A/D high channel readback
4	A/D range register	A/D range + status readback
5	D/A channel	-
6	D/A LSB	-
7	D/A MSB	-
8	FIFO threshold LSB	FIFO threshold LSB readback
9	FIFO threshold MSB	FIFO threshold MSB readback
10	-	FIFO depth LSB
11	-	FIFO depth MSB
12	Configuration register	Configuration register readback
13	Operation control register	Operation control register readback
14	-	Operation status register
15	Command register	Hardware config + A/D channel readback
16	DIO port A	DIO port A
17	DIO port B	DIO port B
18	DIO port C	DIO port C
19	DIO port D	DIO port D
20	DIO port E	DIO port E
21	-	-
22	DIO config / bit set	DIO config readback
23	-	-
24	Ctr/timer LSB	Ctr/timer LSB
25	Ctr/timer CSB	Ctr/timer CSB
26	Ctr/timer MSB	Ctr/timer MSB
27	Ctr command/configuration register	-
28	Watchdog timer A LSB	Watchdog timer A LSB
29	Watchdog timer A MSB	Watchdog timer A MSB
30	Watchdog timer B data	Watchdog timer B data
31	Watchdog configuration register	Watchdog config. register readback

<i>Page 1</i>		
<i>Base +</i>	<i>Write Function</i>	<i>Read Function</i>
24	PWM data register LSB	PWM data register LSB
25	PWM data register CSB	PWM data register CSB
26	PWM data register MSB	PWM data register MSB
27	PWM configuration register	-
28	(Autocal) EEPROM/TrimDAC Data	(Autocal) EEPROM/TrimDAC Data
29	(Autocal) EEPROM/TrimDAC Address	(Autocal) EEPROM/TrimDAC Address
30	(Autocal) Calibration Control register	(Autocal) Calibration Status register
31	(Autocal) EEPROM Access Key Register	FPGA Revision Code

<i>Page 2</i>		
<i>Base +</i>	<i>Write Function</i>	<i>Read Function</i>
24	D/A waveform (future)	Feature ID register – A/D
25	D/A waveform (future)	Feature ID register – D/A
26	D/A waveform (future)	Feature ID register – DIO
27	D/A waveform (future)	Feature ID register – Ctr/timers
28	D/A waveform (future)	Device ID register
29	D/A waveform (future)	Device ID register
30	-	-
31	-	-

Note: When pages 1 or 2 are enabled, the page 0 registers at addresses 0-23 are still accessible.

Page 3 is a 27-byte page occupying locations 1-27 of the chip, and contains a copyright notice in ASCII format.

In page 3, the RESET command and page register at base + 0 are accessible, so the chip may be reset or the page changed.

I/O Register Map Bit Assignments

Note: In the tables below, blank bits are not used. Writes to a blank bit have no effect. Reads of a blank bit return the value zero.

Page 0 Write

Base +	7	6	5	4	3	2	1	0
0	HOLDOFF	RESET	-	-	-	-	PAGE1	PAGE0
1	-	-	-	-	-	DABU	SEDIFF	ADBU
2	-	-	-	L4	L3	L2	L1	L0
3	-	-	-	H4	H3	H2	H1	H0
4	LDAD	-	-	-	-	-	G1	G0
5	SU	-	-	-	-	-	DACH1	DACH0
6	DA7	DA6	DA5	DA4	DA3	DA2	DA1	DA0
7	-	-	-	-	DA11	DA10	DA9	DA8
8	FT7	FT6	FT5	FT4	FT3	FT2	FT1	FT0
9	-	-	-	-	FT11	FT10	FT9	FT8
10	-	-	-	-	-	-	-	-
11	-	-	-	-	-	-	-	-
12	LED	SINGLE	DIOCTR1	DIOCTR0	SCINT	CLKSRC1	CLKFRQ1	CLQFRQ0
13	-	TINTE	DINTE	AINTE	FIFOEN	SCANEN	CLKSEL	CLKEN
14	-	-	-	-	-	-	-	-
15	-	-	FIFORST	DARST	CLRT	CLRD	CLRA	ADSTART
16	DIOA7	DIOA6	DIOA5	DIOA4	DIOA3	DIOA2	DIOA1	DIOA0
17	DIOB7	DIOB6	DIOB5	DIOB4	DIOB3	DIOB2	DIOB1	DIOB0
18	DIOC7	DIOC6	DIOC5	DIOC4	DIOC3	DIOC2	DIOC1	DIOC0
19	DIOD7	DIOD6	DIOD5	DIOD4	DIOD3	DIOD2	DIOD1	DIOD0
20	DIOE7	DIOE6	DIOE5	DIOE4	DIOE3	DIOE2	DIOE1	DIOE0
21	-	-	-	-	-	-	-	-
22	MODE	P2	P1	PO/DIRE	B2/DIRD	B1/DIRC	B0/DIRB	D/DIRA
23	-	-	-	-	-	-	-	-
24	CTRD7	CTRD6	CTRD5	CTRD4	CTRD3	CTRD2	CTRD1	CTRD0
25	CTRD15	CTRD14	CTRD13	CTRD12	CTRD11	CTRD10	CTRD9	CTRD8
26	CTRD23	CTRD22	CTRD21	CTRD20	CTRD19	CTRD18	CTRD17	CTRD16
27	CTR	LATCH	CTDIS	GTEN	CTDIS	CTEN	LOAD	CLR
28	WDA7	WDA6	WDA5	WDA4	WDA3	WDA2	WDA1	WDA0
29	WDA15	WDA14	WDA13	WDA12	WDA11	WDA10	WDA9	WDA8
30	WDB7	WDB6	WDB5	WDB4	WDB3	WDB2	WDB1	WDB0
31	WDTRIG	-	WDEN	WDSMI	WDRST	WDT-1	WDEDGE	WDIEN

Page 0 Read

Base +	7	6	5	4	3	2	1	0
0	AD7	AD6	AD5	AD4	AD3	AD2	AD1	AD0
1	AD15	AD14	AD13	AD12	AD11	AD10	AD9	AD8
2	-	-	-	L4	L3	L2	L1	L0
3	-	-	-	H4	H3	H2	H1	H0
4	ADBUSY	WAIT	DABUSY	DABU	SEDIFF	ADBU	G1	G0
5	-	-	-	-	-	-	-	-
6	-	-	-	-	-	-	-	-
7	-	-	-	-	-	-	-	-
8	FT7	FT6	FT5	FT4	FT3	FT2	FT1	FT0
9	-	-	-	-	FT11	FT10	FT9	FT8
10	FD7	FD6	FD5	FD4	FD3	FD2	FD1	FD0
11	-	-	-	FD12	FD11	FD10	FD9	FD8
12	LED	SINGLE	DIOCTR1	DIOCTR0	SCINT	CLKSRC1	CLKFRQ1	CLQFRQ0
13	-	TINTE	DINTE	AINTE	FIFOEN	SCANEN	CLKSEL	CLKEN
14	-	TINT	DINT	AINTE	OVF	FF	TF	EF
15	CFG1	CFG0	-	ADCH4	ADCH3	ADCH2	ADCH1	ADCH0
16	DIOA7	DIOA6	DIOA5	DIOA4	DIOA3	DIOA2	DIOA1	DIOA0
17	DIOB7	DIOB6	DIOB5	DIOB4	DIOB3	DIOB2	DIOB1	DIOB0
18	DIOC7	DIOC6	DIOC5	DIOC4	DIOC3	DIOC2	DIOC1	DIOC0
19	DIOD7	DIOD6	DIOD5	DIOD4	DIOD3	DIOD2	DIOD1	DIOD0
20	DIOE7	DIOE6	DIOE5	DIOE4	DIOE3	DIOE2	DIOE1	DIOE0
21	-	-	-	-	-	-	-	-
22	-	-	-	DIRE	DIRD	DIRC	DIRB	DIRA
23	-	-	-	-	-	-	-	-
24	CTRD7	CTRD6	CTRD5	CTRD4	CTRD3	CTRD2	CTRD1	CTRD0
25	CTRD15	CTRD14	CTRD13	CTRD12	CTRD11	CTRD10	CTRD9	CTRD8
26	CTRD23	CTRD22	CTRD21	CTRD20	CTRD19	CTRD18	CTRD17	CTRD16
27	-	-	-	-	-	-	-	-
28	WDA7	WDA6	WDA5	WDA4	WDA3	WDA2	WDA1	WDA0
29	WDA15	WDA14	WDA13	WDA12	WDA11	WDA10	WDA9	WDA8
30	WDB7	WDB6	WDB5	WDB4	WDB3	WDB2	WDB1	WDB0
31	-	-	-	-	-	-	-	-

Page 1 Write

Offsets base+28, +29 and +31 refer to EEPROM Data, address, and unlock command registers for auto-calibration.

Base +	7	6	5	4	3	2	1	0
0	HOLDOFF	RESET	-	-	-	-	PAGE1	PAGE0
24	-	-	-	-	-	-	-	-
25	-	-	-	-	-	-	-	-
26	-	-	-	-	-	-	-	-
27	-	-	-	-	-	-	-	-
28	D7	D6	D5	D4	D3	D2	D1	D0
29	-	A6	A5	A4	A3	A2	A1	A0
30	EE_EN	EE_RW	RUNCAL	CMUXEN	TDACEN	-	-	-
31	-	-	-	-	-	-	-	-

Page 1 Read

Offset base+31 is the FPGA revision code (0x40).

Base +	7	6	5	4	3	2	1	0
0	-	-	-	-	-	-	-	-
24	PWMD7	PWMD6	PWMD5	PWMD4	PWMD3	PWMD2	PWMD1	PWMD0
25	PWMD15	PWMD14	PWMD13	PWMD12	PWMD11	PWMD10	PWMD9	PWMD8
26	PWMD23	PWMD22	PWMD21	PWMD20	PWMD19	PWMD18	PWMD17	PWMD16
27	-	-	-	-	-	-	-	-
28	D7	D6	D5	D4	D3	D2	D1	D0
29	-	A6	A5	A4	A3	A2	A1	A0
30	0	TDBUSE	EEBUSY	CMUXEN	0	0	0	0
31	-	-	-	-	-	-	-	-

Page 2 Write

Offsets base+24 through base+31 are reserved for a future D/A waveform generator circuit.

Base +	7	6	5	4	3	2	1	0
0	HOLDOFF	RESET	-	-	-	-	PAGE1	PAGE0
24	-	-	-	-	-	-	-	-
25	-	-	-	-	-	-	-	-
26	-	-	-	-	-	-	-	-
27	-	-	-	-	-	-	-	-
28	-	-	-	-	-	-	-	-
29	-	-	-	-	-	-	-	-
30	-	-	-	-	-	-	-	-
31	-	-	-	-	-	-	-	-

Page 2 Read

Base +	7	6	5	4	3	2	1	0
0	-	-	-	-	-	-	-	-
24	ADQ7	ADQ6	ADQ5	ADQ4	ADQ3	ADQ2	ADQ1	ADQ0
25	FDID2	FDID1	FDID0	DAQ4	DAQ3	DAQ2	DAQ1	DAQ0
26	DIOQ7	DIOQ6	DIOQ5	DIOQ4	DIOQ3	DIOQ2	DIOQ1	DIOQ0
27	PWMQ3	PWMQ2	PWMQ1	PWMQ0	CTRQ3	CTRQ2	CTRQ1	CTRQ0
28	ID7	ID6	ID5	ID4	ID3	ID2	ID1	ID0
29	ID15	ID14	ID13	ID12	ID11	ID10	ID9	ID8
30	-	-	-	-	-	-	-	-
31	-	-	-	-	-	-	-	-

I/O Register Definitions

Page 0 Register Definitions

Page Select and Reset Command: Base+0 (Write)

Bit:	7	6	5	4	3	2	1	0
Name:	HOLDOFF	RESET	-	-	-	-	PAGE	

HOLDOFF When this bit is set, the chip ignores any data written to this register. This bit enables shadowing this register with another device at the same address.

RESET Reset the entire data acquisition circuit. After a reset, the following conditions are true:

- Digital I/O ports are set to input mode and all output registers are cleared to 0.
- A/D channel registers and range settings are cleared to zero, except for the Analog Configuration Register (Base+1) which is set to 0x04.
- D/A channels are cleared to mid-scale or zero-scale, depending on the board jumper setting.
- Counter/timers are disabled and counter registers are cleared to zero.
- Watchdog timer is disabled and timer registers are cleared to zero.
- FIFO is reset, causing all contents to be lost, and threshold is set to 1024 samples.
- The internal channel / gain table is reset to all zeros.

PAGE Select page.
0 = Main features page
1 = Extended features page
2 = ID page
3 = Copyright notice page

A/D LSB: Base+0 (Read)

Bit:	7	6	5	4	3	2	1	0
Name:	AD7	AD6	AD5	AD4	AD3	AD2	AD1	AD0

AD7-AD0 A/D LSB data. The A/D data must be read LSB first, followed by MSB.

Analog Configuration: Base+1 (Write)

Bit:	7	6	5	4	3	2	1	0
Name:	-	-	-	-	-	DABU	SEDIFF	ADBU

DABU D/A output range: 0 = bipolar, 1 = unipolar. (Default on reset is unipolar mode).

SEDIFF A/D mode: 0 = single-ended, 1 = differential.

ADBU A/D input range: 0 = bipolar, 1 = unipolar.

A/D MSB: Base+1 (Read)

Bit:	7	6	5	4	3	2	1	0
Name:	AD15	AD14	AD13	AD12	AD11	AD10	AD9	AD8

AD15-AD8 A/D MSB data. The A/D data must be read LSB first, followed by MSB.

A/D Low Channel: Base+2 (Read/Write)

Bit:	7	6	5	4	3	2	1	0
Name:	-	-	-	L4	L3	L2	L1	L0

L4-L0 A/D low channel number.

A/D High Channel: Base+3 (Read/Write)

Bit:	7	6	5	4	3	2	1	0
Name:	-	-	-	H4	H3	H2	H1	H0

H4-H0 A/D high channel number.

A/D Input Range Control: Base+4 (Write)

Bit:	7	6	5	4	3	2	1	0
Name:	LDAD	-	-	-	-	-	G(1/0)	

LDAD The FPGA contains a global input range setting as well as a 32x4 table for all 32 input channels that can be used for individual input ranges, for each channel. The chip uses either the global input range setting or the individual range table, based on the setting of the SINGLE bit in register Base+12.

If this bit is set (1), the remaining bits are stored as the individual input range for the A/D channel currently set by L4-L0 in register Base+2. If this bit is reset (0), the remaining bits are the global setting for all input channels.

G(1/0) Gain: The gain is the ratio between the input voltage and the voltage seen by the A/D converter. The A/D always works with a maximum input voltage of 10V. A gain of 2 means the maximum input voltage at the connector pin is 5V.

0 = gain of 1

1 = gain of 2

2 = gain of 4

3 = gain of 8

A/D Range/Status Readback: Base+4 (Read)

Bit:	7	6	5	4	3	2	1	0
Name:	ADBUSY	WAIT	DABUSY	DABU	SEDIFF	ADBU	G(1/0)	

ADBUSY 0 = A/D is idle and data may be read out.

1 = A/D is performing an A/D conversion.

WAIT 0 = A/D circuit is ready to perform an A/D conversion.

1 = A/D circuit is settling on a new channel or gain setting. The program must not initiate an A/D conversion while WAIT = 1.

DABUSY 0 = D/A circuit is idle / D/A output is stable.

1 = D/A circuit is transferring data to the D/A chip after writing data to the board.

DABU 0 = bipolar.

1 = unipolar D/A output range.

SEDIFF 0 = single-ended.

1 = differential A/D mode.

ADBU 0 = bipolar.

1 = unipolar A/D input range.

G(1/0) Readback of global A/D gain setting. The individual A/D gain settings may not be read back.

D/A Channel: Base+5 (Write)

Bit:	7	6	5	4	3	2	1	0
Name:	SU	-	-	-	-	-	DACH(1/0)	

SU Simultaneous Update:

0 = Transparent (written directly to the DAC's)/Simultaneous write.

1 = Latch and hold data (DAC output not updated until "0" is written later).

DACH(1/0) D/A channel number.

Note: Writing to this register updates the selected D/A channel with the data currently stored in registers Base+6 and Base+7. The high-order bit determines if the data is transferred directly out to the DAC's (transparent mode) or is latched and held for a later simultaneous update.

D/A LSB: Base+6 (Write)

Bit:	7	6	5	4	3	2	1	0
Name:	DA7-DA0							

DA7-DA0 D/A LSB data.

D/A MSB: Base+7 (Write)

Bit:	7	6	5	4	3	2	1	0
Name:	DA15-DA8							

DA15-DA8 D/A MSB data.

FIFO Threshold LSB: Base+8 (Read/Write)

Bit:	7	6	5	4	3	2	1	0
Name:	FT7-FT0							

FT7-FT0 FIFO threshold value LSB.

FIFO Threshold MSB: Base+9 (Read/Write)

Bit:	7	6	5	4	3	2	1	0
Name:	-	-	-	-	-	FT10-FT8		

FT10-FT8 FIFO threshold value MSB.

When the FIFO depth is greater than or equal to the FIFO threshold, TF (threshold flag) = 1 and an A/D interrupt request will be generated, if FIFOEN = 1 and ADINTE = 1.

The FIFO size is 2048 samples. The threshold value may be anywhere from 1 to 2047 samples. In most cases, the threshold does not need to be larger than one-half the FIFO size, or 1024 samples.

On power-up or system reset, the FIFO threshold is set to 1024 samples.

FIFO Depth LSB: Base+10 (Read)

Bit:	7	6	5	4	3	2	1	0
Name:	FD7-FD0							

FD7-FD0 Current FIFO depth LSB.

FIFO Depth MSB: Base+11 (Read)

Bit:	7	6	5	4	3	2	1	0
Name:	-	-	-	FD12-FD8				

FD12-FD8 Current FIFO depth MSB.

The FIFO depth registers indicates the current depth, or number of bytes, in the FIFO. The depth is reset to 0 when a FIFORST command occurs. It increments by one each time a byte from the A/D converter is inserted into the FIFO and decrements by one each time a byte is read from the FIFO. FD, therefore, increments/decrements by two for a full A/D sample write or read operation. If a 16-bit read operation occurs, FD decrements by 2 after the operation.

Configuration: Base+12 (Read/Write)

Bit:	7	6	5	4	3	2	1	0
Name:	LED	SINGLE	DIOCTR1	DIOCTR0	SCINT	CLKSRC1	CLKFRQ1	CLKFRQ0

LED Active high, a simple status bit used to drive external LED. Default is high upon power-up.

SINGLE Indicates whether to use the global A/D input range or the individual input range table for A/D conversions.

0 = use global setting for all channels.

1 = use the programmed settings for each channel.

DIOCTR1 I/O connector DIOE7-4 pins signal selection:

0 = digital I/O lines DIOE7-4 appear on DIOE7-4 pins of I/O connectors.

1 = counter signals appear on DIOE7-4 pins of I/O connectors.

DIOCTR0 I/O connector DIOE3-0 pins signal selection:

0 = digital I/O lines DIOE3-0 appear on DIOE3-0 pins of I/O connectors.

1 = PWM signals appear on DIOE3-0 pins of I/O connectors.

SCINT A/D scan interval selection:

0 = 4 μ S

1 = 9 μ S

CLKSRC1 Clock source for counter 1:

0 = internal (see CLKFRQ1 below).

1 = external (J8, pin 41, EXTTRIG).

CLKFRQ1 Internal clock frequency for counter 1:

0 = 10MHz

1 = 100 KHz

CLKFRQ0 Internal clock frequency for counter 0:

0 = 10MHz

1 = 100 KHz

Operation Control: Base+13 (Read/Write)

Bit:	7	6	5	4	3	2	1	0
Name:		TINTE	DINTE	AINTE	FIFOEN	SCANEN	CLKSEL	CLKEN

- TINTE** Timer interrupt enable (Only one of the TINTE/DINTE/AINTE interrupts may be enabled at a time):
0 = disabled
1 = enabled
- DINTE** Digital I/O interrupt enable (Only one of the TINTE/DINTE/AINTE interrupts may be enabled at a time):
0 = disabled
1 = enabled
- AINTE** A/D interrupt enable (Only one of the TINTE/DINTE/AINTE interrupts may be enabled at a time):
0 = disabled
1 = enabled
- FIFOEN** FIFO enable. When the FIFOEN = 1 and AINTE = 1, A/D interrupts occur when the FIFO reaches its programmed threshold set with FT11-0. When FIFOEN = 0 and AINTE = 1, A/D interrupts occur according to the following conditions: a) if SCANEN = 1, the interrupt occurs at the end of the scan, and the FIFO contains all the samples of the scan; b) if SCANEN = 0, the interrupt occurs after each single A/D conversion.
0 = disabled
1 = enabled
- SCANEN** A/D Scan enable. When SCANEN = 1, the A/D circuit performs a complete scan of all channels between the low and high channels, inclusive, with each trigger.
0 = disabled
1 = enabled
- CLKSEL** A/D hardware clock enable. When CLKEN = 1, the A/D circuit is triggered by the hardware clock selected with CLKSEL below, and the software A/D trigger is disabled.
0 = disabled
1 = enabled
- CLKEN** A/D hardware clock select (only applies when CLKEN = 1):
0 = rising edge of counter/timer 0.
1 = falling edge on external trigger from I/O connector.

Operation Status: Base+14 (Read)

Bit:	7	6	5	4	3	2	1	0
Name:	-	TINT	DINT	AINT	OVF	FF	TF	EF

- TINT** Timer interrupt status:
1 = interrupt pending
0 = no interrupt pending
- DINT** Digital I/O interrupt status:
1 = interrupt pending
0 = no interrupt pending
- AINT** A/D interrupt status:
1 = interrupt pending
0 = no interrupt pending
- OVF** FIFO overflow flag. Overflow occurs when the FIFO is full and an A/D conversion occurs. If OVF is set, it will stay set until the FIFO is reset with a FIFORST command.
0 = no overflow
1 = overflow
- FF** FIFO full flag:
0 = FIFO is not full
1 = FIFO is full
- TF** FIFO threshold flag:
0 = FIFO depth is below the programmed threshold
1 = FIFO depth is at or above the programmed threshold
- EF** FIFO empty flag:
0 = not empty
1 = empty

Command: Base+15 (Write)

Bit:	7	6	5	4	3	2	1	0
Name:	-	-	FIFORST	DARST	CLRT	CLRD	CLRA	ADSTART

- FIFORST** Reset the FIFO. After this command, OVF, FF, and TF = 0, and EF = 1.
- DARST** Reset the D/A. All D/A channels are reset to zero-scale.
- CLRT** Clear timer interrupt request.
- CLRD** Clear digital I/O interrupt request.
- CLRA** Clear A/D interrupt request.
- ADSTART** Start an A/D conversion. After this command, ADBUSY = 1, until the A/D conversion is finished.

Each bit in this register represents a command. Writing a 1 to any bit executes the command specified by that bit. Only one bit may be written at a time.

Hardware Configuration and A/D Channel Readback: Base+15 (Read)

Bit:	7	6	5	4	3	2	1	0
Name:	CFG(1/0)		-	ADCH4-0				

CFG(1/0) These bits report the logic level of two input pins on the logic chip that can be used to indicate the board's hardware configuration. The current, default value is "11".

ADCH4-0 Current A/D channel. This is the channel sampled on the next A/D conversion.

Digital I/O Port A: Base+16 (Read/Write)

Bit:	7	6	5	4	3	2	1	0
Name:	DIOA7-0							

DIOA7-0 Port A DIO data.

Digital I/O Port B: Base+17 (Read/Write)

Bit:	7	6	5	4	3	2	1	0
Name:	DIOB7-0							

DIOB7-0 Port B DIO data.

Digital I/O Port C: Base+18 (Read/Write)

Bit:	7	6	5	4	3	2	1	0
Name:	DIOC7-0							

DIOC7-0 Port C DIO data.

Digital I/O Port D: Base+19 (Read/Write)

Bit:	7	6	5	4	3	2	1	0
Name:	DIOD7-0							

DIOD7-0 Port D DIO data.

Digital I/O Port E: Base+20 (Read/Write)

Bit:	7	6	5	4	3	2	1	0
Name:	DIOE7-0							

DIOE7-0 Port E DIO data. Port E shares device pins with 4 counter/timer signals and 4 PWM outputs. The function of these two groups of four pins is controlled with register bits DIOCTR1 and DIOCTR0.

DIOCTR1:

0 = digital I/O lines DIOE7-4 appear on DIOE7-4 pins of I/O connectors.

1 = counter signals appear on DIOE7-4 pins of I/O connectors.

DIOCTR0:

0 = digital I/O lines DIOE3-0 appear on DIOE3-0 pins of I/O connectors.

1 = PWM signals appear on DIOE3-0 pins of I/O connectors.

(See register Base+12, Configuration Register, for details).

Digital I/O Configuration / Bit Programming: Base+22 (Write)

Bit:	7	6	5	4	3	2	1	0
Name:	MODE	P2-P0			B2-B0			D
		-	-	DIRE-A				

MODE Indicates port direction or bit programming mode:

0 = port direction; provides a quick way to program individual digital I/O bits.

1 = bit programming; used to configure the direction of the digital I/O ports.

P2-P0 (MODE = 0)

Port number:

0 = A

1 = B

2 = C

3 = D

B2-B0 (MODE = 0)

Bit number, 0-7.

D (MODE = 0)

Bit value, 0 or 1.

DIRE-A (MODE = 1)

Direction for ports A – E. On power-up or system reset, all ports are set to input mode and the contents of the output registers are set to 0.

0 = input

1 = output

Note: Counter/timer 0 is 24 bits wide and uses all three of the following registers. Counter/timer 1 is 16 bits wide and uses only registers 24 and 25. The bytes may be written and read in any order.

Counter/Timer Data Byte 1: Base+24 (Read/Write)

Bit:	7	6	5	4	3	2	1	0
Name:	CTRD7-0							

CTRD7-0 LSB for counter/timers 0 and 1.

Counter/Timer Data Byte 2: Base+25 (Read/Write)

Bit:	7	6	5	4	3	2	1	0
Name:	CTRD15-8							

CTRD15-8 CSB (middle byte) for counter/timer 0, MSB for counter/timer 1.

Counter/Timer Data Byte 3: Base+26 (Read/Write)

Bit:	7	6	5	4	3	2	1	0
Name:	CTRD23-16							

CTRD23-16 MSB for counter/timer 0.

Counter/Timer Control: Base+27 (Write)

Bit:	7	6	5	4	3	2	1	0
Name:	CTR	LATCH	GTDIS	GTEN	CTDIS	CTEN	LOAD	CLEAR

- CTR Counter number, 0 or 1.
- LATCDH Latch selected counter's current data into bytes 1-3 or 1-2, as appropriate.
- GTDIS Disable gating on selected counter.
- GTEN Enable gating on selected counter.
- CTDIS Disable counting on selected counter.
- CTEN Enable counting on selected counter.
- LOAD Load selected counter with data in bytes 1-3 or 1-2, as appropriate.
- CLEAR Clear selected counter to zero.

Watchdog Timer A LSB Data: Base+28 (Read/Write)

Bit:	7	6	5	4	3	2	1	0
Name:	WDA7-0							

WDA7-0 LSB of timer A divisor. Loading occurs for both bytes when the MSB is written.

Watchdog Timer A MSB Data: Base+29 (Read/Write)

Bit:	7	6	5	4	3	2	1	0
Name:	WDA15-8							

WDA15-8 MSB of timer A divisor. Loading occurs for both bytes when the MSB is written.

Watchdog Timer B Data: Base+30 (Read/Write)

Bit:	7	6	5	4	3	2	1	0
Name:	WDB7-0							

WDB7-0 Watchdog timer B data register. Loading occurs immediately upon writing to this register.

Watchdog Timer Configuration: Base+31 (Read/Write)

Bit:	7	6	5	4	3	2	1	0
Name:	WDTRIG	-	WDEN	WDSMI	WDRST	WDT-1	WDEDGE	WDIEN

WDTRIG If this bit is set (1), the remaining bits of this register are ignored and, instead, watchdog timer A is retriggered; i.e. reloaded with its initial value. If this bit is reset (0), the remaining bits in this register are used to configure the watchdog timer circuit.

WDEN Enable watchdog timer circuit:
0 = disabled
1 = enabled

WDSMI Enable SMI interrupt upon watchdog timer timeout.

WDRST Enable system reset upon watchdog timer timeout (setting this clears WDSMI).

WDT-1 Enable output pulse from timer A 1 clock early on WDO pin of I/O connectors. This allows WDO to be connected to WDI to prevent watchdog timer timeout as long as the timer is running.

WDEDGE Select active edge for hardware (external) retrigger:
0 = rising edge.
1 = falling edge.

WDIEN Enable external input hardware watchdog trigger instead of on-board software trigger.
0 = internal trigger only.
1 = external trigger plus internal trigger are enabled.

Page Select and Reset Command: Base+0 (Write)

Bit:	7	6	5	4	3	2	1	0
Name:	HOLDOFF	RESET	-	-	-	-	PAGE	

HOLDOFF When this bit is set, the chip ignores any data written to this register. This bit enables shadowing this register with another device at the same address.

RESET Reset the entire data acquisition circuit. After a reset, the following conditions are true:

- Digital I/O ports are set to input mode and all output registers are cleared to 0.
- A/D channel registers and range settings are cleared to zero, except for the Analog Configuration Register (Base+1) which is set to 0x04.
- D/A channels are cleared to mid-scale or zero-scale, depending on the board jumper setting.
- Counter/timers are disabled and counter registers are cleared to zero.
- Watchdog timer is disabled and timer registers are cleared to zero.
- FIFO is reset, causing all contents to be lost, and threshold is set to 1024 samples.
- The internal channel / gain table is reset to all zeros.

PAGE Select page.
 0 = Main features page
 1 = Extended features page
 2 = ID page
 3 = Copyright notice page

PWM Data LSB: Base+24 (Write)

Bit:	7	6	5	4	3	2	1	0
Name:	PWMD7-0							

PWMD7-0 PWM data bits 7-0.

PWM Data CSB: Base+25 (Write)

Bit:	7	6	5	4	3	2	1	0
Name:	PWMD15-8							

PWMD15-8 PWM data bits 15-8.

PWM Data MSB: Base+26 (Write)

Bit:	7	6	5	4	3	2	1	0
Name:	PWMD23-16							

PWMD23-16 PWM data bits 23-16.

PWM Command: Base+27 (Write)

Bit:	7	6	5	4	3	2	1	0
Name:	FLAG	RSVD	PWM(1/0)		0/CLK	0/POL	0/OUTEN	CTR/ENA

FLAG Command/configuration flag:

0 = command

1 = configuration

RSVD (reserved for future use)

PWM(1/0) Indicates which of the four PWM circuits to access.

CLK If FLAG = 0, value of bits 1-3 are zero, which is the load counter command.

If FLAG = 1, selects internal clock source for both PWM counters:

0 = 10MHz

1 = 100 KHz

POL If FLAG = 0, value of bits 1-3 are zero, which is the load counter command.

If FLAG = 1, selects polarity of output pulse (active level):

0 = active low level

1 = active high level

OUTEN If FLAG = 0, value of bits 1-3 are zero, which is the load counter command.

If FLAG = 1, output enable:

0 = disabled (output held at inactive level based on setting of POL bit)

1 = enabled

CTR/ENA If FLAG = 0, indicates which counter to act on:

0 = rate counter.

1 = duty cycle counter.

If FLAG = 1,

0 = disabled

1 = running

EEPROM/TrimDAC Data: Base+28 (Read/Write)

Bit:	7	6	5	4	3	2	1	0
Name:	D7-0							

D7-0 Calibration data to be read or written to the EEPROM and/or TrimDAC. During EEPROM or TrimDAC *write* operations, the data written to this register is written to the selected device. During EEPROM *read* operations this register contains the data read from the EEPROM, which is valid only after EEBUSY = 0.
The EEPROM data can be read and written. The TrimDAC data can only be written.

EEPROM / TrimDAC Address: Base+29 (Read/Write)

Bit:	7	6	5	4	3	2	1	0
Name:	A7-0							

A7-0 EEPROM / TrimDAC address. The EEPROM recognizes address 0 – 255 using address bits A7 – A0. The TrimDAC recognizes addresses 0 – 7 using bits A2 – A0. In each case, unused address bits are ignored.
Current implementations of FPGA/Data Acquisition storage only use the lower 128 bytes of EEPROM data (addresses 0-127). The remaining 128 bytes (addresses 128-255) are available for general use.

Calibration Control: Base+30 (Write)

Bit:	7	6	5	4	3	2	1	0
Name:	EE_EN	EE_RW	RUNCAL	CMUXEN	TDACEN	-	-	-

EE_EN EEPROM Enable. Setting this bit initiates a transfer to/from the EEPROM; the direction is indicated by the EE_RW bit. However if TDACEN is set simultaneously, EE_EN is ignored.

EE_RW Selects read or write operation for the EEPROM:

0 = Write

1 = Read

RUNCAL Setting this bit causes the board to reload the calibration settings from EEPROM registers 0-7 into the eight TrimDACs. which is equivalent to a “reload” operation. During reload operation, TDBUSY = 1.

CMUXEN Calibration multiplexer enable. The CMUXEN bit is used to enable calibration mode. After calibration is complete, CMUXEN is reset and the desired configuration is restored. The calibration multiplexer is used to read precision on-board reference voltages that are used in the auto-calibration process. It also can be used to read the value of analog output 0.

0 = disable calibration multiplexer, enable user inputs.

1 = enable calibration multiplexer and disable user analog input channels/muxes.

TDACEN TrimDAC Enable. Setting this bit will initiates a transfer to the TrimDAC. This bit overrides the EE_EN setting; if both bits are set simultaneously, EE_EN is ignored.

Calibration Status: Base+30 (Read)

Bit:	7	6	5	4	3	2	1	0
Name:	0	TDBUSY	EEBUSY	CMUXEN	0	0	0	0

TDBUSY TrimDAC busy indicator:

0 = User may access TrimDAC.

1 = TrimDAC is being accessed or reload operation is in progress.

EEBUSY EEPROM busy indicator:

0 = User may access EEPROM.

1 = EEPROM is being accessed.

CMUXEN Calibration multiplexer enable status.

0 = disabled

1 = enabled

Note: When either TDBUSY or EEBUSY is set, do not access the data and address registers at Base+12 and Base+13.

EEPROM Access Key: Base+31 (Write)

Bit:	7	6	5	4	3	2	1	0
Name:	EEPROM Access Key							

EEPROM To access the EEPROM, write the value 0xA5 (10100101) to this register each time, after setting the Access Key PAGE bit in order. This helps prevent accidental corruption of EEPROM contents.

FPGA Revision Code: Base+31 (Read)

Bit:	7	6	5	4	3	2	1	0
Name:	FPGA Revision Code							

FPGA Revision Code This register indicates the revision number of the FPGA design. The current revision code is 0x40.

Page Select and Reset Command: Base+0 (Write)

Bit:	7	6	5	4	3	2	1	0
Name:	HOLDOFF	RESET	-	-	-	-	PAGE	

HOLDOFF When this bit is set, the chip ignores any data written to this register. This bit enables shadowing this register with another device at the same address.

RESET Reset the entire data acquisition circuit. After a reset, the following conditions are true:

- Digital I/O ports are set to input mode and all output registers are cleared to 0.
- A/D channel registers and range settings are cleared to zero, except for the Analog Configuration Register (Base+1) which is set to 0x04.
- D/A channels are cleared to mid-scale or zero-scale, depending on the board jumper setting.
- Counter/timers are disabled and counter registers are cleared to zero.
- Watchdog timer is disabled and timer registers are cleared to zero.
- FIFO is reset, causing all contents to be lost, and threshold is set to 1024 samples.
- The internal channel / gain table is reset to all zeros.

PAGE Select page.
 0 = Main features page
 1 = Extended features page
 2 = ID page
 3 = Copyright notice page

A/D Feature ID: Base+24 (Read)

Bit:	7	6	5	4	3	2	1	0
Name:	ADQ7-0							

ADQ7-0 Indicates the number of A/D channels available on the board.

D/A Feature ID & FIFO Depth ID: Base+25 (Read)

Bit:	7	6	5	4	3	2	1	0
Name:	FDID2-0				DAQ4-0			

FDID2-0 Indicates the maximum sample depth supported by the FPGA FIFO. Currently, a value of “001” is defined, which describes a FIFO depth of 2048 samples.

DAQ4-0 Indicates the number of D/A channels available on the board.

Digital I/O Feature ID: Base+26 (Read)

Bit:	7	6	5	4	3	2	1	0
Name:	DIOQ7-0							

DIOQ7-0 Indicates the number of DIO pins available on the board.

PWM and Ctr/Timer Feature ID: Base+27 (Read)

Bit:	7	6	5	4	3	2	1	0
Name:	PWMQ3-0				CTRQ3-0			

PWMQ3-0 Indicates the number of PWM channels available on the board.

CTRQ3-0 Indicates the number of counter/timers available on the board.

Chip ID LSB: Base+28 (Read)

Bit:	7	6	5	4	3	2	1	0
Name:	ID7-0							

ID7-0 (See Chip ID MSB: Base+29, below)

Chip ID MSB: Base+29 (Read)

Bit:	7	6	5	4	3	2	1	0
Name:	ID15	ID14-8						

ID15 Prototype/released board indicator:
 0 = Prototype/unreleased version.
 1 = Released design.

ID14-8 Together with Chip ID LSB: Base+28, indicates the unique chip ID according to a (TBD) format. Each revision of the chip contains a unique 16-bit ID to enable software to distinguish between different board versions. The current chip ID should be 0x8000 or higher.

Page Select and Reset Command: Base+0 (Write)

Bit:	7	6	5	4	3	2	1	0
Name:	HOLDOFF	RESET	-	-	-	-	PAGE	

HOLDOFF When this bit is set, the chip ignores any data written to this register. This bit enables shadowing this register with another device at the same address.

RESET Reset the entire data acquisition circuit. After a reset, the following conditions are true:

- Digital I/O ports are set to input mode and all output registers are cleared to 0.
- A/D channel registers and range settings are cleared to zero, except for the Analog Configuration Register (Base+1) which is set to 0x04.
- D/A channels are cleared to mid-scale or zero-scale, depending on the board jumper setting.
- Counter/timers are disabled and counter registers are cleared to zero.
- Watchdog timer is disabled and timer registers are cleared to zero.
- FIFO is reset, causing all contents to be lost, and threshold is set to 1024 samples.
- The internal channel / gain table is reset to all zeros.

PAGE Select page.
 0 = Main features page
 1 = Extended features page
 2 = ID page
 3 = Copyright notice page

Copyright Notice: Base+1 to Base+31 (Read)

Bit:	7	6	5	4	3	2	1	0
Name:	Copyright Notice Text							

Copyright Notice Text 31 bytes of 8-bit ASCII-formatted copyright notice text.

Data Acquisition Circuit Configuration

There are three primary configuration options for the data acquisition circuitry on the Hercules II EBX board.

- Single-ended versus differential (A/D)
- Unipolar or bipolar (A/D)
- Unipolar or bipolar (D/A)

These settings are configured in software, using the PAGE 0 register, Analog Configuration: Base+1. No jumper configuration is needed.

Single-ended/Differential Inputs

Hercules II EBX accepts both single-ended and differential inputs. A single-ended input uses 2 wires: input and ground. The measured input voltage is the difference between the two wires. A differential input uses 3 wires: input (+), input (-), and ground. The measured input voltage is the difference between the (+) and (-) inputs.

Differential inputs are frequently used when the grounds of the input device and the measurement device (Hercules II EBX) are at different voltages, or when a low-level signal is measured that has its own ground wire. A differential input also has higher noise immunity than a single-ended input, since most noise affects both (+) and (-) input wires equally, cancelling out in the noise in the measurement. The disadvantage of differential inputs is that only half as many are available, since two input pins are required to produce a single differential input. Hercules II EBX can be configured for either 32 single-ended inputs or 16 differential inputs.

If you have a combination of single-ended and differential input signals, select differential mode. Then, to measure the single-ended signals, connect the signal to the (+) input and connect analog ground to the (-) input.

The maximum measurable rail voltage is +/- 10V for differential inputs. Any voltage outside of this range is measured as at the maximum rail. As an example, if VIN0+ = +15V and VIN0- = +10V the differential voltage is measured as 0V, since both voltages are outside of the maximum measurable range).

WARNING: The maximum range of voltages that can be applied to an analog input on Hercules II EBX without damage is $\pm 35V$. If you connect the analog inputs to a circuit whose ground potential plus maximum signal voltage exceeds $\pm 35V$, the analog input circuit may be damaged. Check the ground difference between the input source and the Hercules II EBX board before connecting analog input signals.

Unipolar/Bipolar Inputs

The analog inputs can be configured for unipolar (positive input voltages only) or bipolar (both negative and positive input voltages).

Analog Output Configuration

The four analog outputs can also be configured for unipolar (positive voltages only) or bipolar (both negative and positive output voltages). In unipolar mode, the outputs range between 0-10V. In bipolar mode, the outputs range between $\pm 10V$.

When the board powers up or is reset, the analog outputs are also reset. The D/A powers up in unipolar mode with zero-scale output (0V default).

Analog-to-Digital Input Ranges and Resolution

Overview

Hercules II EBX uses a 16-bit A/D converter. The full range of numerical values for a 16-bit number is 0 - 65535. However, the A/D converter uses twos-complement notation so the A/D value is interpreted as a signed integer ranging from -32768 to +32767.

The smallest change in input voltage that can be detected is $1/(2^{16})$, or $1/65536$, of the full-scale input range. This smallest change results in an increase or decrease of one in the A/D code, and is referred to as one Least Significant Bit (1 LSB).

The analog inputs on Hercules II EBX have three configuration options.

- Single-ended or differential mode
- Unipolar or bipolar mode
- Input range (gain)

The single-ended/differential configuration, unipolar/bipolar configuration and the input range selection are all handled in software.

Input Range Selection

Hercules II EBX can be configured to measure both unipolar (positive only) and bipolar (positive and negative) analog voltages. This configuration is done using the Page 0 register, Analog Configuration: Base+1, and applies to all inputs. In addition, you can select a gain setting for the inputs, which causes them to be amplified before they reach the A/D converter. The gain setting is controlled in software, so it can be changed on a channel-by-channel basis. In general, you should select the highest gain (smallest input range) that will allow the A/D converter to read the full range of voltages over which your input signals will vary. If you pick too high of a gain, then the A/D converter clips at either the high end or low end, and you will not be able to read the full range of voltages on your input signals.

Input Range Table

The table below indicates the analog input range for each possible configuration. The polarity is set in the Page 0 register, Analog Configuration: Base+1, and the gain is set with the G1 and G0 bits in the Page 0 register, Input Range Control: Base+4. The Gain value in the table is provided for clarity. The single-ended vs. differential setting has no impact on the input range or the resolution.

<i>Polarity</i>	<i>G1</i>	<i>G0</i>	<i>Input Range</i>	<i>Resolution (1 LSB)</i>
Bipolar	0	0	± 10V	305µV
Bipolar	0	1	± 5V	153µV
Bipolar	1	0	± 2.5V	76µV
Bipolar	1	1	± 1.25V	38µV
Unipolar	0	0	0-10V	153µV
Unipolar	0	1	0-5V	76µV
Unipolar	1	0	0-2.5V	38µV
Unipolar	1	1	0-1.25V	19µV

Performing an A/D Conversion

This chapter describes the steps involved in performing an A/D conversion on a selected input channel using direct programming (without the driver software). Performing an A/D conversion according to the following steps. Each step is discussed in detail, below.

1. Select the input channel.
2. Select the input range.
3. Wait for analog input circuit to settle.
4. Initiate an A/D conversion.
5. Wait for the conversion to finish.
6. Read the data from the board.
7. Convert the numerical data to a meaningful value.

Select the Input Channel

To select the input channel to read, write a low-channel/high-channel pair to the Page 0 register pair, A/D Low Channel: Base+2 and A/D High Channel : Base+3. For the Hercules II EBX, only 5 bits are supported for each setting, for 32 potential input source channels. When you write any value to these registers, the current A/D channel is set to the low channel.

For example, to set the board to channel 4 only, write 0x04 to Base+2 (low channel) and 0x04 to Base+3 (high channel). To set the board to read channels 0 through 15, write 0x00 to Base+2 (low channel) and 0x0F to Base+3 (high channel).

When you perform an A/D conversion, the current channel is automatically incremented to the next channel in the selected range. Therefore, to perform A/D conversions on a group of consecutively-numbered channels, you do not need to write the input channel prior to each conversion. For example, to read from channels 0 - 2, write 0x00 to base+2 and 0x02 to base+3. The first conversion is on channel 0, the second is on channel 1 and the third is on channel 2. The channel counter then wraps around to the beginning so the fourth conversion is on channel 0, and so on.

If you are sampling the same channel repeatedly, set both high and low to the same value as in the first example, above. On subsequent conversions you do not need to set the channel again.

Select the Input Range

Select the input range from among the available ranges. If the range is the same as for the previous A/D conversion it does not need to be set again. Write this value to the Page 0 register, A/D Input Range Control: Base+4.

For example, for a global (affects all channels) $\pm 5V$ range (gain of 2), write 0x01 to Base+4.

Wait for Analog Input Circuit to Settle

After writing to either the channel registers (Base+2, Base+3) or the input range register (Base+4), you must allow time for the analog input circuit to settle before starting an A/D conversion. The board has a built-in 10 μ S timer to assist with the wait period. Monitor the WAIT bit at register Base+4, bit 6. When the bit is 1, the circuit is actively settling on the input signal. When the bit is 0, the board is ready to perform A/D conversions.

Perform an A/D Conversion on the Current Channel

After the previous steps are completed, start the A/D conversion by writing to Base+15, bit 0.

```
outp(base +15,0x01);
```

This write operation only triggers the A/D if AINTE = 0 (interrupts are disabled). When AINTE = 1, the A/D can only be triggered by the on-board counter/timer or an external signal. This protects against accidental triggering by software during a long-running interrupt-based acquisition process.

Wait for the Conversion to Finish

The A/D converter chip takes up to either 4 or 9 microseconds to complete one A/D conversion, depending on the scan interval setting (Base + 12 : bit 3). Most processors and software can operate fast enough so that if you try to read the A/D converter immediately after starting the conversion, you will beat the A/D converter and get invalid data. Therefore the A/D converter provides a status signal, “ADBUSY,” to indicate whether it is busy or idle. This bit can be read back as bit 7 in the “A/D Range/Status Readback Register“ at Page 0 : Base+4. When the A/D converter is busy (performing an A/D conversion), this bit is 1 and the program must wait. When the A/D converter is idle (conversion is done and data is available), this bit is 0 and the program may read the data. Here are examples:

```
while (inp(base+4) & 0x80); // Wait for conversion to finish before proceeding
```

This method could hang your program if there is a hardware fault and the bit is stuck at 1. Better is to use a loop with a timeout:

```
int checkstatus() // returns 0 if ok, -1 if error
int i;
for (i = 0; i < 10000; i++)
{
    if !(inp(base+4) & 0x80) then return(0); // conversion completed
}
return(-1); // conversion did not complete
```

Read the Data from the Board

Once the conversion is complete, you can read the data back from the A/D converter. The data is a 16-bit value and can be read back as either two 8-bit bytes or one 16-bit word. For 8-bit accesses, the LSB must be read from the board before the MSB, because the data is inserted into the board’s FIFO in that order. Unlike other registers on the board, the A/D data may only be read one time, since each time a byte is read from the FIFO, the FIFO internal pointer advances and the byte is no longer available.

Note: Reading data from an empty FIFO returns unpredictable results.

The following pseudo-code illustrates how to read and construct the 16-bit A/D value with 8-bit accesses:

```
LSB = inp(base);
MSB = inp(base+1);
Data = MSB * 256 + LSB; // combine the 2 bytes into a 16-bit value
```

Alternatively, the value can be read as one 16-bit value, which is preferred since this method increases overall system bandwidth while reading data from the FIFO. For example,

```
Data = inpw(base); // Where the MSB and LSB are read in one access
```

The final data is interpreted as a 16-bit signed integer in the range -32768 to +32767. The A/D LSB register and A/D MSB register can be combined in one 16-bit read. These two registers fully support 16-bit I/O reads in hardware so the most efficient I/O method is to read the two bytes as a single 16-bit word.

Note: The data range always includes both positive and negative values, even if the board is set to a unipolar input range. The data must now be converted to volts or other engineering units by using a conversion formula, as shown below.

In scan mode, the behavior is the same except that when the program initiates a conversion. All channels in the programmed channel range are sampled once and the data are stored in the FIFO. The FIFO depth register increments by the scan size. When ADBUSY goes low, the program should read the data for all channels.

Convert the numerical data to a meaningful value

Once the A/D value is read, it needs to be converted to a meaningful value. The first step is to convert it back to the actual measured voltage. Afterwards, you may need to convert the voltage to some other engineering units. For example, the voltage may come from a temperature sensor and the voltage would then need to be converted to the corresponding temperature, according to the temperature sensor's characteristics.

Since there are a large number of possible input devices, this secondary step is not included here. Only conversion to input voltage is described. However, you can combine both transformations into a single formula if desired.

To convert the A/D value to the corresponding input voltage, use the following formulas.

Conversion Formula for Bipolar Input Ranges

$$\text{Input voltage} = \text{A/D value} / 32768 * \text{Full-scale input range}$$

Example:

Given, Input range is $\pm 5\text{V}$ and A/D value is 17761.

Therefore,

$$\text{Input voltage} = 17761 / 32768 * 5\text{V} = 2.710\text{V}.$$

For a bipolar input range,

$$1 \text{ LSB} = 1/32768 * \text{Full-scale voltage}.$$

The table, below, shows the relationship between A/D code and input voltage for a bipolar input range (V_{FS} = Full scale input voltage).

<i>A/D Code</i>	<i>Input Voltage Symbolic Formula</i>	<i>Input Voltage for $\pm 5\text{V}$ Range</i>
-32768	$-V_{FS}$	-5.0000V
-32767	$-V_{FS} + 1 \text{ LSB}$	-4.9998V
...
-1	-1 LSB	-0.00015V
0	0	0.0000V
1	+1 LSB	0.00015V
...
32767	$V_{FS} - 1 \text{ LSB}$	4.9998V

Conversion Formula for Unipolar Input Ranges

$$\text{Input voltage} = (\text{A/D value} + 32768) / 65536 * \text{Full-scale input range}$$

Example:

Given, Input range is 0-5V and A/D value is 17761.

Therefore,

$$\text{Input voltage} = (17761 + 32768) / 65536 * 5\text{V} = 3.855\text{V}.$$

For a unipolar input range, 1 LSB = $1/65536 * \text{Full-scale voltage}$.

The following table illustrates the relationship between A/D code and input voltage for a unipolar input range (V_{FS} = Full scale input voltage).

<i>A/D Code</i>	<i>Input Voltage Symbolic Formula</i>	<i>Input Voltage for 0–5V Range</i>
-32768	0V	0.0000V
-32767	1 LSB ($V_{FS} / 65536$)	0.000076V
...
-1	$V_{FS} / 2 - 1 \text{ LSB}$	2.4999V
0	$V_{FS} / 2$	2.5000V
1	$V_{FS} / 2 + 1 \text{ LSB}$	2.5001V
...
32767	$V_{FS} - 1 \text{ LSB}$	4.9999V

A/D Scan, Interrupt, and FIFO Operation

The control bits SCANEN (scan enable) and AINTE (A/D interrupt enable), in conjunction with the FIFO, determine the behavior of the board during A/D conversions and interrupts.

At the end of an A/D conversion, the 16-bit A/D data is latched into the 8-bit FIFO in an interleaved fashion; first the LSB, followed by the MSB. A/D data are read out of the FIFO with one 16-bit or two 8-bit read operations; first Base+0 (LSB), followed by Base+1 (MSB).

When SCANEN = 1, each time an A/D trigger occurs, the board performs an A/D conversion on all channels in the channel range programmed in the A/D Low Channel register (Base+2) and A/D High Channel register (Base+3). When SCANEN = 0, each time an A/D trigger occurs, the board performs a single A/D conversion and advances to the next channel to wait for the next trigger.

During interrupt operation (AINTE = 1), the FIFO fills with data until it reaches the threshold programmed in the FIFO threshold register, when an interrupt request occurs. If AINTE = 0, the FIFO threshold is ignored and the FIFO continues to fill.

The FIFO Threshold Registers should be set to the desired depth before configuring the system to begin operation in interrupt mode. The maximum FIFO depth can be read from the Page 2 register, FIFO Depth ID: Base+25. This register should always return a value of "001" for the FIFO ID, which means a maximum depth of 2048 samples.

To set the FIFO depth, the FIFO Threshold should be configured by writing the depth, in samples, to the Page 0 registers, FIFO Threshold LSB: Base+8 and FIFO Threshold MSB: Base+9. This setting is in units of *samples*, where one *sample* is two bytes. The current maximum setting is 2047 (Base+8 = 0xFF and Base+9 = 0x07).

If the FIFO reaches its limit, as set in the two Page 0 registers, FIFO Threshold: Base+8 and Base+9), the next time an A/D conversion occurs the FIFO Threshold flag: Base+14, bit 3, is set. At the same time, an interrupt is generated, provided FIFOEN = 1 and ADINTE = 1.

If the FIFO overflows, the Overflow flag OVF is set as the 2049th sample is taken. In this case, the FIFO does not accept additional data, and its contents are preserved and may be read. To clear the overflow condition, the program must reset the FIFO by writing to the FIFORST bit in register Base+15, or a hardware reset must occur.

The current FIFO state can be read at any time by checking the two Page 0 FIFO depth registers, FIFO Depth LSB: Base+10 and FIFO Depth MSB: Base+11. These registers return the number of samples currently in the FIFO, and are incremented with each stored A/D converter sample and decremented with every FIFO sample read; using the A/D LSB and A/D MSB registers located at Base+0 and Base+1, respectively.

In Scan mode (SCANEN = 1), the FIFO threshold should be set to a number at least equal to the scan size and in all cases equal to an integral number of scans. For example, if the scan size is 8 channels, the FIFO threshold could be set to 8, 16, 24, 32, 40, 48, etc. but not less than 8. In this way, the interrupt occurs at the end of the scan and the interrupt routine can read a complete scan or set of scans each time it runs.

In non-scan mode (SCANEN = 0), the FIFO threshold should be set to a level that minimizes the interrupt rate but leaves enough time for the interrupt routine to respond before the next A/D conversion occurs. Remember that no data are available until the interrupt occurs. If the rate is slow the delay to receive A/D data may be long. Therefore, for slow sample rates, the FIFO threshold should be small. If the sample rate is high, the FIFO threshold should be high to reduce the interrupt rate. However, remember that the remaining space in the FIFO determines the time the interrupt routine has to respond to the interrupt request. If the FIFO threshold is too high, the FIFO may overflow before the interrupt routine responds. A good rule of thumb is to limit the interrupt rate to no more than 1,000-2,000 per second in Windows and Linux or 10,000 per second in DOS. Experimentation may be needed to determine the optimum FIFO threshold for each application.

The table on the next page describes the board's behavior for each of the four possible combinations of AINTE and SCANEN values. The interrupt software behavior describes the operation of the Diamond Systems Corporation Universal Driver software. If you write your own software or interrupt routine, you should conform to the described behavior for optimum results.

Hercules II A/D Operating Modes

This section references the control bits and values listed in the table, below.

<i>Bit Name</i>	<i>Bit Register Location</i>
LOW	Page 0, Base+2, 5-bit number 0-31
HIGH	Page 0, Base+3, 5-bit number 0-31
WAIT	Page 0, Base+4, bit 6
ADBUSY	Page 0, Base+4, bit 7
FIFO threshold	Page 0, Base+8 (LSB) and Base+9 (MSB)
CLKEN	Page 0, Base+13, bit 0
CLKSEL	Page 0, Base+13, bit 1
SCANEN	Page 0, Base+13, bit 2
AINTE	Page 0, Base+13, bit 4
ADSTS	Signal from A/D converter (called BUSY at A/D output)

There are eight operating modes to consider for A/D conversions using FIFOEN, SCANEN, and AINTE. In all modes, at the end of an AD conversion A/D data is latched into the FIFO. Data are read from the FIFO with two read operations, nominally, from Base+0 and Base+1. However, reading from either address results in the same byte being read from the FIFO so the program can actually perform two reads from the same address to get the A/D data. For all modes where AINTE = 1, CLKEN must also be set to 1.

The following table shows the A/D operating modes.

<i>AINTE</i>	<i>FIFOEN</i>	<i>SCANEN</i>	<i>Operation</i>
0	0	0	Single A/D conversions are triggered by write to Base+15, bit 0. ADBUSY = ADSTS (from A/D) No interrupt occurs. The user program monitors ADDBUSY and reads A/D data when it goes low.
0	0	1	A/D Scans are triggered by write to Base+15, bit 0. All channels between LOW and HIGH are sampled. ADBUSY goes high at the first ADSTS high pulse and stays high until the last ADSTS pulse goes low. No interrupt occurs. The user program monitors WAIT and reads the A/D data when it goes low.
0	1	0	Same operation as case 000 above. The FIFO is not used in this case.
0	1	1	Same operation as case 001 above. The FIFO is not used in this case.
1	0	0	Single A/D conversions are triggered by the source selected with CLKSEL. ADBUSY = ADSTS INT goes high after each conversion is done, when ADDBUSY goes low. The interrupt routine reads one A/D sample each time it runs.
1	0	1	A/D Scans are triggered by the source selected with CLKSEL. ADBUSY goes high at the first ADSTS high pulse and stays high until the last ADSTS pulse goes low. INT goes high after the last ADDBUSY pulse goes low, when WAIT goes low. The interrupt routine reads out one entire A/D scan each time it runs.
1	1	0	Single A/D conversions are triggered by the source selected with CLKSEL. ADBUSY = ADSTS A/D interrupt occurs when the FIFO reaches its programmed threshold. The interrupt routine reads out a number of samples equal to the FIFO threshold each time it runs.
1	1	1	A/D scans are triggered by the source selected with CLKSEL. ADBUSY goes high at the first ADSTS high pulse and stays high until the last ADSTS pulse goes low. INT goes high after the last ADDBUSY pulse goes low, when WAIT goes low AND an integral no. of scans has occurred AND the FIFO threshold is reached. The interrupt routine reads out a number of samples equal to the FIFO threshold each time it runs.

Digital-to-Analog Output Ranges and Resolution

Description

Hercules II EBX uses a 4-channel 12-bit D/A converter (DAC) to provide four analog outputs. A 12-bit DAC can generate output voltages with the precision of a 12-bit binary number. The maximum value of a 12-bit binary number is $2^{12} - 1$, or 4095, so the full range of numerical values that the DACs support is 0 - 4095. The value 0 always corresponds to the lowest voltage in the output range, and the value 4095 always corresponds to the highest voltage minus 1 LSB. The theoretical top end of the range corresponds to an output code of 4096 which is impossible to achieve.

Note: In this manual, the terms analog output, D/A, and DAC are all used interchangeably to mean the conversion of digital data originating from the Hercules II-EBX computer hardware to an analog signal terminating at an external source.

Resolution

The resolution is the smallest possible change in output voltage. For a 12-bit DAC the resolution is $1/(2^{12})$, or $1/4096$, of the full-scale output range. This smallest change results from an increase or decrease of 1 in the D/A code, so this change is referred to as 1 least significant bit (1 LSB). The value of this LSB is calculated as follows.

$$1 \text{ LSB} = \text{Output voltage range} / 4096$$

Example:

For, Output range = 0-10V,

$$\text{Output voltage range} = 10\text{V} - 0\text{V} = 10\text{V}$$

Therefore,

$$1 \text{ LSB} = 10\text{V} / 4096 = 2.44\text{mV}$$

Example:

For, Output range = $\pm 10\text{V}$;

$$\text{Output voltage range} = 10\text{V} - (-10\text{V}) = 20\text{V}$$

Therefore,

$$1 \text{ LSB} = 20\text{V} / 4096 = 4.88\text{mV}$$

Output Range Selection

The Page 0 register, Analog Configuration: Base+1 is used to select the DAC output range. The DACs can be configured for 0-10V or $\pm 10\text{V}$.

D/A Conversion Formulas and Tables

The formulas below explain how to convert between D/A codes and output voltages.

D/A Conversion Formulas for Unipolar Output Ranges

$$\text{Output voltage} = (\text{D/A code} / 4096) * \text{Reference voltage}$$

$$\text{D/A code} = (\text{Output voltage} / \text{Reference voltage}) * 4096$$

Example:

For,

$$\text{Output range in unipolar mode} = 0 - 10\text{V},$$

and,

$$\text{Full-scale range} = 10\text{V} - 0\text{V} = 10\text{V},$$

if,

$$\text{Desired output voltage} = 2.000\text{V},$$

$$\text{D/A code} = 2.000\text{V} / 10\text{V} * 4096 = 819.2 \Rightarrow 819$$

Note: the output code is always an integer.

For the unipolar output range 0-10V, 1 LSB = $1/4096 * 10\text{V} = 2.44\text{mV}$.

The following table illustrates the relationship between D/A code and output voltage for a unipolar output range (V_{REF} = Reference voltage).

<i>D/A Code</i>	<i>Output Voltage Symbolic Formula</i>	<i>Output Voltage for 0-10V Range</i>
0	0V	0.0000V
1	1 LSB (V _{REF} / 4096)	0.0024V
...
2047	V _{REF} / 2 - 1 LSB	4.9976V
2048	V _{REF} / 2	5.0000V
2049	V _{REF} / 2 + 1 LSB	5.0024V
...
4095	V _{REF} - 1 LSB	9.9976V

D/A Conversion Formulas for Bipolar Output Ranges

$$\text{Output voltage} = ((\text{D/A code} - 2048) / 2048) * \text{Output reference}$$

$$\text{D/A code} = (\text{Output voltage} / \text{Output reference}) * 2048 + 2048$$

Example:

For,

$$\text{Output range in bipolar mode} = \pm 10\text{V}$$

and,

$$\text{Full-scale range} = 10\text{V} - (-10\text{V}) = 20\text{V}$$

if,

$$\text{Desired output voltage} = 2.000\text{V}$$

$$\text{D/A code} = 2\text{V} / 10\text{V} * 2048 + 2048 = 2457.6 \Rightarrow 2458$$

For the bipolar output range $\pm 10\text{V}$, 1 LSB = $1/4096 * 20\text{V}$, or 4.88mV. The following table illustrates the relationship between D/A code and output voltage for a bipolar output range (V_{REF} = Reference voltage).

<i>D/A Code</i>	<i>Output Voltage Symbolic Formula</i>	<i>Output Voltage for $\pm 10\text{V}$ Range</i>
0	$-V_{\text{REF}}$	-10.0000V
1	$V_{\text{REF}} + 1 \text{ LSB}$	-9.9951V
...
2047	-1 LSB	-0.0049V
2048	0	0.0000V
2049	+1 LSB	0.0049V
...
4095	$V_{\text{REF}} - 1 \text{ LSB}$	9.9951V

Generating an Analog Output

There are three steps involved in performing a D/A conversion, or generating an analog output. Each step is described in more detail, below. The descriptions use direct programming instead of driver software.

1. Compute the D/A code for the desired output voltage.
2. Write the value to the selected output channel.
3. Wait for the D/A to update.

Compute the D/A Code for the Desired Output Voltage

Use the formulas on the preceding pages to compute the D/A code required to generate the desired voltage.

Note: The DAC cannot generate the actual full-scale reference voltage; to do so would require an output code of 4096, which is not possible with a 12-bit number. The maximum output value is 4095. Therefore, the maximum possible output voltage is always 1 LSB less than the full-scale reference voltage.

Write the Value to the Selected Output Channel Registers

Use the following formulas to compute the LSB and MSB values.

$$\text{LSB} = \text{D/A Code} \& 255 \text{ ;keep only the low 8 bits}$$

$$\text{MSB} = \text{int}(\text{D/A code} / 256) \text{ ;strip off low 8 bits, keep 4 high bits}$$

Example:

For,

Output code = 1776

Compute,

LSB = 1776 & 255 = 240 (0xF0)

and

MSB = int(1776 / 256) = int(6.9375) = 6

The LSB is an 8-bit number in the range 0-255. The MSB is a 4-bit number in the range 0-15.

The MSB is always rounded *down*. The truncated portion is accounted for by the LSB.

Write the computed values to the output registers. The LSB is written to Page 0 register Base+6. The MSB is written to Page 0 register Base+7.

```
outp(Base + 6, LSB);  
outp(Base + 7, MSB);
```

Set Registers for Channel

After the value for the given channel is set, make the channel selection to latch the data to the D/A. Decide whether or not to pass the data to the D/A immediately, *transparent pass-through mode*, or to latch and hold the data until all of the D/A channels are set, *simultaneous update mode*.

Transparent pass-through mode sends the data, written in the previous step, to the D/A beginning immediately after the channel selection is made. The D/A output is updated as soon as the data is transferred with a worst-case settling time of ~10µsec, as described in the DAC7715 specification.

Simultaneous update mode latches the data into an internal buffer for that channel, but will not update the A/D until instructed to do so. In this way, several, or all four, of the A/D channels can be configured and updated, simultaneously. This allows for a uniform transition time for all A/D outputs.

To send the data to the D/A immediately, write the channel number to Page 0 register Base+5, bits 1-0. For *transparent pass-through mode*, bit 8 should be reset to zero, as shown,

```
outp(Base + 5, ChannelNumber);
```

where *ChannelNumber* is 0-3.

To latch the data in preparation for more updates, not sending the data to the D/A until channel data updates are completed, write the channel number to Page 0 register Base+5, bits 1-0, also setting bit 8 to 1, as shown,

```
outp(Base + 5, 0x80 + ChannelNumber);
```

where *ChannelNumber* is 0-3.

The D/A data is held until a zero is written to the *simultaneous update* bit, at which time all of the latched data is updated at the same time. If data was previously latched with the *simultaneous update* bit set to one and the data for the last channel involved in the *simultaneous update* was written to Base+6 and Base+7, the final channel selection operates the same as a transparent mode write,

```
outp(Base + 5, ChannelNumber);
```

where *ChannelNumber* is 0-3.

This code sends all of the latched data to the D/A. The latched data is now enabled through the D/A and the analog outputs begin the transition to the selected values.

Wait for the D/A to Update

Writing the channel number to Base+5, regardless of the state of the *simultaneous update* bit, starts the D/A update process for the selected channel(s). The update process requires approximately 30 microseconds to transmit the data to the D/A chip and update the D/A circuit in the chip, if the data is to be passed through immediately. During this period, no attempt should be made to write to any other channel in the D/A using addresses Base+6 or Base+7.

The Page 0 register status bit ,DABUSY: Base+4, bit 5, indicates if the D/A is busy updating (1) or idle (0). After writing to the D/A, monitor the DABUSY bit until it is zero before continuing to the next D/A operation.

The time required to transfer data for a channel occurs whether or not the *simultaneous update* bit is set. The data is transferred, and the DABUSY signal is active, regardless of whether or not the data is immediately updated or is latched in preparation for later *simultaneous update*. The only difference in the two modes occurs after the digital data is transferred. In *transparent mode* the data immediately passes through the D/A, whereas *simultaneous update* mode concludes with the D/A output data unchanged.

Analog Circuit Calibration Resources

For a board with the Data Acquisition option, the Hercules II EBX data acquisition circuitry incorporates some advanced calibration features to allow the system to calibrate both the A/D and D/A signal conversion pathways. The registers involved in controlling these calibration features are listed in the following table.

<i>Register Bit Name</i>	<i>Register Location</i>	<i>Signal Name</i>	<i>Description</i>
ADBU	(all pages) Base+1, bit 0	ADCUNI(OUT)	A one sets A/D section to unipolar input mode.
DABU	(all pages) Base+1, bit 2	DACUNI(OUT)	A one sets D/A section to bipolar output mode.
CMUXEN	Page 0: Base+30, bit4	MUXEN4(OUT)	A one enables calibration voltages multiplexer.
SEDIFF	(all pages) Base+1, bit 1	ADDIFF(OUT)	A one sets A/D section to differential mode.
TrimDAC data	Page 1: Base+28, 8-bit	TrimDAC data, D7-D0	Data sent to TrimDAC.
TrimDAC address	Page 1: Base+29, bits 2-0	TrimDAC address, A2-A0	Address for TrimDAC.
TDACEN	Page 1: Base+30, bit 3	TDACEN	TrimDAC enabled when 1. Mutually exclusive with EE_EN control.

When Register bit CMUXEN=1, the board is in auto calibration mode. When this mode is enabled, specific calibration voltages are fed back to analog channel inputs. There are five calibration settings that can be used, described in the table below. These feedback voltages are selected based on the ADCH0 and ADCH1 settings. ADCH4-2 are ignored during auto-calibration.

<i>CMUXEN</i>	<i>SEDIFF</i>	<i>ADCH(I/O)</i>	<i>VCAL</i>	<i>Voltage</i>
0	-	-	-	-
1	0	0(0/0)	0	0
1	0	1(0/1)	1	2.5mV
1	0	2(1/0)	2	1.12V
1	0	3(1/1)	3	4.78V
1	0	X	4	VOUT0

Notes:

1. **VCAL0 is for bipolar A/D offset adjustments.**
2. **VCAL1 is for unipolar offset adjustments.**
3. **VCAL2 is for full scale 0-1.25, 0-2.5, +/-1.25 and +/-2.5 modes.**
4. **VCAL3 is for full scale 0-5, 0-10, +/-5 and +/-10 modes .**
5. **VCAL4 is D/A VOUT0 for D/A calibration; this loops Analog output “VOUT0” back.**

The following table shows the TrimDAC, AD8801, outputs.

<i>OUTPUT (TrimDAC address)</i>	<i>NAME</i>	<i>FUNCTION</i>	<i>POLARITY</i>
00	ADCOFF (coarse)	A/D offset, all modes, coarse	The same for bipolar, Inversed for unipolar
01	ADCOFF (fine)	A/D offset, fine	The same for bipolar, Inversed for unipolar
02	ADCFUL (coarse)	A/D full scale, all modes, coarse	Inversed
03	ADCFUL (fine)	A/D full scale, fine	Inversed
04	DACOFF (coarse)	D/A offset, coarse	Inversed
05	DACOFF (fine)	D/A offset, fine	Inversed
06	DACFUL (coarse)	D/A full scale, coarse	The same
07	DACFUL (fine)	D/A full scale, fine	The same

Notes:

1. **“The same” means: increase in the trimDAC value increases readout and vice versa**
2. **“Inversed” means: increase in the trimDAC value decreases readout and vice versa**
3. **“Coarse” adjustment is the basic trimDAC variance, while “Fine” only affects adjustment of about 1% of full effect in all modes**

Analog Circuit Calibration Procedures

Calibration applies only to boards with the analog I/O circuitry.

The analog I/O circuit is calibrated during production test prior to shipment. Over time the circuit may drift slightly. If calibration is desired, internal auto-calibration can be performed using the software routines provided with the Diamond Systems Corporation driver libraries, which are included with the Hercules II EBX development kit.

Six adjustments are possible:

- A/D bipolar offset.
- A/D unipolar offset.
- A/D full-scale.
- D/A bipolar offset.
- D/A unipolar offset.
- D/A full-scale.

The specific algorithms required to perform auto-calibration can be involved, and are too detailed to be presented in this document. The detailed procedures are provided in the included drivers and additional auto-calibration information can be provided as needed.

The auto-calibration settings are stored in nonvolatile memory in the calibration EEPROM and are reloaded each time the on-board FPGA, or system, is reset.

Using EEPROM

An EEPROM is used to store all TrimDAC adjustment values. These values are loaded on reset or power-up, and it is critical that these values are correct to maintain accurate A/D measurements. These settings are configured to defaults during manufacturing test. Do not change these settings without a complete understanding the impact of the change.

The EEPROM provides 256 bytes of non-volatile storage. The first 128 bytes, addresses 0x00-0x7F, are reserved for auto-calibration settings and should not be overwritten. The last 128 bytes are available for user-accessible nonvolatile storage.

Access to EEPROM data can be handled through the DSCUD software utilities.

Note: Remember that bytes 0-127 are reserved for system use (TrimDAC autocal values). Altering those values adversely affects system calibration.

Reading Value from EEPROM

Example: Read one byte from EEPROM location 128.

```
outp(base+0, 0x01);    // set page to page 1
outp(base+15, 0xA5);   // unlock EEPROM
outp(base+29,0x80);    // set address location to 128 (0x80)
outp(base+30, 0xC0);   // Initiate transfer, set to read
while(inp(base+30) & 0x20); // Wait for EEPROM load to complete
data = inpb(base+28);  // data returned from EEPROM access
outp(base+0, 0x00);    // select page 0 (re-enables lock on EEPROM/TrimDAC)
```

Writing Value to EEPROM

Example. Write the byte value 0xAA to EEPROM location 254, then verify the data.

```
outp(base+0, 0x01);    // set page to page 1
outp(base+15, 0xA5);   // unlock EEPROM
outp(base+29,0xFE);    // set address location to 254 (0xFE)
outp(base+28, 0xAA);   // Set data to write to EEPROM
```

```

outp(base+30, 0x80);    // Initiate transfer, set to write
while (inp(base+30) & 0x20);    // Wait for EEPROM write to complete
outp(base+15, 0xA5);    // unlock EEPROM
outp(base +29,0xFE);    // set address location to 254 (0xFE)
outp(base+30, 0xC0);    // Initiate transfer, set to read
while (inp(base+30) & 0x20);    // Wait for EEPROM load to complete
Data = inpb(base+28);    // data returned from EEPROM access; data should be 0xAA
outp(base+0, 0x00);    // select page 0 (re-enables lock on EEPROM/TrimDAC)

```

Digital I/O Operation

Hercules II EBX contains 40 digital I/O lines organized as four 8-bit I/O ports: A, B, C, D and E. The direction for each port is independently programmable. The ports are accessed at registers Base+16 through Base+20, respectively, and the direction register is at Base+22. Port and direction registers are located at Page 0.

The digital I/O lines are located at pins 1 through 40 on connector J8. The lines are 3.3V and 5V logic compatible. Each output is capable of supplying -8mA in logic 1 state and +12mA in logic 0 state.

Register Base+22 bits DIRA, DIRB, DIRC, DIRD and DIRE control the direction of ports A, B, C, D and E, respectively. A zero indicates output and a one indicates input. All ports power up to input mode and the output registers are cleared to zero. When a port direction is changed to output mode, its output register is cleared to zero. When a port is in output mode, its value can be read.

There are two methods of programming the Digital I/O ports.

- As individual bits (useful for output only).
- As bytes (for either input or output).

Accessing a digital output port can be handled as bit- or byte-level accesses, interchangeably. The two methods are provided to allow maximum flexibility for output operations.

Bit-Mode Operation

To program a specific output bit, *bit-mode* operation can be used. This mode is selected by writing a one to the MODE bit of the register Base=22: Digital I/O Configuration/Bit Programming located. When setting bit mode, bits 6-4 select the DIO port (A-E, values 0-4), bits 3-1 select the bit within the port (bit selection 0-7), and bit 0 selects the value for the bit in question.

In *bit-mode*, an individual output bit for one of the 40 available DIO bits can be individually assigned a value. For example, the following code segment sets bit 4 of DIO port B to zero and sets DIO port B to an output, with all other ports set to input.

```

outp(base+22, 0x98);    // Selects: Bit Mode (bit 7=1),
                        //           Port B (bits 6-4 = 001),
                        //           bit 4 (bits 3-1 = 100),
                        //           value = 0 (bit 0=0)
outp(base+22, 0x02);    // Selects: DIO direction Mode (bit 7=0) and
                        //           Port B is output; Ports A,C,D,E are inputs

```

Byte-Mode Operation

For *byte-mode* operation, the data for a given byte is read or written to the appropriate DIO byte register. DIO ports A-E are located at Base+16 to Base+20, respectively. For example, the following code segment illustrates setting port A to output, with B-E as input, writing a value of 0xAA to port A, and reading data from port C.

```

outp(base+22, 0x01);    // Selects: DIO direction Mode (bit 7=0) and
                        //           Port A is output; Ports B,C,D,E are inputs

```

```

outp(base+16, 0xAA); // Send data to DIO output port A
data = inp(base+18); // Read data from port C

```

Special Digital I/O Operation – Port E

In addition to the standard Digital I/O operation detailed above, port E may alternatively be configured for some special I/O functions, allowing access to several special-purpose Digital I/O controls. These special functions are controlled with the DIOCTR0 and DIOCTR1 bits.

Bit DIOCTR0 controls the special functions for DIO E3-E0.

<i>J8 Pin Number</i>	<i>DIOCTR0</i>	
	<i>0</i>	<i>1</i>
33	DIO E0	PWM0
34	DIO E1	PWM1
35	DIO E2	PWM2
36	DIO E3	PWM3

See the section on PWM functionality for details on PWM functions for these pins, when DIOCTR0 = 1.

DIOCTR1 controls the special functions for DIO E7-E4.

<i>J8 Pin Number</i>	<i>DIOCTR1</i>	
	<i>0</i>	<i>1</i>
37	DIO E4	GATE0
38	DIO E5	DIOLATCH
39	DIO E6	TOUT1
40	DIO E7	GATE1

See the sections on counter/timer operation and DIO handshaking mode for details on these special functions, which are available only when DIOCTR1 is set to one.

DIO Handshaking Operation

Normally, the DIO data is transferred through the data registers with each read. If a handshaking method is desired, two signals are provided to allow this type of transfer.

- DIOLATCH
 - Input to system (low latches all input data; high passes data through directly).
 - Normally pulled-up (passes all DIO data through without handshaking); affected by DIO pull-ups.
 - Falling edge generates IRQ when DINTE: Base+13, bit 5 is set to one.
 - Present on DIO Header J8, pin 39.
 - NOTE : Only accessible when DIOCTR is set to one.
- ACK
 - Output from system; driven high when DIOLATCH transitions from high-to-low. ACK is driven low as soon as latched data is read into the system.
 - Present on DIO Header J8, pin 43.

The handshaking sequence looks similar to the illustration, below.

Figure 42: DIOLATCH/ACK Handshaking Sequence

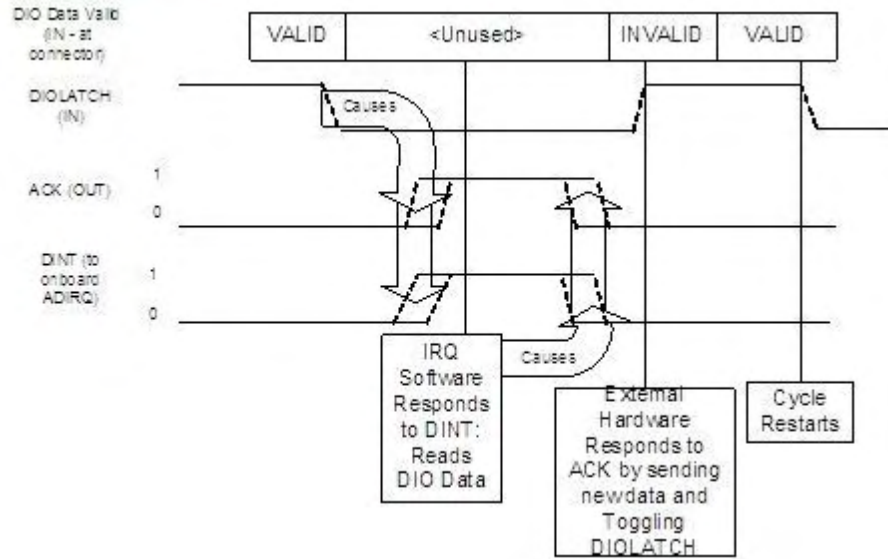

DIO Pull-up/Down Settings

All DIO signals have some basic ESD and over/under-voltage protection. In addition, all signals can be configured with pull-up or pull-down resistors to set a given I/O voltage when no input signal is provided. This pull-up/pull-down setting should always be made for the following two reasons.

1. To prevent floating inputs (latch-up from floating input where CMOS I/O pins are involved).
2. To set a known voltage level for inputs that are not driven.

This is particularly useful for signals such as DIOLATCH and EXTTRIG, for example, where a floating input could cause erratic or erroneous results when the latch/counter edge trigger occurs randomly.

To set DIO signal pull-ups or pull-downs, a jumper must be added across signals on connector J5, as shown in the table.

<i>DIO Signal (range)</i>	<i>Pull-up</i>	<i>Pull-down</i>	<i>Notes</i>
A7-0, B7-0, C7-0, D7-0, E3-0	1-3	3-5	PWM outputs are included.
E7-4 (GATE0, TOUT1, GATE1, DIOLATCH)	2-4	4-6	Affects DIO handshaking and GATE for both counters.

Notes:

1. “Pull-up” means that a weak (47kOhm) pull-up resistor will be connected between the DIO signal and +3.3V. This sets the DIO signal to a “1” value when there is no external source driving the signal.
2. “Pull-down” means that a weak (47kOhm) pull-down resistor will be connected between the DIO signal and ground. . This sets the DIO signal to a “0” value when there is no external source driving the signal.
3. **FPGA programming / updates:** These Pull-up/down resistors also affect signal outputs during the period when the FPGA is being loaded or re-loaded. During an FPGA update, the FPGA will briefly

tri-state all signals – during this period, the pull-up/down resistors will be the only current source coming from the board through the DIO signals.

As an example, to set all standard DIO signals to zero by default and to allow DIO handshaking to be configured such that the DIOLATCH signal is pulled high, for normal handshaking operation default follow these steps.

- Place a jumper across J5, pins 3-5, setting normal DIOs to zero when not driven.
- Place a jumper across J5, pins 2-4, setting DIO E7-E4 to one when not driven, including DIOLATCH, which is present on DIO E6 pin.

Counter/Timer Operation

Hercules II EBX contains two counter/timers that provide various timing functions on the board for A/D timing and user functions. These counters are controlled with registers in the on-board data acquisition controller FPGA.

Counter 0 – A/D Sample Control

The first counter, Counter 0, is a 24-bit divide-by-n counter used for controlling A/D sampling. The counter has an internal clock input, an external gate input (Gate 0, alternate function for DIO Channel E bit 4), and a dedicated output (TOUT 0). The input is a 10MHz or 100 kHz clock provided on the board and selected with bit CKFRQ0 in Page 0 Base+12, bit zero. The gate is an optional signal that can be input on pin 40 of the I/O header, J8, when Page 0 register DIOCTR1: Base+12, bit 5 is one. If this signal is not used, the counter runs freely. The TOUT 0 signal output is a positive pulse whose frequency is equal to the input clock divided by the 24-bit divisor programmed into the counter. The output is always present on pin 42 of the I/O header, J8.

The counter operates by counting down from the programmed divisor value. When it reaches zero, it outputs a positive-going pulse equal to one input clock period of 100ns or 10µs, depending on the input clock selected by CKFRQ0. It then reloads to the initial load value and repeats the process indefinitely.

The output frequency can range from 5MHz (10MHz clock, divisor = 2) down to 0.006Hz (100 kHz clock divided by 16,777,215, or $2^{24}-1$). The output is fed into the A/D timing circuit and can be selected to trigger A/D conversions when AINTE is one and CLKSEL is zero in Base+13, bit 1. Using the control Page 0 registers at Base+13 and Base+27, the counter can be loaded, cleared, enabled and disabled. The optional gate can be enabled and disabled, and the counter value can be latched for reading.

Counter 1 – Counting/Totalizing Functions

The second counter, Counter 1, is similar to Counter 0 except it is a 16-bit counter. It also has an internal clock input, as well as an external input (EXTTRIG), an external gate (GATE 1), and an output (TOUT1). The gate and output signals are present on the I/O header only when DIOCTR is zero. The input may come from either the external trigger signal or the on-board clock generator. When the on-board clock generator is used, the clock frequency is either 10MHz or 100 KHz as determined by Page 0 register control bit CKFRQ1 located at Base+12, bit 1.

The output (TOUT1) is a positive-going pulse that appears on pin 38 of I/O header J8 when DIOCTR1 is one. The output pulse occurs when the counter reaches zero. When the counter reaches zero it reloads and starts over on the next clock pulse. The output stays high the entire time the counter is at zero; i.e., the interval from the input pulse that causes the counter to reach zero until the input pulse that causes the counter to reload.

When CLKSRC1 is one (external source), Counter 1 counts positive edges of the signal on pin 41 (EXTTRIG) on the I/O header. The counter can either be free running or gated, as determined by the Page 0 register Gate Enable control bit, GTEN: Base +27, bit 4.

The gate signal is provided on pin 37 when DIOCTR1 is one, enabling counter functions on I/O header, and GTEN is one, enabling gating for this counter. If the gate signal is high then the counter counts, and if it is low the counter holds its value and ignore input pulses. This pin can have a pull-up so the counter can operate without any external gate signal.

When DIOCTR1 is zero, Counter 1 takes its input from the on-board clock generator based on the value of the Page 0 register bit, CKFRQ1, located at Base+12. There is no gating and the counter runs continuously.

Counter 1 may be used as either a pulse generator or a totalizer/counter. In pulse generator mode the output signal on pin 26 is of interest. In totalizer/counter mode the counter value is of interest and may be read by first latching the value and then reading it.

Command Sequences

Diamond Systems provides driver software to control the counter/timers on Hercules II EBX. The information in this section is intended as a guide for programmers writing their own code, instead of using the driver, and to give a better understanding of the counter/timer operation.

The Page 0 counter control register is shown for reference.

Bit:	7	6	5	4	3	2	1	0
Name:	CTR	LATCH	GTDIS	GTEN	CTDIS	CTEN	LOAD	CLEAR

To Make a Counter Run (Load and Enable a Counter)

1. Load the desired initial value into the counter.
2. If you want to use the gate function, enable the gate.
3. Enable the counter.

To Read a Counter

1. Latch the counter. The counter continues to operate.
2. Read the value from the data registers.

A counter may be enabled or disabled at any time. If disabled, the counter ignores incoming clock edges.

The gating may be enabled or disabled at any time. When gating is disabled, the counter counts all incoming edges. When gating is enabled, if the gate is high the counter counts all incoming edges, and if the gate is low the counter ignores incoming clock edges.

Loading and Enabling a Counter

For counter 0, three bytes are required to load a 24-bit value. For counter 1, two bytes are needed for a 16-bit value. The value is an unsigned integer.

1. Write the data to the counter.

Break the load value into 3 bytes: low, middle, and high, (Two bytes for Counter 1) and write the bytes to the data registers in any sequence.

Counter 0:

```
outp(base+24,low);
outp(base+25,middle);
outp(base+26,high);
```

Counter 1:

```
outp(base+24,low);
outp(base+25,high);
```

2. Load the counter.

Counter 0:

```
outp(base+27,0x02);
```

Counter 1:

```
outp(base+27,0x82);
```

3. Enable the gate if desired.

Counter 0:	Counter 1:
<code>outp (base+27, 0x10);</code>	<code>outp (base+27, 0x90);</code>

4. Enable the counter.

Counter 0:	Counter 1:
<code>outp (base+27, 0x04);</code>	<code>outp (base+27, 0x84);</code>

Reading a Counter

1. Latch the counter.

Counter 0:	Counter 1:
<code>outp (base+27, 0x40);</code>	<code>outp (base+27, 0xC0);</code>

2. Read the data.

The value is returned in 3 bytes, low, middle, and high (2 bytes for counter 1).

Counter 0:	Counter 1:
<code>low=inp (base+24);</code>	<code>low=inp (base+24);</code>
<code>middle=inp (base+25);</code>	<code>high=inp (base+25);</code>
<code>high=inp (base+25);</code>	

3. Assemble the bytes into the complete counter value.

Counter 0:	Counter 1:
<code>val = high * 2^16 + middle * 2^8 + low;</code>	<code>val = high * 2^8 + low;</code>

Enabling the Counter Gate

Counter 0:	Counter 1:
<code>outp (base+27, 0x10);</code>	<code>outp (base+27, 0x90);</code>

The counter runs only when the gate input is high.

Disabling the Counter Gate

Counter 0:	Counter 1:
<code>outp (base+27, 0x20);</code>	<code>outp (base+27, 0xA0);</code>

The counter runs continuously.

Clearing a Counter

Clearing a counter is done to restart an operation. Normally, you only clear a counter after you have stopped (disabled) and read the counter. If you clear a counter while it is still enabled, it continues to count incoming pulses, so its value may not remain at zero.

1. Stop (disable) the counter.

Counter 0:	Counter 1:
<code>outp(base+27,0x08);</code>	<code>outp(base+27,0x88);</code>

2. Read the data (optional). See Reading a Counter, above.

3. Clear the counter.

Counter 0:	Counter 1:
<code>outp(base+27,0x01);</code>	<code>outp(base+27,0x81);</code>

Pulse Width Modulation Operation

Hercules II EBX contains four PWM generators for automatic generation of a regular pulse with independently-configurable duty cycle and frequency. These output signals are present on DIO Header J8, pins 33-36 (PWM output channel 0-3) when DIOCTR0 is one.

Each PWM consists of two 24-bit down counters, CT0 and CT1. CT0 controls the frequency, and CT1 controls the duty cycle, or length, of the active pulse. Each counter is initially loaded with the desired data, and desired clock frequencies are selected for each counter. CLK1 and CLK0 select 10MHz (0) or 100 KHz (1) for the clock source for their respective counters.

Each counter contains a 24-bit load register. The load registers are accessed by writing to Page 1, base+24 and Base+26 followed by a load command (Base+27, bit 7 = 0 indicates a PWM command) and may be written to at any time. When ENAB is zero, each counter is loaded from the load register using the load command. When ENAB is one, each counter is loaded from its load register on the next clock after CT0 is zero.

When ENAB is one, both counters count down at the same time. While CT1 is running, the PWM output is equal to the polarity selected by POL, where a value of one means the output is high during the active period when CT1 is counting down, and a value of zero means the output is low during the active period. This causes the output pulse to occur at the start of the cycle.

After CT1 reaches zero, it stops counting and the output switches to the opposite inactive polarity on the next clock. CT0 runs continuously. When CT0 is zero on the next clock, both counters reload from their load registers and the cycle repeats.

CT0 and CT1 may be reloaded while the PWM is running. The reload data is held in a separate load register for each counter and is not loaded into the counter until CT0 is zero. This allows the current cycle to complete without distortion. This implies that a long PWM cycle duration for the current cycle may cause a considerable update delay before the new settings are seen on the PWM outputs. If the current PWM cycle period is several seconds in duration and the PWM data is updated near the beginning of a cycle, the output is not updated with the new settings until several seconds later.

The ENAB bit controls PWM operation. When ENAB is one, the PWM runs, and when ENAB is zero, the PWM circuit is disabled. In the disabled state the PWM retains its current state but does not count input clocks, and the output is set to the inactive state as determined by POL.

OUTEN controls the output signal. If OUTEN is one, the output is active. If OUTEN is zero, the output is equal to the inactive state determined by POL. When POL is zero, the inactive state is zero, and when POL is one the inactive state is one. The truth table is as follows.

<i>CT1 Output</i>	<i>POL</i>	<i>OUTEN</i>	<i>Output Pin</i>	<i>Comments</i>
0	0	0	1	Active low, active, disabled
0	0	1	0	Active low, active, enabled
0	1	0	0	Active high, inactive, disabled
0	1	1	0	Active high, inactive, enabled
1	0	0	1	Active low, inactive, disabled
1	0	1	1	Active low, inactive, enabled
1	1	0	0	Active high, active, disabled
1	1	1	1	Active high, active, enabled

Pulse-Width Modulation Example

The following is a programming example to output a 1KHz signal with a 25% high duty cycle on PWM output 2.

Note: For 1KHz output, either reference clock, 10MHz or 100KHz, is suitable. In this example, we use the 10MHz reference clock.

1. Determine the value for the output frequency counter (counter 0).

$$\text{Counter 0 Value} = \text{Reference Clock} / \text{Desired Rate}$$

$$\text{Counter 0 Value} = 10\text{MHz} / 1\text{Khz}$$

$$\text{Counter 0 Value} = 10000$$

2. Determine the value for the duty cycle counter (counter 1).

$$\text{Counter 1 Value} = \text{Timer 0 Value} * \text{Duty Cycle}$$

$$\text{Counter 1 value} = 10000 * 0.25$$

$$\text{Counter 1 value} = 2500$$

3. Program the two counters.

```
outp(base + 0, 1); //Set page 1 (for PWM functions)

c0 = Counter 0 Value = 10000
outp(base + 24, (c0 >> 0) & 0xFF); //Counter 0 bits 0-7
outp(base + 25, (c0 >> 8) & 0xFF); //Counter 0 bits 8-15
outp(base + 26, (c0 >> 16) & 0xFF); //Counter 0 bits 16-23
outp(base + 27, 0x20); //This loads the value into counter 0 for PWM circuit 2

c1 = Counter 1 Value = 2500
outp(base + 24, (c1 >> 0) & 0xFF); //Counter 1 bits 0-7
outp(base + 25, (c1 >> 8) & 0xFF); //Counter 1 bits 8-15
outp(base + 26, (c1 >> 16) & 0xFF); //Counter 1 bits 16-23
outp(base + 27, 0x21); //This loads the value into counter 1 for PWM circuit 2
```

4. Configure and enable PWM output 2. These are the desired configuration values for Base+27.

<i>Bit Value</i>	<i>Description</i>
BIT7 = 1	Indicates PWM configuration byte
PWM0-1 = 2	Program PWM output 2
CLK = 0	Use the 10MHz reference clock
POL = 1	Active state = high (PWM will be high for the 25% duty cycle)
OUTEN = 1	Enable PWM output
ENAB = 1	Enable PWM circuit

From the above settings we get a configuration byte value of 0xA7.

```
outp(base + 0, 1); //Set page 1 (for PWM functions)
outp(base + 27, 0xA7); //Configure and enable PWM output 2
```

5. To enable PWM outputs, replacing Digital I/O Port E, bit3-0, set DIOCTR0 to one, leaving the rest of the Configuration Register as-is.

```
Data = inp(base + 12); // Read current Configuration Register settings
Data = Data || 0x10;   // Set DIOCTR0 = 1, forcing PWM3-0 onto DIO
outp(base + 12, Data); // Write settings back to Configuration Register
```

A 1KHz signal with a 25% high duty cycle should be present on PWM output 2, connector J8, pin 35.

Watchdog Timer Programming

Example: Watchdog Timer With Software Trigger

A software trigger relies on a thread of execution to constantly trigger watchdog timer A. If the thread is ever halted, timer A decrements to zero and starts timer B. Once timer B decrements to 0, the board resets.

In this example we set the watchdog timer to a countdown period of four seconds. Longer timeout periods are typically be used for a software-based watchdog timer, to accommodate varying software latencies, such as interrupt latencies and thread pre-emption, that may delay the watchdog trigger code.

Setting up the watchdog timer:

```
outp(base + 0, 0x00);           //set page 0
outp(base + 28, 40000 & 0xFF); //set LSB of WD timer A (4 seconds)
outp(base + 29, (40000 >> 8) & 0xFF); //set MSB of WD timer A
outp(base + 30, 0xFF);         //set WD timer B to 0.0255 seconds
outp(base + 31, 0x28);         //set WDEN=1, WDRST=1 (enable WD timer, reset)
```

With the timer setup and active, run the watchdog timer trigger in a continuous thread of code.

```
while (1)
{
    outp(base + 31, 0x80); //trigger watchdog timer
    sleep(1000);           //sleep one second
}
```

If this thread is interrupted for any reason, the board resets four seconds after the last watchdog timer trigger.

Example: Watchdog Timer With Hardware Trigger

A hardware trigger relies on an external pulse to constantly trigger watchdog timer A. If the external stream of pulses ever halts, timer A decrements to zero and starts timer B. Once timer B decrements to 0, the board resets.

In this example, we will make use of the T-1 feature of timer A to automatically reset itself unless a physical connection is broken. The physical connection must be made between WDO and WDI on the data acquisition header, J9.

Since software is not involved in maintaining the timer, we can set the reset period to a much smaller value. In this example, the reset pulse travels across the physical connection every 10 milliseconds.

```
outp(base + 0, 0x00);           //set page 0
outp(base + 28, 100 & 0xFF);    //set LSB of WD timer A (10 milliseconds)
outp(base + 29, 100 >> 8) & 0xFF); //set MSB of WD timer A
outp(base + 30, 0xFF);         //set WD timer B to 0.0255 seconds
outp(base + 31, 0x2D);         //set WDEN=1, WDRST=1, WDT-1=1, WDIEN=1
```

When timer A reaches 1, a rising edge flows from WDO to WDI, resetting the timer back to 100 and lowering WDO.

When the connection from WDO to WDI is broken, the rising edge never reaches WDI and system resets.

Data Acquisition Specifications (Data Acquisition units only)

Analog Inputs

- No. of inputs, 16 differential or 32 single-ended (user selectable)
- A/D resolution, 16 bits (1/65,536 of full scale)
- Input ranges,
 - Bipolar: $\pm 10\text{V}$, $\pm 5\text{V}$, $\pm 2.5\text{V}$, $\pm 1.25\text{V}$
 - Unipolar: $0-10\text{V}$, $0-5\text{V}$, $0-2.5\text{V}$
- Input bias current, 50nA max
- Maximum input voltage, $\pm 10\text{V}$ for linear operation
- Over-voltage protection, $\pm 35\text{V}$ on any analog input without damage
- Nonlinearity, $\pm 3\text{LSB}$, no missing codes
- Drift, 5PPM/ $^{\circ}\text{C}$ typical
- Conversion rate, 100,000 samples per second max
- Conversion trigger, software trigger, internal pacer clock, or external TTL signal
- FIFO, 48 samples; programmable interrupt threshold

Analog Outputs

- No. of outputs, 4
- D/A resolution, 12 bits (1/4096 of full scale)
- Output ranges,
 - Unipolar: $0-10\text{V}$ or user-programmable
 - Bipolar: $\pm 10\text{V}$ or user-programmable
- Output current, $\pm 5\text{mA}$ max per channel
- Settling time, $4\pm S$ max to $\square 1/2$ LSB
- Relative accuracy, ± 1 LSB
- Nonlinearity, ± 1 LSB, monotonic

Digital I/O

- No. of lines, 40 (32 dedicated DIO plus two configurable nibbles, 4-bits each)
- Compatibility, 3.3V and 5V logic compatible
- Input voltage, Logic 0: -0.5V min, 0.8V max; Logic 1: 2.0V min, 5.5V max
- Input current, $\pm 1\mu\text{A}$ max
- Output voltage, Logic 0: 0.0V min, 0.4V max; Logic 1: 2.4V min, 3.3V max
- Output current, Logic 0: 12mA max; Logic 1: -8mA max
- I/O capacitance, 10pF max

Counter/Timers

- A/D pacer clock, 24-bit down counter with optional external gate
- Pacer clock source, 10MHz, 100 kHz, or external signal
- General purpose, 16-bit down counter with optional external gate
- GP clock source, 10MHz, 100 KHz, or external signal

General

- Power supply, $+5\text{VDC} \pm 5\%$
- Current consumption, $0.7\text{A} - 1.1\text{A}$ typical
- Operating temperature, -40 to $+85^{\circ}\text{C}$
- Operating humidity, 5% to 95% non-condensing

FlashDisk Module

Hercules II EBX is designed to accommodate an optional solid-state FlashDisk module. This module contains 32MB to 4GB of solid-state non-volatile memory that operates like an IDE drive without requiring additional driver software support.

<i>Model</i>	<i>Capacity</i>
FD-32-XT	32MB
FD-64-XT	64MB
FD-128-XT	128MB
FD-256-XT	256MB
FD-512-XT	512MB
FD-1G-XT	1024MB
FD-2G-XT	2048MB
FD-4G-XT	4096MB

Figure 43: Flashdisk Module



Installing the FlashDisk Module

The FlashDisk module installs directly on the IDE connector, J16, and is held down with a spacer and two screws onto a mounting hole on the board.

The FlashDisk module contains a jumper for master/slave configuration. For master mode, install the jumper over pins 3 and 4. For slave mode, install the jumper over pins 1 and 2.

By default the BIOS autodetects the FlashDisk on the IDE. The FlashDisk must be in master mode.

Using the FlashDisk with Another IDE Drive

The FlashDisk occupies the board's 44-pin IDE connector and does not provide a pass-through connector. To utilize both the FlashDisk and a notebook drive, the Diamond Systems Corporation ACC-IDEEXT adapter and cables are required. To use the FlashDisk and a 40-pin IDE drive, such as a CD-ROM or 5.25" hard drive, both devices may be used simultaneously, since the 40-pin device uses a different I/O connector on the Hercules II EBX board.

Power Supply

The 44-pin cable carries power from the CPU to the adapter board and powers the FlashDisk module and any drive using a 44-pin connector, such as a notebook hard drive.

A drive utilizing a 40-pin connector, such as a CD-ROM or full-size hard drive, requires an external power source through an additional cable. The power may be provided from the CPU's power out connector, J12, or from one of the two 4-pin headers on the ACC-IDEEXT board. Hercules II EBX cable no. 698006 may be used with either power connector to bring power to the drive.

Utility Board

A small Utility board (DSC# 861002) is included with the Hercules II EBX cable kit, C-HRCEBX-KIT. This small board plugs onto the Utility connector, J7, and provides a simple interface for various buttons and LEDs.

- Power Button: Simple push-button for “Power Button” functionality.
- Reset Button: Push button causes system-wide hardware reset.
- Power LED: Lights when main system power is active. Stand-by power may still be active when this LED is off.
- Ethernet, 100MBit link LED: Lights when 100Mbit link is achieved. I does not illuminate for 10Mbit link.
- Ethernet, Activity LED: Pulses with Ethernet activity (reads or writes).
- IDE Activity LED: Lights when any access is made through the two on-board IDE connectors, and reflects activity of up to four devices potentially active through the two IDE connectors.
- Speaker: This speaker is a typical PC “Beep” speaker; it is not an output for the on-board sound system.

Figure 44: Utility Board

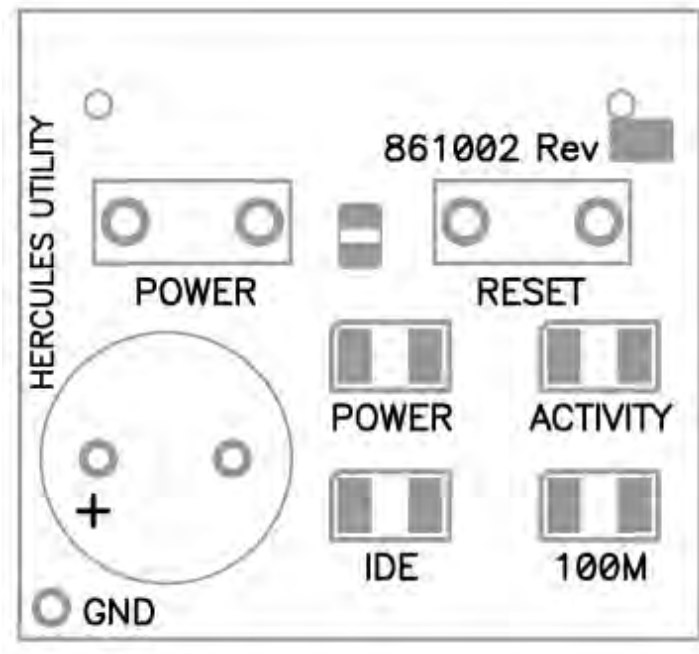

- Apply power to the main board by pressing *Power Button* on the utility board, if main board has been powered off using the on-board power control, and watch for the +5, +15, and -15 LEDs to become active.

The Board is now ready to use.

DAQ Board DIO interface

The Data Acquisition Test Board provides a complete loopback capability for each DIO bit. Each DIO signal can potentially be driven and read back by at least one other DIO channel. The details of this loopback are user-configurable for many DIO bits, as described below.

DIO A – DIO B Loopback

DIO channel A (bits 7-0) are looped back to DIO channel B (bits 7-0). A special case for this loopback is that bit 0 also goes to EXTTRIG.

In general, this loopback requires that one port be set as an output and the other port(s) set as an input. This is done on the Hercules II EBX using software. While there is some protection for the case when both are set as outputs, this should not be done and serves no useful purpose in testing.

This loopback is connected to a bank of eight LEDs on the test board. A given LED is active when the associated data bit is low. For example, if DIO channel A is set as an output and DIO channel B is set as an input then a value of 0xFE written to the DIO Channel A output register results in a value of 0xFE in the channel B input register, and causes the bit 0 LED to be ON while the rest of the DIO loopback LEDs are off.

DIO C – DIO D – DIOE Loopback

DIO channel C (bits 7-0) is looped back to DIO channel D (bits 7-0) and DIO channel E (bits 7-0), using the following switch bank SW1 switches for bits 7-4.

- Switch 1 is ON (E bit 4 connected to C bit 4 and D bit 4)
- Switch 2 is ON (E bit 5 connected to C bit 5 and D bit 5)
- Switch 3 is ON (E bit 6 connected to C bit 6 and D bit 6)
- Switch 4 is OFF (E bit 6 NOT connected to ACK output)
- Switch 5 is ON (E bit 7 connected to C bit 7 and D bit 7)

Note: Switch 6 does not affect DIO loopback and is used for watchdog timer functions.

To perform DIO loopback tests, ensure that one of the three channels is set as an output and the other two channels are set as inputs. Any data written to the output channel is read back on the two input channels.

There are several special cases for Channel E testing.

- Channel E, bits 3-0 can also be used for the PWM output function. In this case, channels C and D both need to be configured as inputs to avoid out-output contention. These PWM waveforms can be readily sampled using DIO Channel C, 3-0, or DIO Channel D, 3-0, or they can be manually measured at pins 1-4 on testpoint connector TP1.
- Channel E, bit 4 can also be used for the GATE1 function. It can be connected to DIO Channel C and D, bit 4, by setting SW1 switch 1 to the ON position. In this configuration, it is directly wired for DIO loop back to Channel C, bit 4, and Channel D, bit 4.
- To test GATE1 functionality, one of the other sources must be set as an output to assert the required signal or SW1 switch 1 can be set to the OFF position and an appropriate signal can drive the testpoint TP1, pin 4. This testpoint can be used for GATE1 probing and assertion.
- Channel E, bit 5, is wired to an LED on-board, as well as to SW1 switch 2. To loopback DIO E bit 5 to DIO C/D bit 5, set SW1 switch 2 to the ON position. To test TOUT1 functionality for DIO E, bit 5, either set both DIO D and C to input or set SW1 switch 2 to the OFF position. DIO E, bit 5, can be manually measured at TP1, pin 6.

- Channel E, bit 6, which is also used for LATCH signal functionality, can be independently connected to DIO channel C/D, bit 6, for DIO loopback testing, or the ACK output signal, for LATCH functional testing. Testpoint TP1, pin 7 can be used for DIO E, bit 6, LATCH probing and assertion.
 - For loopback testing, SW1 switch 3 should be set to ON and SW1 switch 4 should be set to OFF.
 - For LATCH/ACK testing, SW1 switch 4 should be set to ON and SW1 switch 3 should be set to OFF.
- Channel E, bit 7, can also be used for the GATE0 function. It can be connected to DIO Channel C and D, bit 4, by setting SW1 switch 5 to the ON position. In this configuration, it is directly wired for DIO loop back to Channel C, bit 7, and Channel D, bit 7. Testpoint TP1, pin 8, can be used for GATE0 probing and assertion.

Special Functions

As discussed previously, Channel E can be used for alternative functions for the DIO interface. There are several dedicated signals for some of these special functions.

GATE0

The GATE0 signal is used to enable the internal counter 0 of the FPGA when in *gated mode*. A high input enables counting and a low input disables counting. This signal is multiplexed with Channel E, bit 7, which means that this input is tied directly to Channel D, bit 7, and channel C, bit 7, when SW1 switch 5 is ON. To test this special function input, either one of these DIO channels, C or D, must be set as an output and bit 7 of the output channel must be used to control this gating function.

Alternatively, an external source can be used. In this case, SW1 switch 5 should be set to OFF and an external gating signal should be driven in to TP1, pin 8.

GATE1

The GATE1 signal is used to enable the internal counter 1 of the FPGA when in *gated mode*. A high input enables counting and a low input disables counting. This signal is multiplexed with Channel E, bit 4, which means that this input is tied directly to Channel D, bit 4, and channel C, bit 4, when SW1 switch 1 is ON. To test this special function input, either one of these DIO channels, C or D, must be set as an output and bit 4 of the output channel must be used to control this gating function.

Alternatively, an external source can be used. In this case, SW1 switch 1 should be set to OFF and an external gating signal should be driven in to TP1, pin 5.

- TOUT0: This signal is used as a timer out from the FPGA timer 0 control. It is a dedicated output and is tied to an LED and testpoint TP1, pin 12, for probing.
- TOUT1: This signal is used as a timer out from the FPGA timer 1 control. It is multiplexed with Channel E, bit 5, and is wired directly to Channel D, bit 5, and Channel C, bit 5, as well as to an LED. If the TOUT1 function is required, the two attached DIO signals (D, bit 5, and C, bit 5) must be configured as inputs. TOUT” is also tied to testpoint TP1, pin6, for probing.
- DIOLATCH/ACK: The LATCH signal is multiplexed with DIO Channel E, bit 6. The output is connected directly to the dedicated ACK signal using SW1 switch 4, so DIO feedback can be directly supported for testing. If this is selected, SW1 switch 3 should be set OFF to avoid conflicts, such as DIO C/D. bit 6. unintentionally driving DIOLATCH.
- EXTTRIG: This is a dedicated input signal which is used for latching data or as a clock or pulse source for the internal counter 1. This is connected directly to testpoint TP1; pin 10, Channel A, bit 0, Channel B, bit 0, as well as two switches:
 - SW1 switch 3, which routes EXTTRIG to DIO E5/TOUT1.
 - SW1 switch 4, which routes EXTTRIG to TOUT0.
- There are several ways to test EXTTRIG, given the following connections.
 - *Use TOUT0 to drive EXTTRIG.* In this case, SW1 switch 3 should be OFF, SW1 switch 4 should be ON, DIO ports A and B should both be configured as input, and TOUT0 should be configured to generate the desired output.
 - *Use TOUT1 to drive EXTTRIG.* In this case, SW1 switch 3 should be ON, SW1 switch 4 should be OFF, DIO ports A and B should both be configured as input, and TOUT1 should be configured to generate the desired output, making sure that DIO Channel E7-4 are configured for alternate functions.

- *Use DIO A, bit 0, to drive EXTTRIG.* In this case, SW1 switch 3 should be OFF, SW1 switch 4 should be OFF, DIO port B should both be configured as input, and DIO port A should be configured as output. Data written to DIO port A, bit 0, controls the EXTTRIG function.
- *Use DIO B, bit 0, to drive EXTTRIG.* In this case, SW1 switch 3 should be OFF, SW1 switch 4 should be OFF, DIO port A should both be configured as input, and DIO port B should be configured as output. Data written to DIO port B, bit 0, controls the EXTTRIG function.
- *Use external trigger source.* In this case, SW1 switch 3 should be OFF, SW1 switch 4 should be OFF, DIO ports A and B should both be configured as input, and DIO port B should be configured as output. The external trigger source should be connected using TP1, pin 10.
- There are 4 channels of PWM output that can be independently controlled. These four channels are present on Channel E, bits 3-0, when the PWM functions are enabled. Frequency and duty cycle can be varied for each channel.

Note: Be certain that the DIP switches for the DIOLATCH/ACK handshaking are correctly configured on the DAQ Test Board before beginning any testing of these functions. If a DIO is inadvertently connected to this loopback, anomalous behavior may result. As mentioned above for LATCH/ACK testing, SW1 switch 4 should be set ON and SW1 switch 3 should be set OFF.

DAQ Board Analog Testing

Analog Output Connections

There are four output channels (VOUT3-0) from the main Hercules II EBX board. These channels are capable of full-rail, $\pm 10\text{V}$, output, and are looped back to input channels for testing.

- VOUT 0 connected to VIN9 and VIN 12 (both buffered); Also, inverted to VIN10
- VOUT 1 connected to VIN13
- VOUT 2 connected to VIN14
- VOUT 3 connected to VIN15

Analog Input Connections

There are 32 single-ended analog input channels, or 16 differential input channels. These channels are configured as shown in the following table.

<i>Channel</i>	<i>Description</i>	<i>Channel</i>	<i>Description</i>
VIN 0	Ground (0 V)	VIN 16	Ground (0 V)
VIN 1	“Vlowref” (2.2mV)	VIN 17	Ground (0 V)
VIN 2	“+Vref-L” (1.1161V)	VIN 18	Ground (0 V)
VIN 3	(2.39V)	VIN 19	Ground (0 V)
VIN 4	“+Vref-H” (4.7768V)	VIN 20	Ground (0 V)
VIN 5	“V+” (9.5536V)	VIN 21	Ground (0 V)
VIN 6	“V-“ (-9.5536V)	VIN 22	Ground (0 V)
VIN 7	Ground (0 V)	VIN 23	“V-“ (-9.5536V)
VIN 8	Ground (0 V)	VIN 24	(7.961V)
VIN 9	VOUT 0 (buffered)	VIN 25	(6.369V)
VIN 10	-VOUT 0 (buffered)	VIN 26	(3.185V)
VIN 11	Ground (0 V)	VIN 27	(1.592V)
VIN 12	VOUT 0 (buffered)	VIN 28	(-1.592V)
VIN 13	VOUT 1	VIN 29	(-3.185V)
VIN 14	VOUT 2	VIN 30	(-6.369V)
VIN 15	VOUT 3	VIN 31	(-7.961V)

General DAQ Testing Suggestions and Comments

Considering differential bipolar/unipolar settings, note the differential pairs in the table, above. Specifically, note that VIN5+ is connected to +9.5V and VIN5- is ground; VIN6+ is -9.5V and VIN6- is ground. If the A/D inputs are configured for differential mode and all voltages appear correct up to VIN6 (i.e., VIN0-3 is correct, and you get a reading of +9.5V for VIN5 but VIN6 reads 0V), this is a good indication that the inputs are configured for unipolar mode (i.e., negative differential voltage is not reported). Similarly, voltage readings for channels VIN8 and VIN11 are also incorrect and readings for VIN9, VIN10, VIN12, VIN13, VIN14, and VIN15 may not be correct, depending on whether or not the output voltage is higher than the associated *low-side* differential voltage for the given input channel.

Note: Due to cable length and relative board location, some outputs may show more noise/inaccuracy than others. The data acquisition test board is intended to verify basic functionality and connection, including auto-calibration features. It is not intended to provide perfect response for signal performance characterization.

FlashDisk Programmer Board

The FlashDisk Programmer Board accessory, model no. ACC-IDEEXT, may be used for several purposes. Its primary purpose is to enable the simultaneous connection of both a FlashDisk module and a standard IDE hard drive or CD-ROM drive, to allow file transfers to/from the FlashDisk. This operation is normally done at system setup. The board can also be used to enable the simultaneous connection of two drives to the CPU.

Connector J1 connects to the IDE connector on Hercules II EBX with a 44-pin ribbon cable (Diamond Systems Corporation part no. 698004). Both 40-pin .1-inch spacing, J4, and 44-pin 2mm spacing, J3, headers are provided for the external hard drive or CD-ROM drive. A dedicated connector, J2, is provided for the FlashDisk module. Any two devices may be connected simultaneously using this board with proper master/slave jumper configurations on the devices.

The FlashDisk Programmer Board comes with a 44-wire cable no. (DSC no. 698004) and a 40-wire cable no. (DSC no. C-40-18) for connection to external drives. The FlashDisk module is sold separately.

The 44-pin connector (J1, J2 and J3) and mating cable carry power, but the 40-pin connector (J4) and mating cable do not. Connectors J5 and J6 on the accessory board may be used to provide power to a 44-pin device attached to the board when the board is attached to a PC via a 40-pin cable. These headers are compatible with the floppy drive power connector on a standard PC internal power cable.

Figure 46: FlashDisk Programmer Board Layout

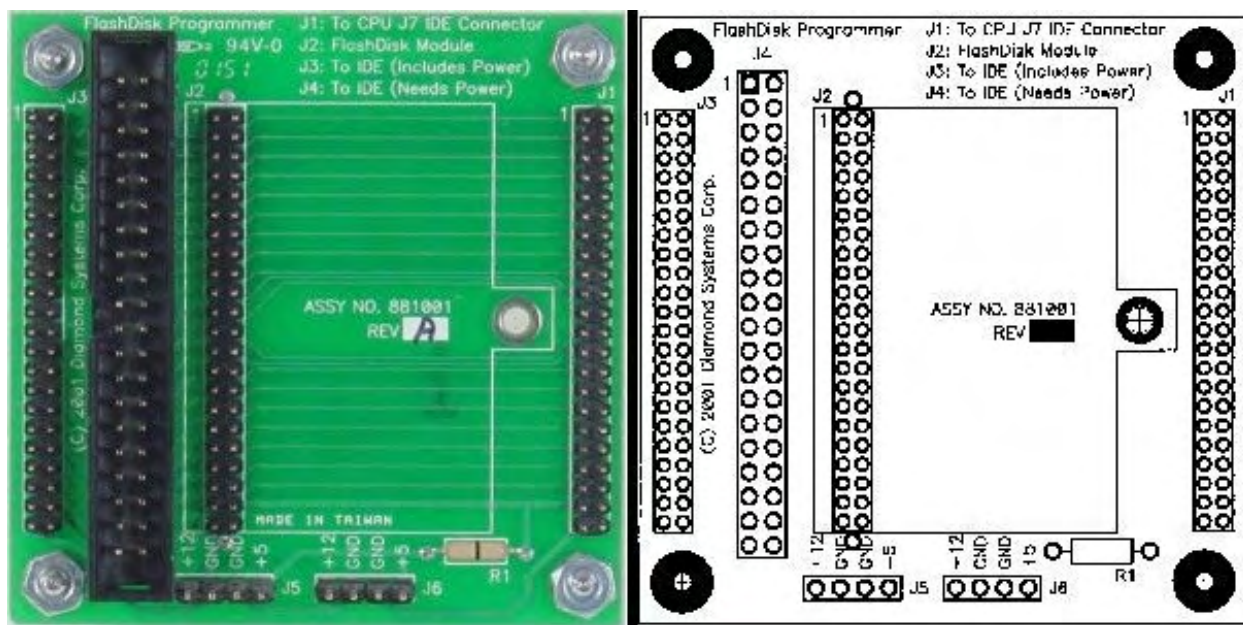

I/O Cables

For custom installations as well as development, Diamond Systems Corporation offers a cable kit no. <DSC# C-HRCEBX-KIT> with 18 types of cables to connect to all I/O headers on the board. Some cables are also available separately.

Note: When the multi-I/O cable (DSC# C-DB9M-4) or any other cable is connected to serial ports 1, 2, 3 or 4, the serial port signals must terminate to another board or interference problems may occur that will slow down the performance of your CPU.

The following table lists Cable Kit (DSC#C-HRCEBX-KIT) and references the cable photographs in Figure 47.

<i>Photo No.</i>	<i>Cable No.</i>	<i>Description</i>
1	C-PRZ-02	(OPTIONAL) 6-wire Ethernet cable with panel-mount RJ-45 connector.
2	698022	PS/2 Connector for Mouse and Keyboard with PS/2 mini-DIN connectors.
3	698025	Audio I/O Cable (for line-level and microphone audio).
4	698017	TV out cable (S-Video mini-DIN and Composite RCA jack output) NTSC-only.
5	698018	Amplified audio output (Speaker out), with volume control signals with stripped/tinned leads.
6	698024	VGA Ribbon cable to VGA Female DB15 for monitor out.
7	C-20-18	18-inch ribbon cable for "Utility" connections (includes power and reset contacts).
8	C-40-18	40-wire data acquisition ribbon cable (Analog I/O).
9	C-50-18	50-wire data acquisition ribbon cable (Digital I/O).
10	C-DB9M-4	40-pin ribbon cable to 4-serial port male DE-9 connectors.
11	698026	UDMA/ATA-100 cable for 1 or 2 IDE drives.
12	698004	44-wire IDE cable for 1 or 2 laptop-style drives.
13	698015	Standard (low-voltage) input power cable with stripped/tinned leads for connection to external power source.
14	698016	(OPTIONAL) High-Voltage DC power input cable.
15	698001	External (3V) Battery power cable.
16	698006	4-wire output power cable for external drives.
17	698012	Dual USB cable.
18	861002	Utility Board (used instead of C-20-18 for development).

Figure 47: Cable Kit

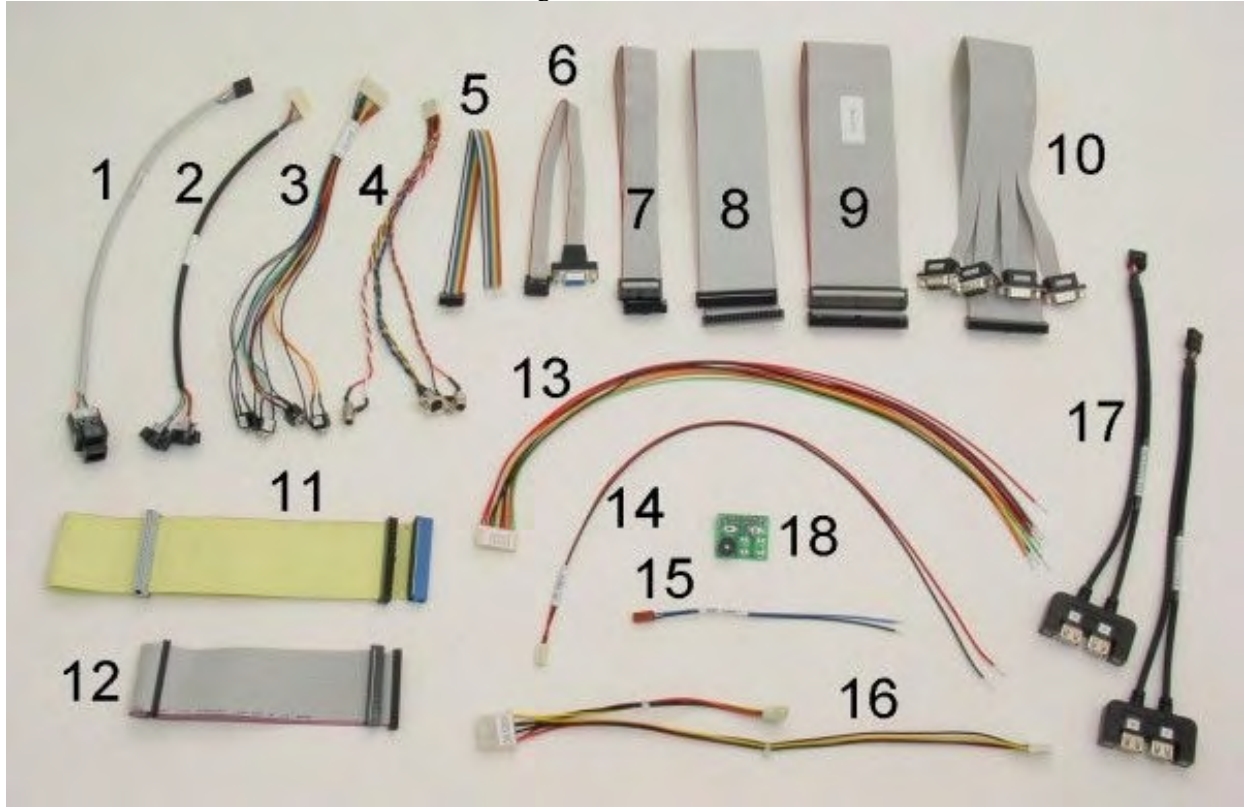

Mounting PC/104(+) Cards onto a Hercules II EBX Baseboard

Hercules II EBX is designed to serve as a baseboard for a stack of PC/104 or PC/104-*Plus* boards. Up to four PC/104-*Plus* boards are supported with the top-most board only supporting slave-mode PCI; no bus mastering is supported for that board. Any PC/104 boards should be mounted on top of the PC/104-*Plus* board stack, when both board types are to be combined. (This should be obvious, given the lack of PC/104-*Plus* stack-through connectors on a standard PC/104 board).

PC/104-*Plus* requires a board configuration setting for each board in a PC/104-*Plus* board stack. Ensure that the lowest board in the stack is assigned to the lowest board ID, as per the PC/104-*Plus* specification. This setting establishes the PCI Clock, PCI Interrupt routing, the Bus Master signals, and the device ID setting for PCI configuration. These settings are critical. Two boards should never be configured with identical board stack settings, because this will result in problems accessing PCI devices and may cause damage to the main board and/or the PC/104-*Plus* boards in the stack.

Note: Do not configure two PC/104-*Plus* boards with the same board stack ID!

PC/104 is much less critical in this regard, but care should be taken to ensure that the ISA resource allocations allow space for the specific boards added in the stack. Resources (IRQs, in particular) can be very limited in a system with so many devices present on the main board. It is important to ensure that ISA I/O, Memory, IRQ, and DMA configuration conflicts are resolved before powering-up the system. Otherwise, it is possible that the system boot sequence will be impeded by these conflicts.

Take care to read through this documentation, particularly the section on ISA Resource defaults, to familiarize yourself with the internal resources used before adding components that might cause conflicts.

When adding boards to the PC/104(+) board stack, be sure to include board standoff. Inordinate flexing of the main PC/104 and PC/104-*Plus* connectors can seriously reduce the effective lifespan of the connectors, as well as cause potential system instability due to incomplete connection across system buses.

CompactFlash

There is a CompactFlash connector located on the bottom of the board, under J34. A CompactFlash card placed in this slot is recognized and treated as an IDE device. A CompactFlash card can be used as the boot device for a system. The Compact Flash installation requires that no cable connections to connector J17.

No other IDE devices are supported on this channel when a CompactFlash card is installed, so the Primary IDE channel is still available.

The board is not configured for CompactFlash support by default. To enable CompactFlash, add a jumper to J5, to enable MASTER support. With the jumper added, any card placed in the CompactFlash slot should be detected as an IDE device upon boot-up.

NOTE: Do not add or remove a CompactFlash card while the board is powered-up. Either remove power from the entire system or power the board off before making these changes.

Customization Options

There are many customer-specific customizations that can be done for the Hercules II EBX, including:

- Latching connectors (replacing the box headers used for most of the board I/O connections).
- Connectors with extra gold contact plating.
- Alternative heatsinks for low air-flow and dusty environments.
- Conformal Coating.
- Jumperless configuration (all settings made on-board with no jumper headers required).

Contact your sales representative for details on these special-order options.

Specifications

CPU

- Processor: VIA Mark CoreFusion™ CPU
- Speed: 800MHz
- Power consumption: 10W
- Cooling: Heat sink, no fan
- Chipset: VIA VT8606 (Mark internal) + 82C686B
- Memory: 256/512MB (depending on configuration)
- Bus interface: PC/104-Plus (ISA + PCI)
- Display type: CRT and / or LVDS flat panel
- Resolution: 1600 x 1200
- Video memory: 32MB UMA
- USB ports: (4) USB 2.0, (4) USB 1.1
- Serial ports: (2) RS232 and (2) RS232/422/485
- Networking: 10/100BaseT Ethernet
- Mass storage interfaces: (2) IDE UDMA 100
- Keyboard/mouse: PS/2
- Audio: AC '97, Line-in, Line-Out, Mic and amplified speaker interface

Data Acquisition Circuitry

- Analog inputs: (32) 16-bit A/D resolution
- Max sample rate: 250KHz total
- Input modes: Single-ended, differential
- Input ranges: $\pm 10V$, $\pm 5V$, $\pm 2.5V$, $\pm 1.25V$, $0-10V$, $0-5V$, $0-2.5V$, $0-1.25V$,
- Accuracy: $< \pm 2LSB$ after autocalibration
- Analog outputs: (4) 12-bit D/A resolution
- Settling time: $7\mu S$ to $\pm 0.01\%$
- Output current: $\pm 5mA$ max, $2k\Omega$ min load
- Digital I/O: 40 lines, 5v logic compatible
- Direction: Programmable in 8-bit ports
- Output current: 0: 12mA max; 1: -4mA max
- Counter/timers: (1) 24-bit A/D sample rate control; (1) 16-bit general purpose

Power Supply

- Input Voltage: 5-28VDC standard, 20-48VDC optional
- Output power: 40W total, 30W available
- Power consumption: 10W
- Output voltages: +5V, +3.3V (on PCI bus)
- Switched outputs: +5V, +12V, +3.3V

General

- Dimensions: 8.00" X 5.75" (EBX)
- RoHS: 77mA @ 5V – 385 mW (without modules)
- Operating temperature: -40° to $+85^{\circ}$ C
- Weight:

Additional Information

Additional information can be found at the following websites.

1. Diamond Systems Corporation <http://www.diamondsystems.com/>

Appendix A - Hercules and Hercules II Differences

The following summarizes the differences between the 1st generation Hercules board and the Hercules II board.

- Hercules II uses the Via Mark Corefusion Processor Memory, which includes an integrated North Bridge and features reduced power consumption.
- Processor is 800MHz fanless vs. 550MHz fanless / 750MHz with fan
- Memory size is increased to 256/512MB (depending on configuration) instead of 128/256MB.
- Support for the disk-on-chip feature has been removed.
- Four additional USB 2.0 ports are added (total 8 USB ports).
- COM3 and COM4 support RS-232, RS-422 and RS-485 protocols instead of RS-232 and RS-485, only.
- COM4 can be configured to use IRQ7.
- Hercules II is RoHS compliant.

An image of the first generation Hercules board is shown below. Note the significant areas of change for the second generation product.

Figure 48: Differences Between Hercules and Hercules II Boards

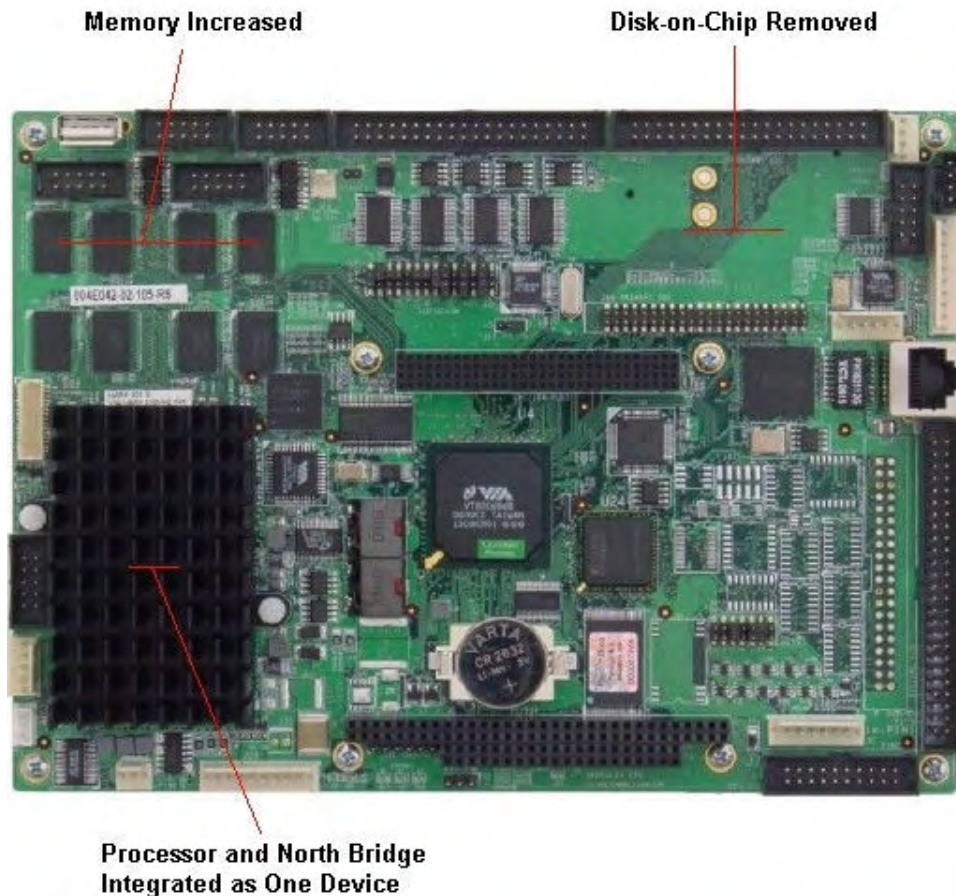

Technical Support

For technical support, please email support@diamondsystems.com or contact Diamond Systems Corporation technical support at 1-650-810-2500.