

Xtreme/SBC PCI-104 & PCI-104 Qseven Carrier Board

User Manual



Connect Tech Inc.
42 Arrow Road
Guelph, Ontario
N1K 1S6

Tel: 519-836-1291
Toll: 800-426-8979 (North America only)
Fax: 519-836-4878
Email: sales@connecttech.com
support@connecttech.com
Web: www.connecttech.com

Table of Contents

Customer Support Overview	4
Contact Information.....	4
Limited Lifetime Warranty.....	5
Copyright Notice	5
Trademark Acknowledgment	5
Revision History	5
Introduction	6
Features.....	6
What is Qseven?	6
System Block Diagram	7
Hardware Description.....	8
Connector Locations	8
Qseven Module Interface	9
Description.....	9
Connector.....	9
Graphics.....	9
VGA.....	9
Description.....	9
Connector.....	9
LVDS.....	10
Description.....	10
Connectors & Jumpers.....	10
Gigabit Ethernet.....	13
Description.....	13
Connector & LEDs	13
USB 2.0.....	14
Description.....	14
Connector.....	14
SATA.....	15
Description.....	15
PCI-104.....	16
Description.....	16
Connectors	16
LPC Super I/O	17
Serial.....	17
Description.....	17
Connectors	18
PS/2 Keyboard and Mouse.....	19
Description.....	19
Connectors & Jumpers.....	19
Power.....	20
Description.....	20
Connectors & Jumpers.....	20
Fan Control	22
Description.....	22
Connectors & Jumpers.....	22

Battery.....	23
Description.....	23
Connector & LEDs	23
Hardware Installation	24
Software Installation & Configuration	25
Operating System Notes.....	25
Linux.....	25
General.....	25
US15W Specific	25
Windows	25
General.....	25
US15W Specific	25
Cables & Interconnect	26
Dimensions	27
Specifications	28

Customer Support Overview

If you experience difficulties after reading the manual and/or using the product, contact the Connect Tech reseller from which you purchased the product. In most cases the reseller can help you with product installation and difficulties.

In the event that the reseller is unable to resolve your problem, our highly qualified support staff can assist you. Our support section is available 24 hours a day, 7 days a week on our website at: www.connecttech.com/sub/support/support.asp. See the contact information section below for more information on how to contact us directly. Our technical support is always free.

Contact Information

We offer three ways for you to contact us:

Mail/Courier

You may contact us by letter at:
Connect Tech Inc.
Technical Support
42 Arrow Road
Guelph, Ontario
Canada N1K 1S6

Email/Internet

You may contact us through the Internet. Our email and URL addresses on the Internet are:

sales@connecttech.com
support@connecttech.com
www.connecttech.com

Note:

Please go to the [Download Zone](#) or the [Knowledge Database](#) in the [Support Center](#) on the Connect Tech website for product manuals, installation guides, device driver software and technical tips. Submit your technical support questions to our customer support engineers via the [Support Center](#) on the Connect Tech website.

Telephone/Facsimile

Technical Support representatives are ready to answer your call Monday through Friday, from 8:30 a.m. to 5:00 p.m. Eastern Standard Time. Our numbers for calls are:

Toll Free: 800-426-8979 (North America only)
Telephone: 519-836-1291 (Live assistance available 8:30 a.m. to 5:00 p.m. EST, Monday to Friday)
Facsimile: 519-836-4878 (on-line 24 hours)

Limited Lifetime Warranty

Connect Tech Inc. provides a Lifetime Warranty for all Connect Tech Inc. products. Should this product, in Connect Tech Inc.'s opinion, fail to be in good working order during the warranty period, Connect Tech Inc. will, at its option, repair or replace this product at no charge, provided that the product has not been subjected to abuse, misuse, accident, disaster or non-Connect Tech Inc. authorized modification or repair.

You may obtain warranty service by delivering this product to an authorized Connect Tech Inc. business partner or to Connect Tech Inc. along with proof of purchase. Product returned to Connect Tech Inc. must be pre-authorized by Connect Tech Inc. with an RMA (Return Material Authorization) number marked on the outside of the package and sent prepaid, insured and packaged for safe shipment. Connect Tech Inc. will return this product by prepaid ground shipment service.

The Connect Tech Inc. Lifetime Warranty is defined as the serviceable life of the product. This is defined as the period during which all components are available. Should the product prove to be irreparable, Connect Tech Inc. reserves the right to substitute an equivalent product if available or to retract Lifetime Warranty if no replacement is available.

The above warranty is the only warranty authorized by Connect Tech Inc. Under no circumstances will Connect Tech Inc. be liable in any way for any damages, including any lost profits, lost savings or other incidental or consequential damages arising out of the use of, or inability to use, such product.

Copyright Notice

The information contained in this document is subject to change without notice. Connect Tech Inc. shall not be liable for errors contained herein or for incidental consequential damages in connection with the furnishing, performance, or use of this material. This document contains proprietary information that is protected by copyright. All rights are reserved. No part of this document may be photocopied, reproduced, or translated to another language without the prior written consent of Connect Tech, Inc.

Copyright © 1997 - 2011 by Connect Tech, Inc.

Trademark Acknowledgment

Connect Tech, Inc. acknowledges all trademarks, registered trademarks and/or copyrights referred to in this document as the property of their respective owners.

Not listing all possible trademarks or copyright acknowledgments does not constitute a lack of acknowledgment to the rightful owners of the trademarks and copyrights mentioned in this document.

Revision History

Revision 0.00 – January 10, 2011

Introduction

Connect Tech's Xtreme/SBC PCI-104 is a small embedded carrier board that utilizes the PCI-104 form factor, which has the standard PC/104 dimensions and can support up to four PCI-104 add-on boards. This carrier board includes the required connectors and cables for easy connection to 2x SATA, 2x RS-232, 2x RS-422/485, 4x USB 2.0, 1x Gigabit Ethernet, LVDS and VGA Video.

The Xtreme/SBC PCI-104 allows complete integration with any industry standard Qseven module, transforming it into a robust Single Board Computer (SBC) in the PC/104 form factor. Xtreme/SBC PCI-104 is ideal for a broad range of embedded applications. The Qseven standard allows upgrading to the latest processor and memory technology with ease, while maintaining the I/O interfaces.

Features

- Qseven module carrier
- PCI-104 form factor
- Support for up to 4 PCI-104 Devices
- Dual display, VGA (via SDVO) and 1x24 LVDS
- 2x SATA
- 2x RS232
- 2x RS485
- 1x 10/100/1000 Ethernet
- ATX power input or +5V/+12V only operation

What is Qseven?

Qseven is a standard that enables integration of Computer-on-Modules with mobile and embedded applications. To learn more about Connect Tech's Xtreme/SBC PCI-104, visit <http://www.connecttech.com/sbc>.

System Block Diagram

The Qseven module implements the core processing features including: processor, memory, and system physical interfaces via the southbridge.

Many of the Qseven modules are based on the mobile Intel Atom architecture (Z series processor + Poulsbo / SCH US15W chipset); shown in the block diagram below.

This document will generally refer to the features of the US15W.

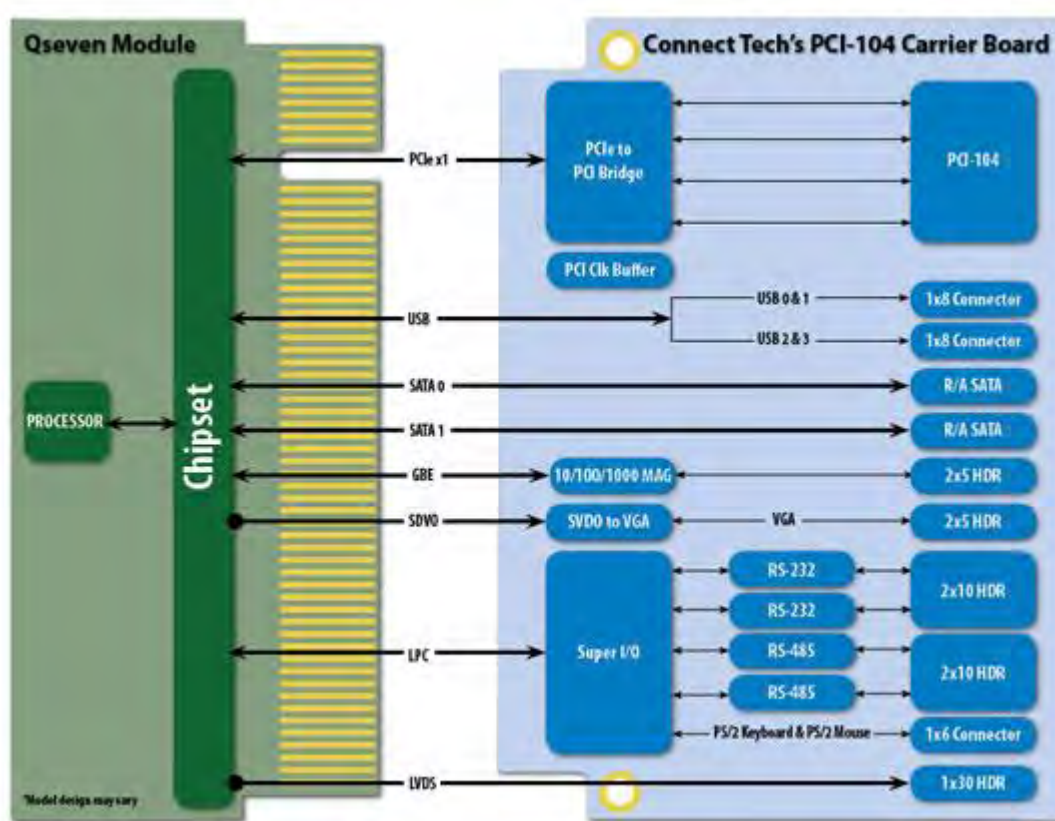

Hardware Description

Connector Locations

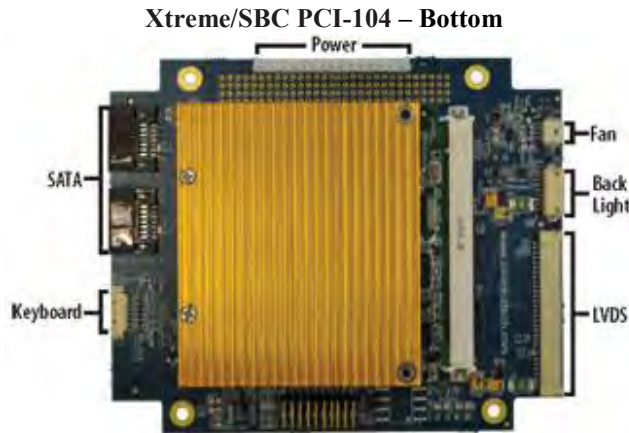

Connector Summary

Location	Connection
P1	Q7
P2	PCI-104
P3A, P3B	USB
P4	GBE
P5	VGA
P6	ATX Power
P7	LVDS Video
P8	LVDS Backlight
P9	RS232 serial
P10A, P10B	SATA
P11	RS485 serial
P12	PCI-104
P13	PS/2 Keyboard & Mouse
P14	Fan Power
P16	Battery holder

Jumper Summary

Jumper	Function
J1	PS/2 power
J2	Fan Power
J3	Fan PWM polarity
J4	LVDS panel power
J5	LVDS backlight enable polarity
J6	LVDS Backlight Power
J7	Suspend Selection
J8	Power Supply On
J9	Power Button

Qseven Module Interface

Description

The processor & Chipset is implemented on the Qseven CPU module, which connects to the Xtreme/SBC PCI-104 via a MXM connector. As previously mentioned, many of the existing Qseven Modules use the Intel Atom mobile architecture, Z series processor + Poulsbo / SCH US15W chipset. The Xtreme/SBC PCI-104 implements a subset of the Qseven features, as describe in the introduction.

For a list of Qseven module vendors, visit <http://www.qseven-standard.org/>

Connector

Function	Qseven interface
Location	P1
Type	MXM Foxconn AS0B326-S78N-7F (or equivalent)
Pinout	Refer to Qseven specification

Graphics

The availability of the graphics interfaces depends on the Qseven module selected.

US15W: The US15W chipset provides GMA 500 graphics sub-system and provides two display interfaces: SDVO (serial digital video output) and LVDS (low voltage differential signalling). The resolution is generated by the by GMA 500 is limited 1280x1024.

The configuration of either interface as the primary or secondary display depends on the Qseven module's BIOS capabilities and settings. Refer to the Qseven module's documentation for more details.

VGA

Description

The VGA interface is implemented using the Qseven SDVO interface, with a SDVO to VGA converter (Chrontel CH7317B) which supports resolutions up to 1920x1200; however actually resolutions depend on the Qseven module.

Connector

Function	VGA graphics			
Location	P5			
Type	2x5 2mm header MLE TSHSM-205-D-06-G-V-L (or equivalent)			
Pinout	Pin	Signal	Pin	Signal
	1	DAC_RED	2	GND
	3	DAC_GREEN	4	N/C
	5	DAC_BLUE	6	SC_DDC
	7	HSYNC	8	SD_DDC
	9	VSYNC	10	GND



LVDS

Description

The Xtreme/SBC PCI-104 provides dual 18 or 24 bit LVDS display channels via P7, which are connected directly from the Qseven module. LVDS panel supply power is selected with jumper J4 and backlight power is selected with jumper J6. Both are current limited to 500 mA.

US15W: The US15W provides only a single 18 or 24 bit display channel. Each LVDS data pair carries two bits, each channel has four data pairs.

Connectors & Jumpers

Function	LVDS Graphics		
Location	P7		
Type	Hirose DF14-30P-1.25H connector		
Pinout	Pin	Signal	Description
	1	VCC_PNL	Panel Power
	2	VCC_PNL	Panel Power
	3	GND	Digital ground
	4	GND	Digital ground
	5	LVDS_A3_N	Channel A Data
	6	LVDS_A3_P	Channel A Data
	7	LVDS_CLK_N	Channel A Clock
	8	LVDS_ACLK_P	Channel A Clock
	9	GND	Digital ground
	10	LVDS_A2_N	Channel A Data
	11	LVDS_A2_P	Channel A Data
	12	LVDS_A1_N	Channel A Data
	13	LVDS_A1_P	Channel A Data
	14	LVDS_A0_N	Channel A Data
	15	LVDS_A0_P	Channel A Data
	16	GND	Digital ground
	17	LVDS_B3_N	Channel B Data
	18	LVDS_B3_P	Channel B Data
	19	LVDS_BCLK_N	Channel B Clock
	20	LVDS_BCLK_P	Channel B Clock
	21	GND	Digital ground
	22	LVDS_B2_N	Channel B Data
	23	LVDS_B2_P	Channel B Data
	24	LVDS_B1_N	Channel B Data
	25	LVDS_B1_P	Channel B Data
	26	LVDS_B0_N	Channel B Data
	27	LVDS_B0_P	Channel B Data
	28	GND	Digital ground
	29	LVDS_DID_CLK	Display ID Clock (3.3V)
	30	LVDS_DID_DATA	Display ID Data (3.3V)

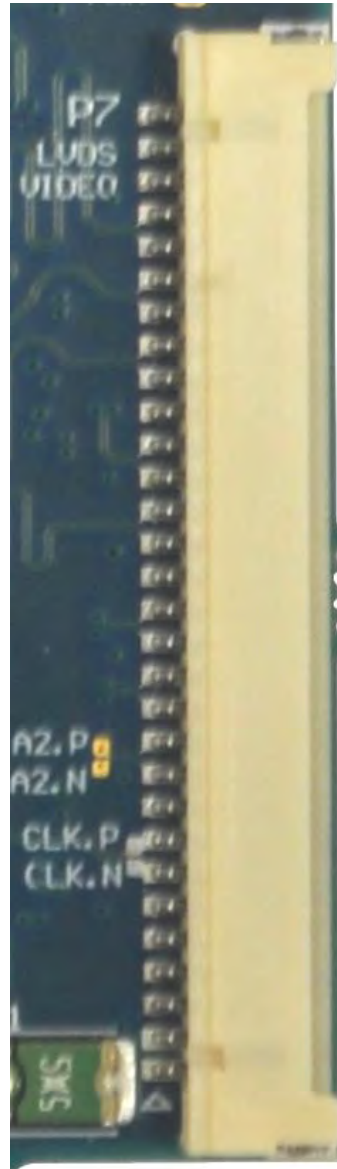

Function	LVDS backlight power		
Location	P8		
Type	Hirose DF13-8P-1.25H connector		
Pinout	Pin	Signal	Description
	1	+12V	+12 V DC, max. 1A
	2	+12V	+12 V DC, max. 1A
	3	+5V	+5 V DC, max. 1A
	4	+5V	+5 V DC, max. 1A
	5	LVDS_BLEN	Backlight enable, level selected with J4
	6	VCC_BKL	Back light power, selected with J6
	7	GND	Digital ground
	8	GND	Digital ground

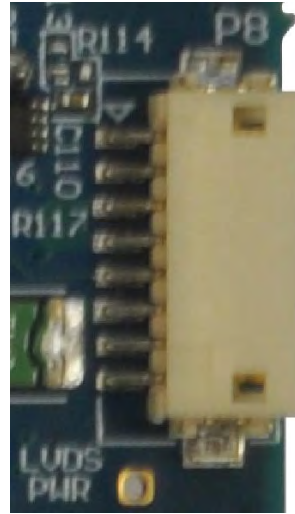

Function	LVDS backlight power select Selects either +12V or +5V. Refer to the display panel's documentation for proper configuration.	
Location	J6	
Type	1x3 0.100" jumper block	
Pinout	Position	Description
	1-2	+12V
	2-3	+5V
	off	floating
Default	+12V	

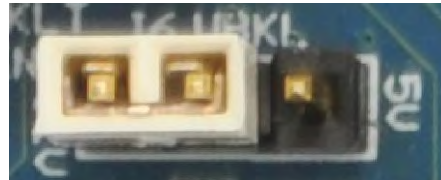

Function	LVDS panel power select Selects either +3.3V or +5V. Refer to the display documentation for proper configuration.	
Location	J4	
Type	1x3 0.100" jumper block	
Pinout	Position	Description
	1-2	+3.3V
	2-3	+5V
	off	floating
Default	+3.3V	

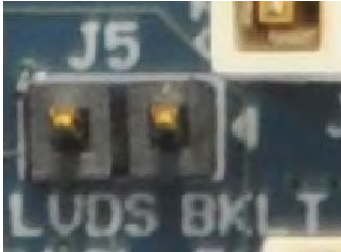

Function	LVDS backlight enable polarity Selects either positive or negative. Refer to the inverter power supply documentation for proper configuration.							
Location	J5							
Type	1x2 2mm jumper block							
Pinout	<table border="1"> <thead> <tr> <th>Position</th> <th>Description</th> </tr> </thead> <tbody> <tr> <td>off</td> <td>Positive polarity</td> </tr> <tr> <td>on</td> <td>Negative polarity</td> </tr> </tbody> </table>		Position	Description	off	Positive polarity	on	Negative polarity
Position	Description							
off	Positive polarity							
on	Negative polarity							
Default	Positive polarity							

Gigabit Ethernet

Description

The gigabit Ethernet interface's controller (MAC + PHY) is implemented on the Qseven module, while the Xtreme/SBC PCI-104 provides the necessary magnetics and termination.

Most Qseven modules support 1000BASE-T, 100BASE-TX, and 10BASE-T standards with either a Realtek 8111 or Intel 82574 PCIe Ethernet controller.

Connector & LEDs

Function	Gigabit Ethernet					
Location	P8					
Type	2x5 2mm header MLE TSHSM-205-D-06-G-V-L (or equivalent)					
Pinout	Pin	Signal	Description	Pin	Signal	Description
	1	MX1-	Data	2	MX1+	Data
	3	MX2-	Data	4	MX2+	Data
	5	FGND	Frame Ground	6	FGND	Frame Ground
	7	MX3-	Data	8	MX3+	Data
	9	MX4-	Data	10	MX4+	Data

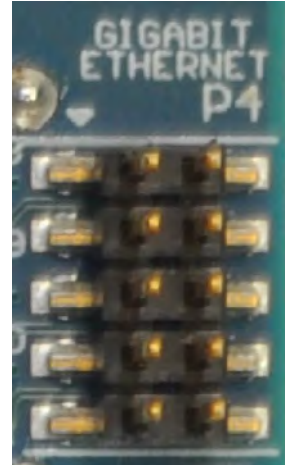

Function	Ethernet Status LEDs	
Locations	Pin	Signal
	D9	Activity
	D10	1000BASE-T Link
	D11	100BASE-TX Link
	D12	10BASE-T Link



USB 2.0

Description

The Xtreme/SBC PCI-104 implements 4 of the 8 available USB 2.0 connections via two connectors. Over current protection and power supply filtering is provided.

Only the USB host features of the Qseven specification have been implemented, USB client features are not supported.

Connector

Function	USB 2.0 x2																													
Locations	P3A, P3B																													
Type	Hirose DF13-8P																													
Pinout	<table border="1"> <thead> <tr> <th>Pin</th> <th>Signal</th> <th>Description</th> </tr> </thead> <tbody> <tr> <td>1</td> <td>VCC_USB_0</td> <td>Port 0 Filtered +5V</td> </tr> <tr> <td>2</td> <td>USB_0_N</td> <td>Port 0 Data</td> </tr> <tr> <td>3</td> <td>USB_0_P</td> <td>Port 0 Data</td> </tr> <tr> <td>4</td> <td>USB_GND_0</td> <td>Port 0 Filtered Digital Ground</td> </tr> <tr> <td>5</td> <td>USB_GND_1</td> <td>Port 1 Filtered Digital Ground</td> </tr> <tr> <td>6</td> <td>USB_1_N</td> <td>Port 1 Data</td> </tr> <tr> <td>7</td> <td>USB_1_P</td> <td>Port 1 Data</td> </tr> <tr> <td>8</td> <td>VCC_USB_1</td> <td>Port 1 Filtered +5V</td> </tr> </tbody> </table>			Pin	Signal	Description	1	VCC_USB_0	Port 0 Filtered +5V	2	USB_0_N	Port 0 Data	3	USB_0_P	Port 0 Data	4	USB_GND_0	Port 0 Filtered Digital Ground	5	USB_GND_1	Port 1 Filtered Digital Ground	6	USB_1_N	Port 1 Data	7	USB_1_P	Port 1 Data	8	VCC_USB_1	Port 1 Filtered +5V
	Pin	Signal	Description																											
	1	VCC_USB_0	Port 0 Filtered +5V																											
	2	USB_0_N	Port 0 Data																											
	3	USB_0_P	Port 0 Data																											
	4	USB_GND_0	Port 0 Filtered Digital Ground																											
	5	USB_GND_1	Port 1 Filtered Digital Ground																											
	6	USB_1_N	Port 1 Data																											
	7	USB_1_P	Port 1 Data																											
8	VCC_USB_1	Port 1 Filtered +5V																												
																														

SATA

Description

The Xtreme/SBC PCI-104 provides 2 SATA host connections.

US15W: Most Qseven modules based on the US15W, convert the US15W's IDE interface to one SATA connection (as IDE master) and one built-in NAND based flash drive (as IDE slave). Consult the Qseven module's documentation for more information.

In this case only P10A connector is active

Connector & LEDs

Function	SATA host																	
Locations	P10A, P10B																	
Type	Industry standard right angle sata host connector Molex 0470804005 (or equivalent)																	
Pinout	<table border="1"> <thead> <tr> <th>Pin</th> <th>Signal</th> </tr> </thead> <tbody> <tr> <td>1</td> <td>GND</td> </tr> <tr> <td>2</td> <td>SATA_TX_P</td> </tr> <tr> <td>3</td> <td>SATA_TX_N</td> </tr> <tr> <td>4</td> <td>GND</td> </tr> <tr> <td>5</td> <td>SATA_RX_N</td> </tr> <tr> <td>6</td> <td>SATA_RX_P</td> </tr> <tr> <td>7</td> <td>GND</td> </tr> </tbody> </table>			Pin	Signal	1	GND	2	SATA_TX_P	3	SATA_TX_N	4	GND	5	SATA_RX_N	6	SATA_RX_P	7
Pin	Signal																	
1	GND																	
2	SATA_TX_P																	
3	SATA_TX_N																	
4	GND																	
5	SATA_RX_N																	
6	SATA_RX_P																	
7	GND																	

Function	SATA Status LEDs					
Locations	<table border="1"> <thead> <tr> <th>Pin</th> <th>Signal</th> </tr> </thead> <tbody> <tr> <td>D13</td> <td>Activity</td> </tr> </tbody> </table>	Pin		Signal	D13	Activity
Pin	Signal					
D13	Activity					

PCI-104

Description

The Xtreme/SBC PCI-104 allows up to 4 PCI-104 add-on boards to be installed in a “stack up” configuration. The PCI-104 connected through a PCIe to PCI bridge which is attached the first x1 PCIe lane of the Qseven connector.

Note: The Xtreme/SBC PCI-104 provides 3.3V generated from the +5V input power. The entire +3.3V rail on the PCI-104 stack is limited to 4A.

Connectors

Function	PCI-104 (Top Stacking Only)				
Locations	P2				
Type	Industry standard EPT 264-60303-02				
Pinout	 <p>(A1 @ Bottom Left Corner)</p>				
	Pin	A	B	C	D
	1	GND	Reserved	+5	AD00
	2	VI/O	AD02	AD01	+5V
	3	AD05	GND	AD04	AD03
	4	C/BE0#	AD07	GND	AD06
	5	GND	AD09	AD08	GND
	6	AD11	VI/O	AD10	M66EN
	7	AD14	AD13	GND	AD12
	8	+3.3V	C/BE1#	AD15	+3.3V
	9	SERR#	GND	Reserved	PAR
	10	GND	PERR#	+3.3V	Reserved
	11	STOP#	+3.3V	LOCK#	GND
	12	+3.3V	TRDY#	GND	DEVSEL#
	13	FRAME#	GND	IRDY#	+3.3V
	14	GND	AD16	+3.3V	C/BE2#
	15	AD18	+3.3V	AD17	GND
	16	AD21	AD20	GND	AD19
	17	+3.3V	AD23	AD22	+3.3V
	18	IDSEL0	GND	IDSEL1	IDSEL2
	19	AD24	C/BE3#	VI/O	IDSEL3
	20	GND	AD26	AD25	GND
	21	AD29	+5V	AD28	AD27
	22	+5V	AD30	GND	AD31
	23	REQ0#	GND	REQ1#	VI/O
	24	GND	REQ2#	+5V	GNT0#
	25	GNT1#	VI/O	GNT2#	GND
	26	+5V	CLK0	GND	CLK1
	27	CLK2	+5V	CLK3	GND
	28	GND	INTD#	+5V	RST#
	29	+12V	INTA#	INTB#	INTC#
	30	-12V	REQ3#	GNT3#	GND

LPC Super I/O

The Xtreme/SBC PCI-104 implements many low speed legacy I/O features with the SMSC SCH3114 Super I/O, which is connected to the Qseven module via the LPC (Low Pin Count) bus. This Super I/O device provides 4 serial ports, 2 PS/2, and many other status / control features.

Note: the Qseven specification states that all Qseven modules BIOS implementations must support either the Winbond W83627 or SMSC SCH3114.

Serial

Description

Two RS232 serial ports are provided on P9 and two RS485 serial ports are provided on P11.

For the RS485 ports, the default configuration is full duplex without any bias or termination. Various resistors configurations can be populated to enabled TX and RX termination as well as RTS control. The following diagram shows the available configuration options. Contact Connect Tech's support department for further information.

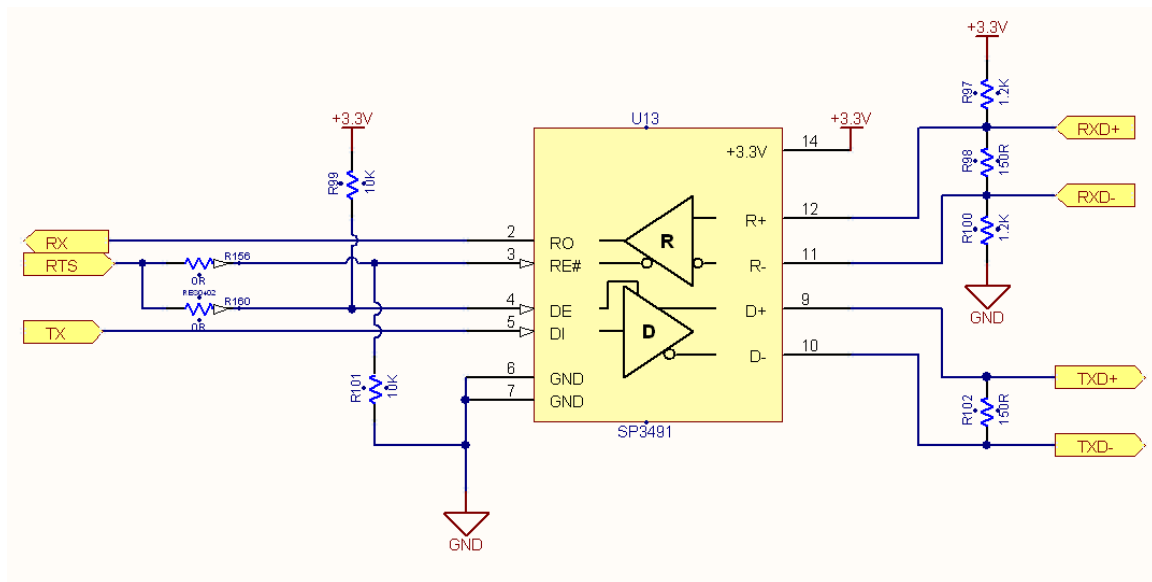

Resistor	Function	Default
R99	Always enable driver	Populated
R101	Always enable receiver	Populated
R156	RTS controlled receiver	
R160	RTS controlled driver	
R98	Receiver termination	
R102	Driver termination	
R100	Receiver bias	
R97	Receiver bias	

Connectors

Function	RS232 x2			
Locations	P9			
Type	2x10 2mm header			
Pinout	Pin	Signal	Pin	Signal
	1	DCD1	2	DSR1
	3	RXD1	4	RTS1
	5	TXD1	6	CTS1
	7	DTR1	8	RI1
	9	GND	10	N/C
	11	DCD2	12	DSR2
	13	RXD2	14	RTS2
	15	TXD2	16	CTS2
	17	DTR2	18	RI2
	19	GND	20	N/C



Function	RS485 x2			
Locations	P11			
Type	2x10 2mm header			
Pinout	Pin	Signal	Pin	Signal
	1	RXD0+	2	N/C
	3	TXD0+	4	N/C
	5	TXD0-	6	N/C
	7	RXD0-	8	N/C
	9	GND	10	N/C
	11	RXD1+	12	N/C
	13	TXD1+	14	N/C
	15	TXD1-	16	N/C
	17	TXD1-	18	N/C
	19	GND	20	N/C





PS/2 Keyboard and Mouse

Description

A PS/2 keyboard and PS/2 mouse interface are provided via P13; where the PS/2 voltage is selectable with J1. Refer to the specification printed on the bottom of the keyboard and mouse to determine which voltage to select; in most cases this is 5V.

Connectors & Jumpers

Function	PS/2 Keyboard and Mouse			
Locations	P13			
Type	Molex 0532610671 connector			
Pinout	Pin	Signal	Description	
	1	KDAT	Keyboard Data	
	2	KCLK	Keyboard Clock	
	3	PS2_GND	Filtered digital ground	
	4	PS2_VCC	Filtered PS/2 supply voltage, via J1	
	5	MDAT	Mouse Data	
	6	MCLK	Mouse Clock	

Function	PS/2 voltage select Selects either +3.3Vauxiliary or +5V auxiliary.		
Location	J1		
Type	1x3 0.1" jumper		
Pinout	Position	Description	
	1-2	+3.3V_A	
	2-3	+5V_A	
	off	floating	
Default	+3.3V		

Power

Description

The Xtreme/SBC PCI-104 is designed to be powered from an ATX type power supply, and support many of the ACPI features like suspend to RAM. A CR1225 battery holder (P16) provides the VBAT for the Qseven module.

The Xtreme/SBC PCI-104 generates 3.3V on board, to facilitate alternate powering options.

WARNING: If using a PCI-104 power supply that supplies voltages to the Xtreme/SBC PCI-104 through the PCI-104 connector, you must ensure this power supply DOES NOT supply +3.3V (as this would conflict with the onboard +3.3V).

Other powering options include

A) +5V & +12V only: The ATX features can be bypassed by powering +5V_SB with same 5 volt supply as the +5V input pins.

B) +5V only: similar to the above cause, but excluding the +12V which is used only by the backlight and PCI-104 connector. Before attempting this, verify that this configuration is appropriate for the target installation.

Connectors & Jumpers

Function	ATX input power		
Location	P6		
Type	JST B15B-EH-A		
Pinout	Pin	Signal	Description
	1	+5V	+5V input, powers onboard power regulators & Qseven module
	2	GND	Digital Ground
	3	+5V	+5V input, powers onboard power regulators & Qseven module
	4	GND	Digital Ground
	5	+5V	+5V input, powers onboard power regulators & Qseven module
	6	+5V_SB	+5V standby input, powers +3.3V auxiliary power
	7	GND	Digital Ground
	8	PSON#	Power Supply On
	9	PWROK	Power OK
	10	+3.3V	+3.3V input, not used by Xtreme/SBC PCI-104. +3.3V is derived on internally
	11	GND	Digital Ground
	12	+12V	+12V input, used by PCI-104 and backlight
	13	+12V	+12V input, used by PCI-104 and backlight
	14	GND	Digital Ground
15	-12V	-12V input, not used	



Function	Suspend Selection Selects either S3 or S5.									
Location	J7									
Type	1x3 2 mm									
Pinout	<table border="1"> <thead> <tr> <th>Position</th> <th>Description</th> </tr> </thead> <tbody> <tr> <td>1-2</td> <td>Suspend S3</td> </tr> <tr> <td>2-3</td> <td>Suspend S5</td> </tr> <tr> <td>off</td> <td>Floating</td> </tr> </tbody> </table>		Position	Description	1-2	Suspend S3	2-3	Suspend S5	off	Floating
Position	Description									
1-2	Suspend S3									
2-3	Suspend S5									
off	Floating									
Default	S3									

Function	Power Supply on Selects either PS_ON# signal from Qseven module or always on									
Location	J8									
Type	1x3 2mm									
Pinout	<table border="1"> <thead> <tr> <th>Position</th> <th>Description</th> </tr> </thead> <tbody> <tr> <td>1-2</td> <td>Always on</td> </tr> <tr> <td>2-3</td> <td>Qseven PS_ON#</td> </tr> <tr> <td>off</td> <td>floating</td> </tr> </tbody> </table>		Position	Description	1-2	Always on	2-3	Qseven PS_ON#	off	floating
Position	Description									
1-2	Always on									
2-3	Qseven PS_ON#									
off	floating									
Default	Qseven PS_ON#									

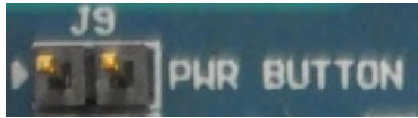
Function	Power Button Selects either +3.3Vauxiliary or +5V auxiliary.						
Location	J9						
Type	1x2 2mm header						
Pinout	<table border="1"> <thead> <tr> <th>Position</th> <th>Description</th> </tr> </thead> <tbody> <tr> <td>1</td> <td>PWR_BTN#</td> </tr> <tr> <td>2</td> <td>Ground</td> </tr> </tbody> </table>		Position	Description	1	PWR_BTN#	2
Position	Description						
1	PWR_BTN#						
2	Ground						

Fan Control

Description

If actively cooling is required; P14 can be used to power and control a fan with J2 selecting the fan voltage.

Connectors & Jumpers

Function	Fan power/control													
Location	P14													
Type	JST B15B-EH-A connector													
Pinout	<table border="1"> <thead> <tr> <th>Pin</th> <th>Signal</th> <th>Description</th> </tr> </thead> <tbody> <tr> <td>1</td> <td>FAN_SPEED</td> <td>Speed signal</td> </tr> <tr> <td>2</td> <td>FAN_PWR</td> <td>Fan power selected by J2</td> </tr> <tr> <td>3</td> <td>FAN_GND</td> <td>Filtered digital ground</td> </tr> </tbody> </table>			Pin	Signal	Description	1	FAN_SPEED	Speed signal	2	FAN_PWR	Fan power selected by J2	3	FAN_GND
Pin	Signal	Description												
1	FAN_SPEED	Speed signal												
2	FAN_PWR	Fan power selected by J2												
3	FAN_GND	Filtered digital ground												

Function	Fan power Selection Selects either +5V or +12V.									
Location	J2									
Type	1x3 0.100" jumper									
Pinout	<table border="1"> <thead> <tr> <th>Position</th> <th>Description</th> </tr> </thead> <tbody> <tr> <td>1-2</td> <td>+12V</td> </tr> <tr> <td>2-3</td> <td>+5V</td> </tr> <tr> <td>off</td> <td>Floating</td> </tr> </tbody> </table>			Position	Description	1-2	+12V	2-3	+5V	off
Position	Description									
1-2	+12V									
2-3	+5V									
off	Floating									
Default	floating									

Function	Fan PWM polarity Selects either positive or negative							
Location	J3							
Type	1x2 2mm jumper							
Pinout	<table border="1"> <thead> <tr> <th>Position</th> <th>Description</th> </tr> </thead> <tbody> <tr> <td>off</td> <td>Positive</td> </tr> <tr> <td>on</td> <td>Negative</td> </tr> </tbody> </table>			Position	Description	off	Positive	on
Position	Description							
off	Positive							
on	Negative							
Default	floating							

Battery

Description

A CR1225 battery holder is provided at P16. This is a standard 3V battery, which powers the RTC (real time clock) on the CPU module. In most cases, it is not required to preserve critical BIOS settings as most Qseven modules have a flash based BIOS.

Connector & LEDs

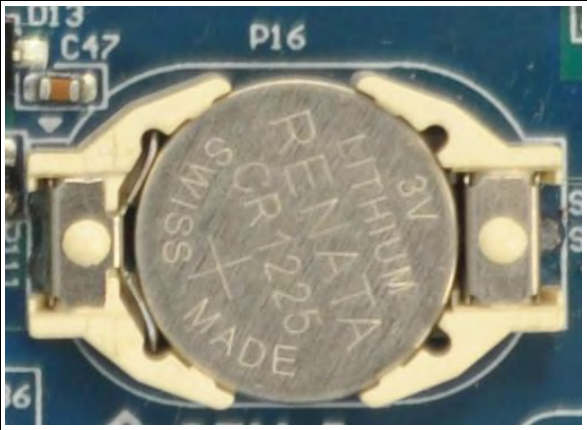
Function	Battery	
Location	P16	
Type	CR1225 battery holder	

Hardware Installation

1. Ensure all external system power supplies are off.
2. Install the Qseven module into P1. Be sure to follow the manufacturer's direction for proper heatsink/heatspreader installation.
3. Verify all jumper settings from the relevant sections, paying special attention the power selection jumpers

Jumper	Function	Selection	Position
J1	PS/2 power	+5V	2-3
J2	Fan Power	+12V	1-2
J3	Fan PWM polarity	Positive	Off
J4	LVDS panel power	+3.3V	2-3
J5	LVDS backlight enable polarity	positive	Off
J6	LVDS Backlight Power	+12V	1-2
J7	Suspend Selection	S3	1-2
J8	Power Supply On	From Qseven module	2-3

4. Install the necessary cables for the application. At a minimum, this would include:
 - a) Power cable, either ATX or +5V/+12V only
 - b) Display cable, either VGA or LVDS
 - c) Keyboard, either PS/2 or USB
 - d) Power button, if applicable

For the relevant cables, see the Cables & Interconnect section of this manual

5. Stack any necessary PCI-104 modules on top of the Xtreme/SBC PCI-104 via P2, with the appropriate mounting hardware
6. Connect the appropriate I/O peripherals to the interface cables: keyboard, mouse, Ethernet, monitor, etc.
7. Connect the power cable to power supply
8. Turn on the supply.

Software Installation & Configuration

In general, always refer to the Qseven module's manual for proper installation of drivers and configuration software; as well as for appropriate BIOS settings.

The following sections provides some specific notes and hints for successful module integration

Operating System Notes

Linux

General

PS/2: Add kernel option `i8042.nopnp` to ensure keyboard and mouse PS/2 keyboard and mouse operation

Power down: Add kernel option `acpi=force` to ensure proper software shutdown.

US15W Specific

Graphics: Intel Driver support for the Poulsbo / GMA500) is limited to several distributions (Redhat, Fedora). See IEGD (Intel Embedded Graphics Driver) website for details

<http://edc.intel.com/Software/Downloads/IEGD/#compatibility>

Other distributions, such as Linux, are supported through the open source community.

Windows

General

Ethernet:

Install the appropriate Ethernet driver from the Qseven module vendor's website.

US15W Specific

Graphics:

In some cases, the secondary LVDS display will appear washed out, to avoid this ensure the correct version of the IEGD is installed.

Cables & Interconnect

The following table summarizes the Xtreme/SBC PCI-104's headers and lists the matching cables included with the optional cable kit CKG001.

Location	PCB Connector	Cable Part Number	Drawing Number	Description	PCB End	Interface End
P3A, P3B	Hirose DF13-8P-1.25H(50)	CBG071	CTIC-00182	USB (dual)	Hirose DF13A-8S-1.25C	USB 2.0 Type A female
P4	MLE TSHSM-205-D-06-G-V-L	CBG065	CTIC-00181	GBE	2x5 2mm socket	RJ45 socket, GBE Ethernet
P5	MLE TSHSM-205-D-06-G-V-L	CBG070	CTIC-00180	VGA	2x5 2mm socket	VGA HD15 Female
P6	JST B15B-EH-A(LF)(SN)	CBG074	CTIC-00184	ATX power	JST EHR-15	ATX 20 pin male
P6	JST B15B-EH-A(LF)(SN)	CBG075	CTIC-00185	5V / 12V only power	JST EHR-15	Molex disk drive power male
P7	Hirose DF14-30P-1.25H(25)	CBG076	CTIC-00196	LVDS un-terminated	Hirose DF14-30S-1.25C	N/A
P8	Hirose DF13-8P-1.25H(50)	CBG078	CTIC-00198	Backlight un-terminated	Hirose DF13A-8S-1.25C	N/A
P9, P11	MLE TSHSM-210-D-06-G-V-L	CBG073	CTIC-00183	Serial (dual)	2x10 2mm socket	2 X DB-9 Male
P10A, P10B	Molex 470804005	CBG079	CTIC-00199	SATA	SATA	SATA
P13	Molex 532610671	CBG072	CTIC-00186	Keyboard and Mouse	Molex 51021-0600	2 X 6 Mini-Din
J9	Samtec TMM-102-02-L-S	CBG080	CTIC-00200	Power Button	1x2 2mm socket	Momentary Pushbutton
P14	Hirose DF13-3P-1.25H(20)	CBG081	CTIC-00201	Fan Power	Hirose DF13A-3S-1.25C	N/A

Cable drawings are available upon request (support@connecttech.com)

Dimensions

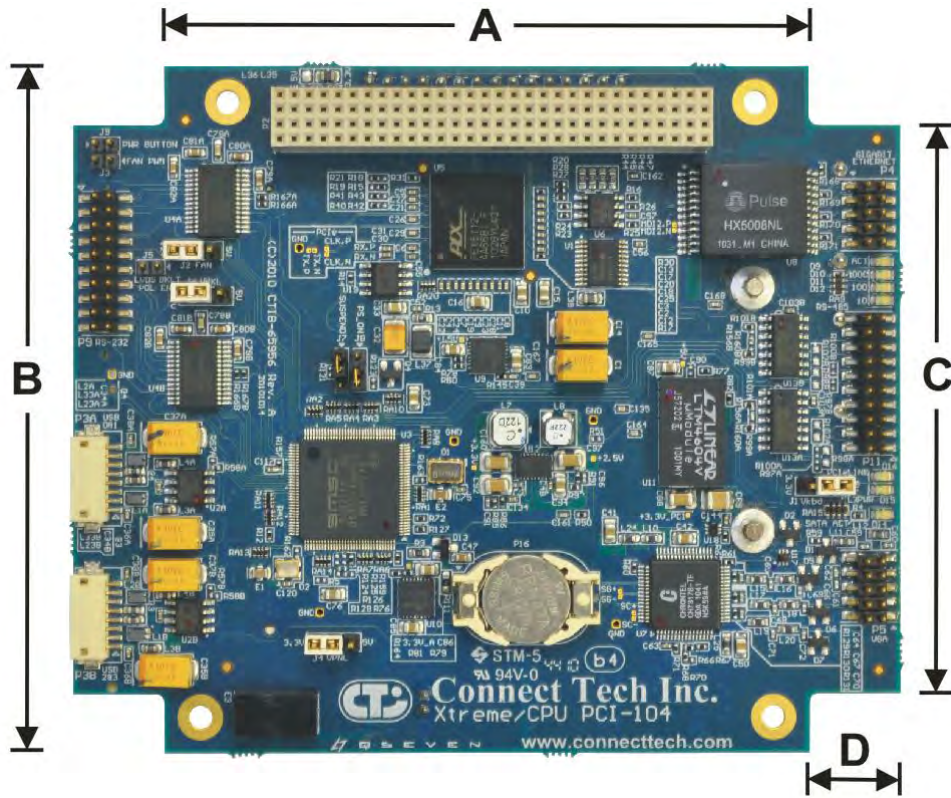

Dimension	Value
A	3.550" / 90.170mm
B	3.775" / 95.885mm
C	3.125" / 79.375mm
D	0.500" / 12.700mm
Full 3D Dimensions	Download 3D STEP Model File Here

Specifications

Form Factor	PCI-104, (Support up to 4 installed PCI-104 add-on boards)
Display	VGA, LVDS flat panel
Storage	2x SATA (7 pin connector)
Serial Interface	2x RS-232, 2x RS-485
USB	4x USB 2.0
Ethernet	1x Gigabit Ethernet
Dimensions	PC/104 compliant
Temperature	-20°C to 70°C (-4°F to 158°F) ^[1]
Power	ATX supply input
Power Consumption	850 mA @ 5V Qseven carrier circuitry only. Does not include module power.
Additional I/O	PS/2 keyboard and mouse
Warranty and Support	Lifetime warranty and free technical support

[1] Temperature range is limited by the SDVO to VGA conversion circuitry.