



Connect Tech Inc.
Industrial Strength Communications



Xtreme/104 Isolated *12 Port, Electrically Isolated Serial Communications Adapter*

User's Manual

Connect Tech Inc
42 Arrow Road
Guelph, Ontario
N1K 1S6
Tel: 519-836-1291
800-426-8979
Fax: 519-836-4878
Email: sales@connecttech.com
support@connecttech.com
Web: www.connecttech.com

CTIM-00025, Revision 1.02, November 2005

Limited Lifetime Warranty

Connect Tech Inc. provides a Lifetime Warranty for all Connect Tech Inc. products. Should this product, in Connect Tech Inc.'s opinion, fail to be in good working order during the warranty period, Connect Tech Inc. will, at its option, repair or replace this product at no charge, provided that the product has not been subjected to abuse, misuse, accident, disaster or non Connect Tech Inc. authorized modification or repair.

You may obtain warranty service by delivering this product to an authorized Connect Tech Inc. business partner or to Connect Tech Inc. along with proof of purchase. Product returned to Connect Tech Inc. must be pre-authorized by Connect Tech Inc. With an RMA (Return Material Authorization) number marked on the outside of the package and sent prepaid, insured and packaged for safe shipment. Connect Tech Inc. will return this product by prepaid ground shipment service.

The Connect Tech Inc. Lifetime Warranty is defined as the serviceable life of the product. This is defined as the period during which all components are available. Should the product prove to be irreparable, Connect Tech Inc. reserves the right to substitute an equivalent product if available or to retract Life Time Warranty if no replacement is available.

The above warranty is the only warranty authorized by Connect Tech Inc. Under no circumstances will Connect Tech Inc. be liable in any way for any damages, including any lost profits, lost savings or other incidental or consequential damages arising out of the use of, or inability to use, such product.

The latest manuals, installation guides and drivers are located on the Connect Tech website. Please visit the download zone for more information:

<http://www.connecttech.com/asp/Support/DownloadZone.asp>

If you have any questions, please contact Connect Tech Customer Support.

Email: support@connecttech.com

Phone: 1-800-426-8979 (within North America)

Outside North America: 1-519-836-1291

Fax: 1-519-836-4878

Copyright Notice

The information contained in this document is subject to change without notice. Connect Tech shall not be liable for errors contained herein or for incidental consequential damages in connection with the furnishing, performance, or use of this material. This document contains proprietary information that is protected by copyright. All rights are reserved. No part of this document may be photocopied, reproduced, or translated to another language without the prior written consent of Connect Tech, Inc.

Copyright © 2005 by Connect Tech, Inc.

Trademark Acknowledgment

Connect Tech, Inc. acknowledges all trademarks, registered trademarks and/or copyrights referred to in this document as the property of their respective owners.

Not listing all possible trademarks or copyright acknowledgments does not constitute a lack of acknowledgment to the rightful owners of the trademarks and copyrights mentioned in this document.

Table of Contents

Limited Lifetime Warranty ii
 Copyright Notice..... ii
 Trademark Acknowledgment..... ii
 Table of Contents iii
 Figures iii
 Tables..... iii
 Product Overview 1
 Electrical Isolation 1
 Hardware Installation..... 3
 Port Addresses 3
 Status Port Addresses 3
 Custom Port Addresses..... 3
 Interrupt Selection 5
 Baud Rate Selection 5
 Software Installation 6
 Specifications..... 6
 Operating Environment 6
 Power Requirements..... 6
 PC Bus Interface..... 6
 Communications..... 6
 UARTs..... 6
 RS-232..... 7
 RS-422/485..... 7
 Control Signals..... 7
 Electrical Isolation..... 7
 Dimensions..... 7
 Xtreme/104 Isolated Main PCB..... 7
 Daughter Board 7
 Connectors/Interface..... 7
 RS-232/422/485 ports..... 7
 RS-232 ports..... 7
 Cabling 7
 Connectors/Pinouts..... 8
 RS-232/RS-422/485 Interfaces 9
 Electrical Interface Selection..... 9
 Full Duplex Mode (four wire) 9
 Half Duplex RS-422/485 (two wire) 9
 Multi-drop Mode (four wire)..... 9
 Line Bias and Termination 9

Figures

Figure 1: Xtreme/104 Isolated 12 port serial adapter 2
 Figure 2: Port Control, Group A (ports 1 to 4)..... 4
 Figure 3: Port Control, Group B (ports 5 to 8) 4
 Figure 4: Jumpers JG12, JG13 and JG14 4
 Figure 5: Address and IRQ Setup, JG3 5
 Figure 6: IRQ Selection, JG1 and JG2 5
 Figure 7: Pinouts 8
 Figure 8: Common Jumper Configurations, Example 1 11
 Figure 9: Common Jumper Configurations, Example 2 12

Tables

Table 1: Port Address Settings 3

Product Overview

The Xtreme/104 Isolated adapters are high density, high performance, 12 port serial adapters that fully comply with PC/104 form factor specifications.

Your Xtreme/104 Isolated product consists of the following components:

- Xtreme/104 electrically isolated adapter
- Xtreme/104 Isolated Windows 98/Me, Windows CE/CE .NET, XP/XP Embedded, Windows 2000 and QNX 4.X device drivers.

Xtreme/104 Isolated adapters include unique features such as:

- Twelve asynchronous I/O ports
 - Eight selectable RS-232/422/485 ports
 - Four dedicated RS-232 ports
- Support for all three RS-422/485 modes
 - Full duplex (four wire)
 - Half duplex (two wire, with automatic data direction control)
 - Multi-drop (four wire)
- Electrical isolation on each port using Analog Device's *iCoupler*® technology, providing up to 1 kV AC peak to peak of protection
- Each port is electrically isolated from one another
- Data communication speeds up to 460.8 Kbps (RS-422/485) and 115.2 Kbps (RS-232)
- 16C2850 dual UARTs control each port providing 128 bytes of TxD/RxD FIFO buffers
- Eight jumper selectable I/O address ranges
- Driver support for Linux, QNX, Solaris, SCO Unix, Windows 98/Me, Windows CE/CE .NET, Windows XP/XP Embedded and Windows NT/2000
- Space saving, 12-port design

Electrical Isolation

The Xtreme/104 Isolated uses electrical isolator technologies to provide 1.0 kV AC peak to peak isolation between each port and also between each port and your system. However there are some considerations to note:

1. Isolation can degrade if the board is subjected to high humidity, especially conditions that are right for condensation to occur.
2. Isolation can degrade if airborne dust is allowed to accumulate on the surface of the board.
3. **An electrical shock hazard could exist** depending on what equipment is connected to the Xtreme/104 Isolated. Under these circumstances the wiring and/or cabling leading to the serial port connections may have high voltages on them. You must use appropriately insulated cables in these situations.
4. Please contact your Connect Tech Technical Support Specialist for any questions related to the application of optical isolation.

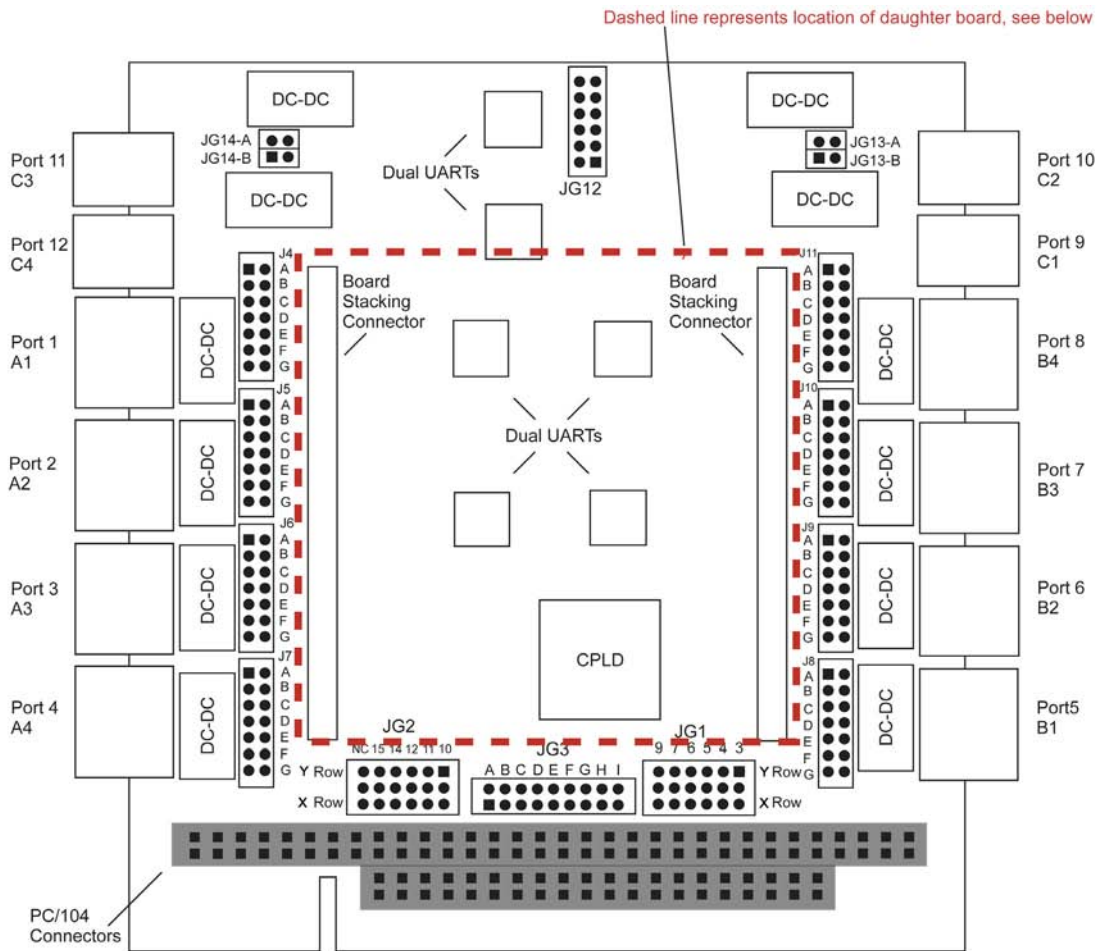

Dashed line represents location of daughter board, see below

(Daughter board not shown to scale.)

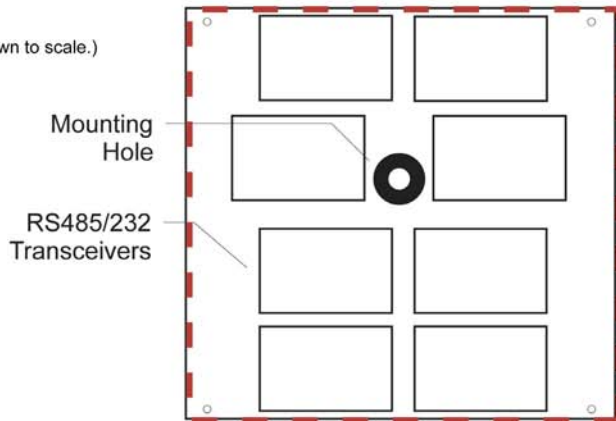

PLEASE NOTE:
If you are installing the daughter board, the mounting holes on the daughter board and the main board **MUST LINE UP** or you risk damaging the boards.

Figure 1: Xtreme/104 Isolated 12 port serial adapter

Hardware Installation

Port Addresses

Port addresses are configured with the jumper block JG3 on the Xtreme/104 Isolated adapter. Use jumpers A, B, and C to select a range of port addresses for the ports. Please refer to [Figure 5](#) for positions.

Status Port Addresses

Some operating system device drivers can utilize an Interrupt Status Port, for example, Linux. This will improve your Xtreme/104 Isolated's performance. The Xtreme/104 Isolated offers a status port and this port is enabled and disabled using jumper D on jumper block JG3.

Please refer to [Table 1](#) for a list of supported status port addresses.

Technical Tip:
Please make certain that the Status Port Enable jumper is disabled if your application is not using the Status Port. This eliminates the possibility of an address conflict with another device in your system.

Custom Port Addresses

If you require specific port addresses not listed in [Table 1](#) please contact Connect Tech Technical Support for further information.

Table 1: Port Address Settings

Setting #	Jumper JG3			Port Group	Port addresses in hex				Status Port Address Enabled with JG3-D (In=enabled)
	A	B	C		1	2	3	4	
0	IN	IN	IN	A	150	158	160	168	190
				B	250	258	260	268	290
				C	1A0	1A8	1B0	1B8	1E0
1	OUT	IN	IN	A	250	258	260	268	290
				B	1A0	1A8	1B0	1B8	1E0
				C	2A0	2A8	2B0	2B8	2E0
2	IN	OUT	IN	A	1A0	1A8	1B0	1B8	1E0
				B	2A0	2A8	2B0	2B8	2E0
				C	100	108	110	118	140
3	OUT	OUT	IN	A	2A0	2A8	2B0	2B8	2E0
				B	100	108	110	118	140
				C	200	208	210	218	240
4	IN	IN	OUT	A	100	108	110	118	140
				B	200	208	210	218	240
				C	380	388	390	398	3C0
5	OUT	IN	OUT	A	200	208	210	218	240
				B	380	388	390	398	3C0
				C	300	308	310	318	340
6	IN	OUT	OUT	A	380	388	390	398	3C0
				B	300	308	310	318	340
				C	150	158	160	168	190
7	OUT	OUT	OUT	A	300	308	310	318	340
				B	150	158	160	168	190
				C	250	258	260	268	290

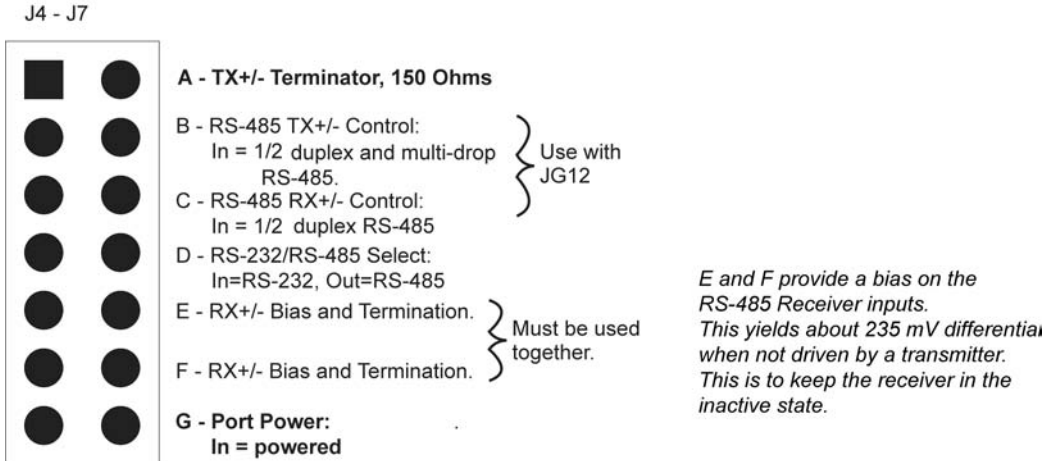

Figure 2: Port Control, Group A (ports 1 to 4)

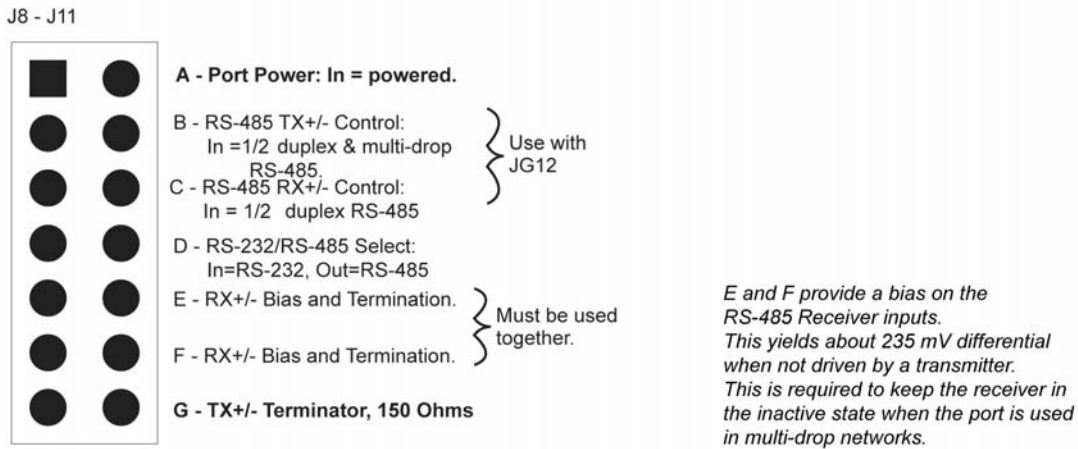

Figure 3: Port Control, Group B (ports 5 to 8)

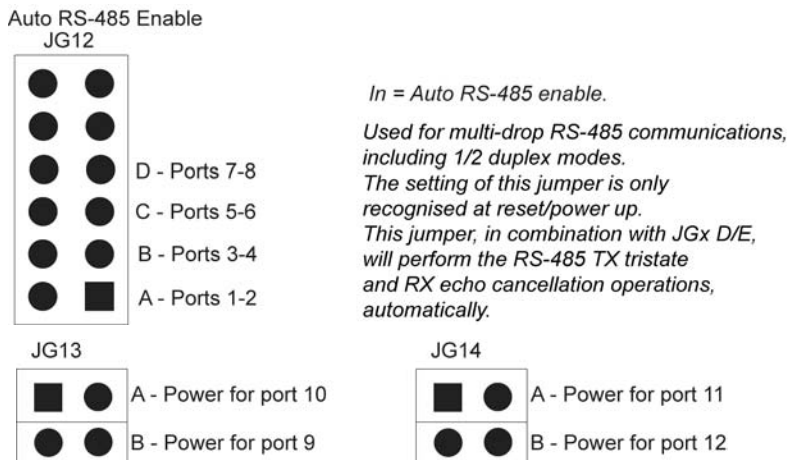

Figure 4: Jumpers JG12, JG13 and JG14

Interrupt Selection

You can configure the interrupt request lines (IRQ) with the jumper blocks JG1 and JG2 on the Xtreme/104 Isolated adapter. (Please refer to [Figure 6](#).) You can configure the board to use three, four, five or six interrupts; or configure all ports to share one interrupt.

Baud Rate Selection

The Xtreme/104 Isolated is capable of baud rates up to 460.8 Kbps (4X oscillator) or 115.2 Kbps (1X oscillator) depending on whether a jumper block is installed across position JG3-E. (Please refer to [Figure 5](#).)

Custom baud rates are also available. Contact Connect Tech Inc. for further details about our Custom Product Program.

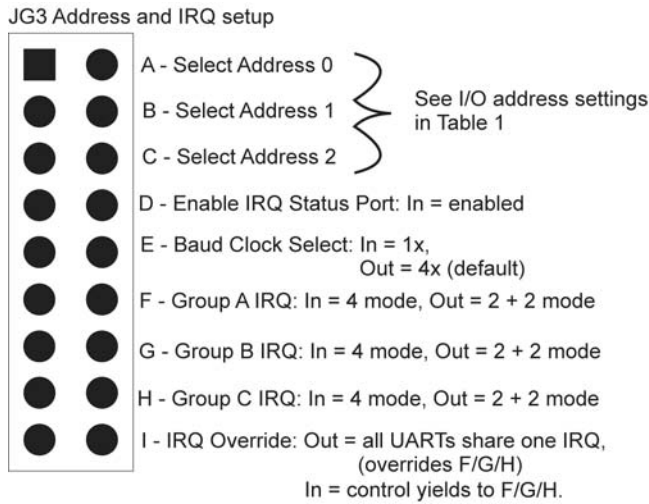

Figure 5: Address and IRQ Setup, JG3

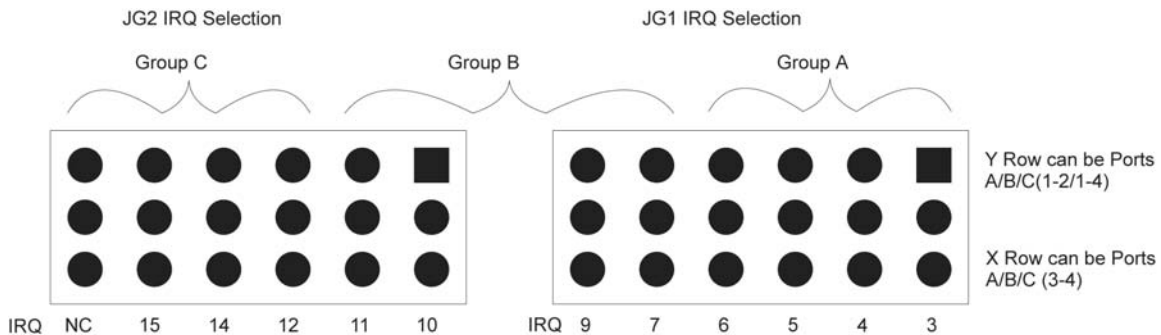

Figure 6: IRQ Selection, JG1 and JG2

Software Installation

Xtreme/104 Isolated adapters are standard multi-port serial adapters that utilize 16C2850 UARTs. In many cases, users have software that will interface directly to the Xtreme/104 Isolated adapters. Many operating systems come with a driver to control access to multiple 8250 style UARTs. Xtreme/104 Isolated adapters currently have device drivers for the following operating systems:

- Linux
- QNX
- SCO Unix/Openserver
- Windows 2000
- Windows 98/Me
- Windows CE
- Windows CE .NET
- Windows NT
- Windows XP
- Windows XP Embedded

The latest manuals, installation guides and drivers are located on the Connect Tech website. Please visit the download zone for more information:

http://www.connecttech.com/asp/Support/Download_Zone.asp

If you have any questions, please contact Connect Tech Customer Support.

Email: support@connecttech.com

Phone: 1-800-426-8979 (within North America)

Outside North America: 1-519-836-1291

Fax: 1-519-836-4878

Specifications

Operating Environment

- Storage temperature: -40° C to 150° C
 -40° F to 302° F
- Operating temperature:
 - -40° C to 70° C
 - -40° F to 158° F
- Humidity: 0 to 90% relative humidity, non-condensing

Power Requirements

- +5 V DC 500mA (typical), 1A (max)

PC Bus Interface

- Base address for UARTs is jumper selectable. Each UART requires 8 I/O addresses, 96 I/O addresses required
- One PC/104 16-bit expansion connector

Communications

UARTs

- XR16C2850 dual UART communication controllers
- On chip 128 byte TxD and RxD FIFO buffers per port
- Automatic RTS/CTS (Hardware) flow control
- Automatic XON/XOFF (Software) flow control
- Compatible with 16550 style software drivers

RS-232

- Programmable baud rate generator - up to 115.2 Kbps on all dedicated RS-232 ports
- 230.4 Kbps on all switchable ports

RS-422/485

- Programmable baud rate generator - up to 460.8 Kbps on all RS-422/485 ports
- Full duplex (four wire)
- Half duplex (two wire)
- Multi-drop (four wire)
- Jumper selectable Automatic direction control for two-wire half duplex
- Jumper selectable RxD/TxD line/bias termination resistors

Control Signals

- RS-232 TxD; RxD; RTS; CTS, ISOGND
- RS-422/485 TxD±; RTS±; CTS±; RxD±, ISOGND

Electrical Isolation

- 1.0 kV AC peak to peak on every signal of every port

Dimensions

Xtreme/104 Isolated Main PCB

- Length: 10.10 cm (3.55 inches) – includes connectors
- Width: 9.60 cm (3.78 inches)

Daughter Board

- Length: 5.80 cm (2.27 inches)
- Width: 5.50 cm (2.18 inches)

Height is fully compliant with PC/104 Specification 2.3

Connectors/Interface

RS-232/422/485 ports

- Ten pin right angle 2mm connectors

RS-232 ports

- Six pin right angle 2mm connectors
- (Please refer to [Figure 7](#) for pinouts)

Cabling

- 304 mm DB-9 male cables

Connectors/Pinouts

Connect Tech recommends using the following mating connectors for your Xtreme/104 Isolated product:

- 10 pin: Hirose part number DF11-10DS-2C
DigiKey part number H2023-ND
- 6 pin: Hirose part number DF11-6DS-2C
DigiKey part number H2021-ND
- Crimping sockets: DF11-2428SCA

Individual wire assemblies for the DF11 series can be found in DigiKey's online catalogue at www.digikey.com

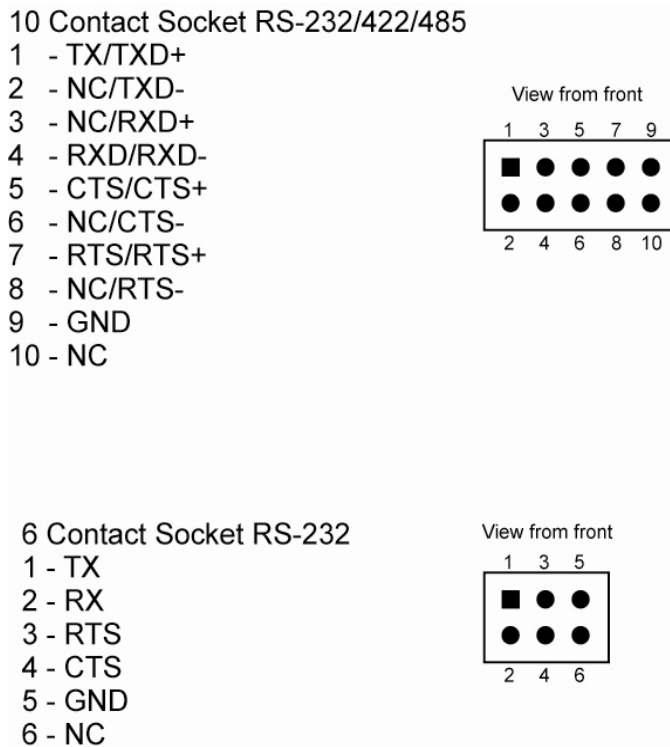

Figure 7: Pinouts

RS-232/RS-422/485 Interfaces

Electrical Interface Selection

The Xtreme/104 Isolated adapter provides jumper selectable RS-232 and RS-422/485 electrical interfaces on eight of its 12 ports.

Position D on jumper blocks J1 through J11 determines the individual electrical interfaces for the ports. Group “A” ports are controlled by jumper blocks J4 through J7: J4 for Port 1, J5 for Port 2, J6 for Port 3 and J7 for Port 4. Jumper blocks J8 through J11 determine the electrical interfaces for the “B” group of ports: J8 for Port 5, J9 for Port 6, J10 for Port 7 and J11 for Port 8. Jumpers installed across position D on any of these jumper blocks enable the RS-232 interface for that port; otherwise the RS-422/485 interface will apply. (Please refer to [Figure 9](#) for examples of various electrical interface selections.)

Full Duplex Mode (four wire)

By making sure that there are no jumpers on positions B and C of jumper blocks J4 to J11 you can run the individual RS-422/485 ports in full duplex mode. In this mode, TxD & RxD are active all the time. This mode is typically used in point to point situations much like RS-232. (Please refer to [Figure 2](#) and [Figure 3](#).)

Half Duplex RS-422/485 (two wire)

By jumpering positions B and C of jumper blocks J4 to J11, along with the corresponding position on JG12, you can run the individual RS-422/485 ports in half duplex mode. In this mode your Xtreme/104 Isolated adapter controls the transmitter and receiver circuits. RTS is turned on prior to and during transmission to enable the transmit driver and disable the receiver. RTS is turned off when not transmitting to disable the transmit driver (tri-stated) and enable the receiver. The Xtreme/104 Isolated adapter is responsible for timing the RTS toggle. (Please refer to [Figure 2](#) and [Figure 3](#).)

Multi-drop Mode (four wire)

Placing a jumper on position B of jumper blocks J4 to J11 and on the corresponding Auto-enable on JG12, allows you to run the individual RS-422/485 ports in multi-drop mode. In this mode the TxD line driver is enabled only when data is transmitted and RxD is enabled all the time. (Please refer to [Figure 2](#) and [Figure 3](#).)

Line Bias and Termination

The RS-422/485 ports of the Xtreme Isolated adapter feature jumper selectable line bias and termination resistors across RxD+/- and jumper selectable 150 Ohm termination resistors across TxD+/-.

Termination resistors are installed to improve the electrical performance of the RS-485 network. RS-485 networks are always wired in a daisy chain, from point-to-point-to-point and so on. Termination resistors are installed at the most extreme ends of that network; they can not be installed in the middle of the network. No more than two termination resistors can reside in the network. Termination resistors are useful in the following situations:

- Where long cabling 30m (100ft) or greater is used.
- Where the cable is of poor quality.
- When the application is using a high baud rate, 115.2 Kbps or greater.

For short point-to-point RS-485 networks, termination resistors are not usually required. While this may reduce power consumption of your adapter, be aware that you may risk poor or intermittent communications without the termination resistors.

To install a termination resistor across TxD+/- on your Xtreme Isolated adapter, install the appropriate jumper for a given serial port. (Please refer to [Figure 2](#) and [Figure 3](#).)

Bias and Termination resistors are applied across the RxD+/- pins. The bias resistors provide a valid differential voltage across the RxD+/- pins when there is no voltage applied across the RxD+/- input. The termination resistor has the same uses and the TxD+/- terminator as above.

The RxD+/- bias and termination resistors are used whenever your application requires the following:

- A terminator resistor across RxD+/-
- The Xtreme serial port is configured as the master in a 2-wire (Half Duplex) multi-drop network.

To install a bias and termination resistor across RxD+/- on your Xtreme/104 Isolated adapter install the appropriate jumpers, a total of two, for a given serial port. (Please refer to [Figure 2](#) and [Figure 3](#).)

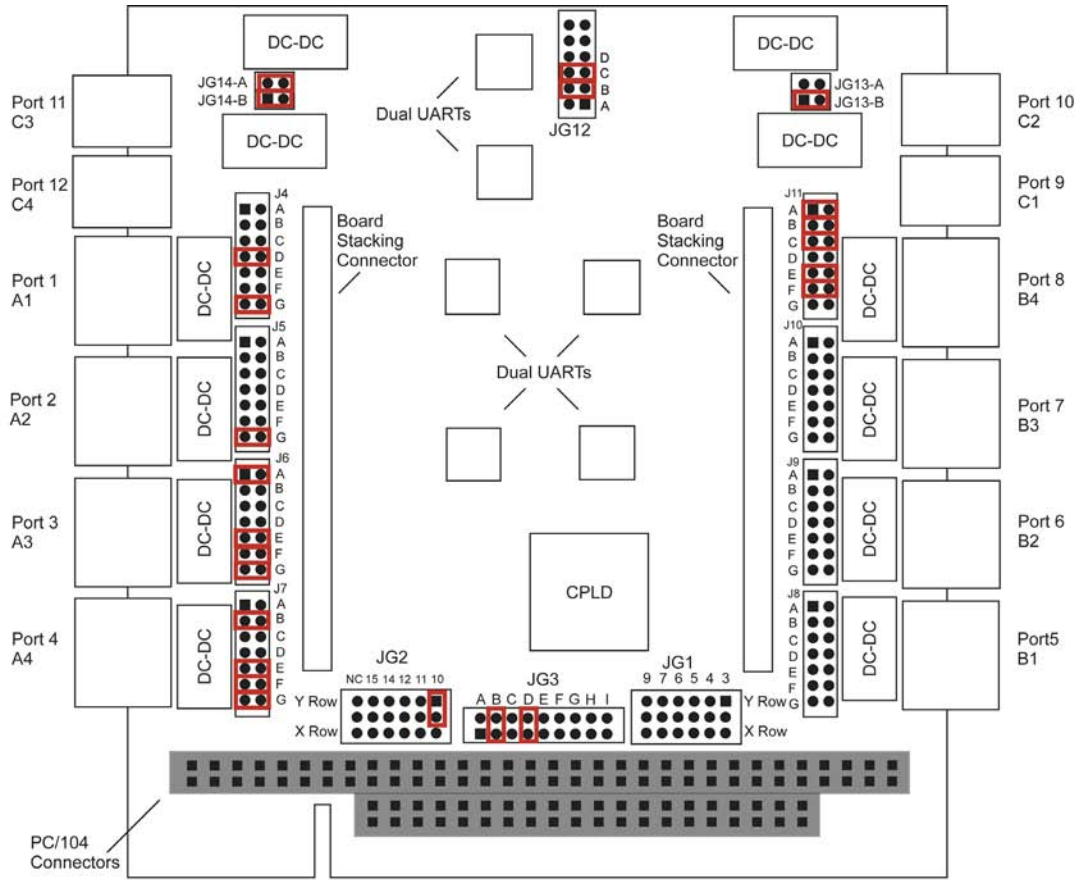

Port Settings

- Port 1 = RS-232
- Port 2 = RS-485 4-wire
- Port 3 = RS-485 4-wire TX terminator with RX Bias and Termination installed
- Port 4 = RS-485 4-wire multi-drop with RX Bias and Termination installed
- Port 5 = RS-485 2-wire multi-drop with RX Bias and Termination installed
- Port 6 = Not powered
- Port 7 = Not powered
- Port 8 = Not powered
- Port 9 = Fixed RS-232
- Port 10 = Not powered
- Port 11 = Fixed RS-232
- Port 12 = Fixed RS-232

I/O Addresses and Interrupts settings

- I/O Address Range = 5
- IRQ = 10, all ports share interrupt 5
- IRQ Status Ports enabled

Figure 8: Common Jumper Configurations, Example 1

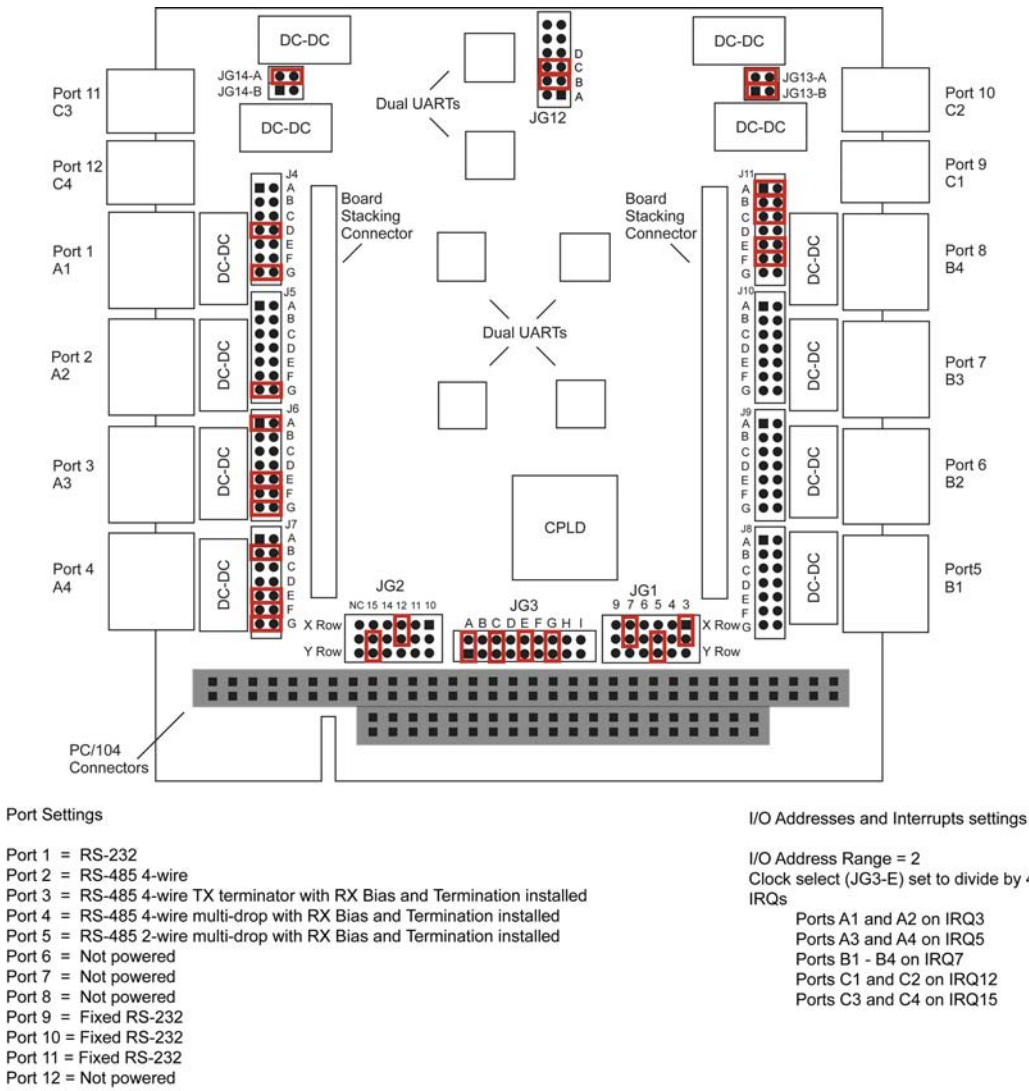

Figure 9: Common Jumper Configurations, Example 2