



**Connect Tech Inc.**  
*"Industrial Strength Communications"*

---

## **DFlex**

### **Multi-port Serial Communications Adapters**

### **User Manual**

**Connect Tech Inc**  
**42 Arrow Road**  
**Guelph, Ontario**  
**N1K 1S6**  
**Tel: 519 836-1291**  
**800-426-8979**  
**Fax: 519 836-4878**  
**Email: [sales@connecttech.com](mailto:sales@connecttech.com)**  
**URL: <http://www.connecttech.com>**

**CTIM-00098, Revision 1.13 May 31 2002**  
Part Number: MAN044



## LIMITED WARRANTY

Connect Tech Inc. warrants to the original purchaser of this Connect Tech hardware product that it is to be in good working order for a period of one year from the date of purchase from Connect Tech Inc. or an authorized Connect Tech dealer. Should this product, in Connect Tech Inc.'s opinion, fail to be in good working order during the warranty period, Connect Tech Inc. will, at its option, repair or replace this product at no charge, provided that the product has not been subjected to abuse, misuse, accident, disaster or non Connect Tech Inc. authorized modification or repair.

You may obtain Limited Warranty service by delivering this product to an authorized Connect Tech dealer or to Connect Tech Inc. along with proof of purchase. If this product is shipped, you agree to insure the product or assume risk of loss or damage in transit, and to prepay shipping charges to the warranty repair location.

The above warranty is the only warranty authorized by Connect Tech Inc. **UNDER NO CIRCUMSTANCES WILL CONNECT TECH INC. BE LIABLE IN ANY WAY FOR ANY DAMAGES, INCLUDING ANY LOST PROFITS, LOST SAVINGS OR OTHER INCIDENTAL OR CONSEQUENTIAL DAMAGES ARISING OUT OF THE USE OF, OR INABILITY TO USE, SUCH PRODUCT.**

## **Copyright Notice**

The information contained in this document is subject to change without notice. Connect Tech shall not be liable for errors contained herein or for incidental consequential damages in connection with the furnishing, performance, or use of this material. This document contains proprietary information which is protected by copyright. All rights are reserved. No part of this document may be photocopied, reproduced, or translated to another language without the prior written consent of Connect Tech, Inc.

Copyright © 1987, 1988, 1989, 1990, 1997, 2000, 2002 by Connect Tech, Inc.

## **Trademark Acknowledgment**

Connect Tech, Inc. acknowledges all trademarks, registered trademarks and/or copyrights referred to in this document as the property of their respective owners.

Not listing all possible trademarks or copyright acknowledgments does not constitute a lack of acknowledgment to the rightful owners of the trademarks and copyrights mentioned in this document.

## CLASS A COMPUTING DEVICE

**DFlex-2; DFlex-2/Fast**

**DFlex-4; DFlex-4/Fast**

**DFlex-8**

### FCC

This equipment complies with the requirements in Part 15 of FCC Rules for a Class A computing device. Operation of this equipment in a residential area may cause unacceptable interference to radio and TV reception requiring the operator to take whatever steps are necessary to correct the interference.

### DOC/IC

This Class A digital apparatus complies with Canadian ICES-003.

Cet appareil numérique de la classe A est conforme à la norme NMB-003 du Canada.



Connect Tech Inc. declares that the product(s) covered by the contents of this manual have been tested and found compliant with the below listed standards as required by the Electromagnetic Compatibility (EMC) Directive for General Immunity Compliance, EN 50 0082.1:1997

- EN 55022      Conducted and Radiated emissions
- EN 61000-4-2    Electrostatic Discharge
- EN 61000-4-3    Radiated Immunity
- EN 61000-4-4    Electrical Fast Transients

A handwritten signature in black ink, appearing to read 'Rod Doré'.

Rod Doré  
Manager of Engineering

A handwritten signature in black ink, appearing to read 'Dave Worthen'.

Dave Worthen, P.Eng.  
President

**General**

The above agency conformances were met by independent laboratory testing of Connect Tech Inc. product(s) with shielded cables, with metal hoods, attached to either the terminating connectors or cable assemblies supplied with the product(s).

**Failure to follow good EMC/EMI compliant cabling practices may produce more emissions or less immunity than were obtained in laboratory measurements.**

Operation of this equipment in a residential area may cause unacceptable interference to radio a TV reception, requiring the user to take whatever steps necessary to correct the interference.

## Table of Contents

### Chapter 1: Introduction

Introduction .....	1-1
Manual Overview .....	1-1
Conventions & Symbols .....	1-2
Product Overview .....	1-3
DFlex Adapter.....	1-4
DFlex Software .....	1-7
Customer Service Overview.....	1-7
RMA Overview .....	1-10

### Chapter 2: Hardware Installation


Introduction .....	2-1
Configuration.....	2-1
Port Addresses .....	2-2
Custom Port Addresses .....	2-3
Status Port Address .....	2-4
Custom Status Port Addresses .....	2-4
Interrupt Selection.....	2-5
Baud Rate Selection: DFlex/Fast.....	2-6
Serial Line Interface Modules (SLIM) .....	2-8
SLIM Installation .....	2-8
SLIM compatibility .....	2-11
Installing the DFlex Adapter in your System .....	2-11

### Chapter 3: Software Installation

Introduction .....	3-1
Configuration.....	3-1
DOS 3.XX - 6.XX.....	3-2
COMSET.EXE.....	3-2
DFLEX.SYS.....	3-3
CTIMODE.....	3-3
Accessing Ports.....	3-3
Character Device Access.....	3-4
INT 14h Access.....	3-4
Linux .....	3-7
Multiuser DOS 7 GOLD.....	3-8
Configuration .....	3-8
OS/2: DFlex-2/-2/Fast as COM3 & COM4.....	3-11
Configuration .....	3-12
QNX 2.XX .....	3-14
Configuration .....	3-14
QNX 4.XX .....	3-17
Configuration .....	3-17
QNX 6.XX .....	3-22

SCO Unix.....	3-23
Configuration .....	3-23
Other Configurations.....	3-29
Solaris .....	3-31
Windows 3.XX: DFlex-2/-2/Fast as COM3 & COM4....	3-32
Configuration .....	3-33
Windows 95 .....	3-35
DFlex Enhanced Driver .....	3-36
Installation .....	3-37
UART/FIFO Configuration.....	3-38
Configuration .....	3-39
Windows NT.....	3-43
DFlex Enhanced Driver .....	3-43
Configuration .....	3-44

## Chapter 4: Appendices

Appendix A: Specifications.....	4-1
Operating Environment .....	4-1
Power Requirements .....	4-1
PC Bus Interface .....	4-2
Communications .....	4-2
Control Signals .....	4-2
Dimensions .....	4-2
Connectors/Interface.....	4-2
Certification .....	4-3
FCC .....	4-3
DOC/IC .....	4-3
 .....	4-3
General .....	4-4
Appendix B: Connectors/Pinouts .....	4-5
Cable Connector Pinouts .....	4-5
Connector Box/Pinouts .....	4-9
SLIM Pinouts.....	4-11

**Chapter 4: Appendices (continued)**

Appendix C: Factory Settings ..... 4-13

    DFlex-2; DFlex-2/Fast ..... 4-13

        I/O Port Address Setting ..... 4-13

        IRQ Setting..... 4-14

    DFlex-4; DFlex-4/Fast ..... 4-15

        I/O Port Address Setting ..... 4-15

        IRQ Setting..... 4-16

    DFlex-8 ..... 4-17

        I/O Port Address Setting ..... 4-17

        IRQ Setting..... 4-18

Appendix D: SLIM Insertion/Removal ..... 4-19

    SLIM insertion ..... 4-19

    SLIM removal ..... 4-20

Appendix E: RS-232 Option ..... 4-21

    RS-232/Fast SLIM..... 4-23

    Installation ..... 4-23

Appendix F: RS-485/422 Option ..... 4-25

    RS-485/422 SLIM..... 4-26

    Installation ..... 4-28

    RS-485/422 Cable Wiring ..... 4-30

Appendix G: RS-423 Option..... 4-33

    Installation ..... 4-35

    RS-423 Cable Wiring..... 4-37

Appendix H: 20mA Current Loop Option ..... 4-39

    20mA Current Loop SLIM ..... 4-39

    Installation ..... 4-42

    Current Loop Cable Wiring ..... 4-44

## List of Tables

Table 1: Typical port address usage .....	2-2
Table 2: Switch settings(DFlex-2/-4, DFlex-2/-4/Fast) .....	2-3
Table 3: Switch settings(DFlex-8) .....	2-4
Table 4: Typical IRQ assignments .....	2-6
Table 5: Baud rates - DFlex/Fast.....	2-7
Table 6: Multiuser DOS: port details .....	3-9
Table 7: DB-9 pinouts - DFlex.....	4-5
Table 8: DB-37 pinouts -DFlex-4; DFlex-4/Fast .....	4-6
Table 9: DFlex-8 DB-78 pinouts.....	4-7
Table 9(continued): DFlex-8 DB-78 pinouts .....	4-8
Table 10: DB-9 pinouts - DFlex I/O Box.....	4-10
Table 11: SLIM pinouts .....	4-11
Table 12: SLIM socket pinouts .....	4-24
Table 13: SLIM socket pinouts .....	4-29
Table 14: SLIM socket pinouts .....	4-36
Table 15: SLIM socket pinouts .....	4-43

## List of Figures

Figure 1: DFlex-8 adapter .....	1-5
Figure 2: DFlex-4; DFlex-4/Fast adapter .....	1-5
Figure 3: DFlex-2; DFlex-2/Fast adapter .....	1-5
Figure 4: DFlex - 20 port configuration .....	1-6
Figure 5: Problem summary sheet.....	1-8
Figure 6: DIP switch block SW1.....	2-3
Figure 7: IRQ jumper block J1 .....	2-5
Figure 8: SLIM socket, port number relationship .....	2-9
Figure 9: Multiuser DOS: switch settings .....	3-10
Figure 10: Multiuser DOS: IRQ settings.....	3-10
Figure 11: OS/2: switch settings .....	3-13
Figure 12: OS/2 IRQ settings .....	3-13
Figure 13: QNX 2.XX: switch settings .....	3-15
Figure 14: QNX 2.XX: IRQ settings.....	3-16
Figure 15: QNX 4.XX: switch settings .....	3-19
Figure 16: QNX 4.XX: IRQ settings.....	3-19
Figure 17: QNX 4.XX: switch settings .....	3-20
Figure 18: QNX 4.XX: IRQ settings.....	3-21
Figure 19: SCO Unix: switch settings.....	3-24
Figure 20: SCO Unix: IRQ settings .....	3-24
Figure 21: Windows 3.XX: switch settings .....	3-34
Figure 22: Windows 3.XX: IRQ settings .....	3-34
Figure 23: Windows 95: switch settings .....	3-39
Figure 24: Windows 95: IRQ settings.....	3-40
Figure 25: Windows NT: switch settings.....	3-45
Figure 26: Windows NT: IRQ settings .....	3-46

---

Figure 27: DFlex I/O Box .....	4-9
Figure 28: DFlex-2/-2/Fast: SW1 factory settings .....	4-13
Figure 29: DFlex-2/-2/Fast: J1 factory setting .....	4-14
Figure 30: DFlex-4; DFlex-4/Fast: SW1 factory settings .....	4-15
Figure 31: DFlex-4; DFlex-4/Fast: J1 factory setting .....	4-16
Figure 32: DFlex-8: SW1 factory settings .....	4-17
Figure 33: DFlex-8: J1 factory setting .....	4-18
Figure 34: SLIM insertion.....	4-19
Figure 35: SLIM removal.....	4-20
Figure 36: RS-232; RS-232/Fast SLIM: partial schematic .....	4-22
Figure 37: RS-485/422 SLIM partial schematic .....	4-27
Figure 38: RS-485/422 wiring diagram (4 wire).....	4-30
Figure 39: RS-485/422 wiring diagram (2 wire).....	4-31
Figure 40: RS-423 SLIM partial schematic .....	4-34
Figure 41: RS-423 wiring diagram (4 wire).....	4-37
Figure 42: RS-423 wiring diagram (all wire).....	4-37
Figure 43: 20mA Current Loop schematic.....	4-40
Figure 44: Current Loop wiring diagram(4 wire) .....	4-44



# Chapter 1: Introduction

---

- Introduction ..... 1-1
- Manual Overview ..... 1-1
  - Conventions & Symbols ..... 1-2
- Product Overview ..... 1-3
  - DFlex Adapter..... 1-4
  - DFlex Software ..... 1-7
- Customer Service Overview ..... 1-7
- RMA Overview ..... 1-10



## Introduction

This section contains an overall description of the DFlex manual, the DFlex product, Connect Tech 's technical services, Return Merchandise Authorization and warranty repair policies. The organization of the information is as follows:

- Manual Overview - describes the structure of the manual and the conventions the manual uses.
- Product Overview - describes the DFlex, its features and specifications.
- Customer Services Overview - describes the various customer support services available to users of Connect Tech products.
- RMA Overview - describes the RMA policy and procedures for all Connect Tech products.

## Manual Overview

The purpose of the DFlex User's Manual is to help you install the DFlex as effortlessly as possible. The manual includes four main sections:

- Introduction - the section you are currently reading, covers the DFlex features; Connect Tech's customer services; and return merchandise authorization (RMA) policies and procedures.
- Hardware Installation - describes installation of the DFlex adapter.
- Software Installation - discusses the installation of the DFlex device drivers under various operating systems.

**Note:**

*We recommend that you read both the **Hardware Installation** and **Software Installation** sections before you attempt to install the DFlex adapter.*

- Appendices - the appendices contain information on electrical pinouts, product specifications such as power requirements; default jumper and DIP switch settings; and other technical information.

### Conventions & Symbols

This manual uses the following conventions:

- In most cases the font for file names and command statements is Arial Narrow Bold 9pt. An example is:

**DEVICE=DFLEX.SYS p=280 P=288**

- *Note: the "Note" convention informs you of important messages, exceptions, or special cases.*

- *Example: the "Example" convention outlines hardware and software installation examples.*

- *Technical Tip: the "Technical Tip" convention offers technical tips to assist you in hardware and software installation or problems*

## WARNING

*The "Warning" convention advises you to take certain precautions in order to avoid possible damage to your Connect Tech product.*



*This message warns you that your Connect Tech product is very sensitive to static electricity. Make sure that before handling the product you practice proper ESD procedures.*

## Product Overview

The DFlex adapters are high performance multi-port serial adapters that allow you to connect up to 8 serial devices through one expansion slot.

Your DFlex product consists of the following components:

- DFlex adapter
- Cable harness or external connector box

**Note:** *The DFlex-2 and DFlex-2/Fast does not require a cable harness or external connector box.*

- DFlex DOS device drivers

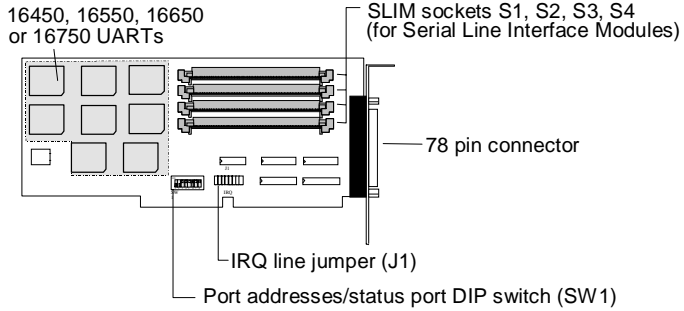
## **DFlex Adapters**

DFlex adapters provide the high speed interfaces between a host computer and multiple external serial devices. DFlex adapters include features such as:

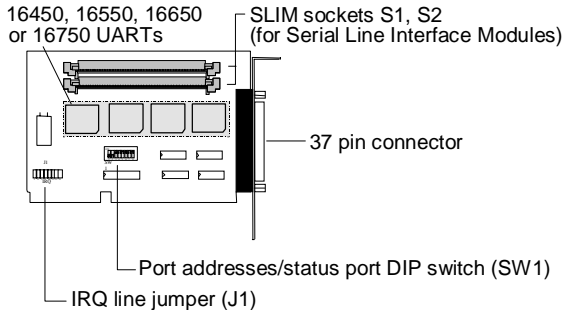
- 2, 4, or 8 asynchronous serial ports out of one slot.
- RS-232, RS-485/422, RS-423 or 20mA Current Loop interfaces.
- Different models of DFlex adapters may reside in a host computer offering up to 32 ports per system.
- 16450, 16550, 16650 or 16750 UARTs control each port.
- An addressable status control register to improve performance.
- Each port on a DFlex-2/-4/-8 has independent baud rate selection offering baud rates from 50 - 115K baud, with 5, 6, 7 or 8 data bits and 1, 1.5, 2 stop bits, odd or even parity.
- Each port on a DFlex-2/-4/Fast has independent baud rate selection offering baud rates from 200 - 460K baud, with 5, 6, 7 or 8 data bits and 1, 1.5, 2 stop bits, odd or even parity.
- On board DIP switch allows the selection of ports 1 & 2 as COM1 and COM2. It provides 8 predefined I/O address sets and 8 predefined status port addresses.
- Jumpers on the board give the user a choice of 8 IRQ lines to run the board at. The on board DIP switch also provides the choice of running the DFlex on 1 or 2 or no hardware interrupts.
- System requirements are one full (DFlex-8) or half-length (DFlex-2/-4; DFlex-2/-4/Fast) ISA bus compatible slot; one available IRQ line.

**Figures 1, 2 and 3** show the locations of various hardware components of the DFlex-2/-4/-8 adapters.

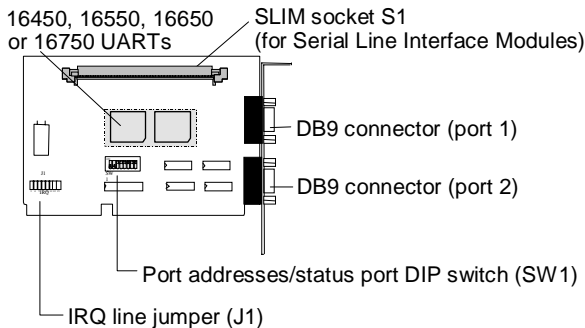
**Figure 1:** *DFlex-8 adapter*



**Figure 2:** *DFlex-4; DFlex-4/Fast adapter*

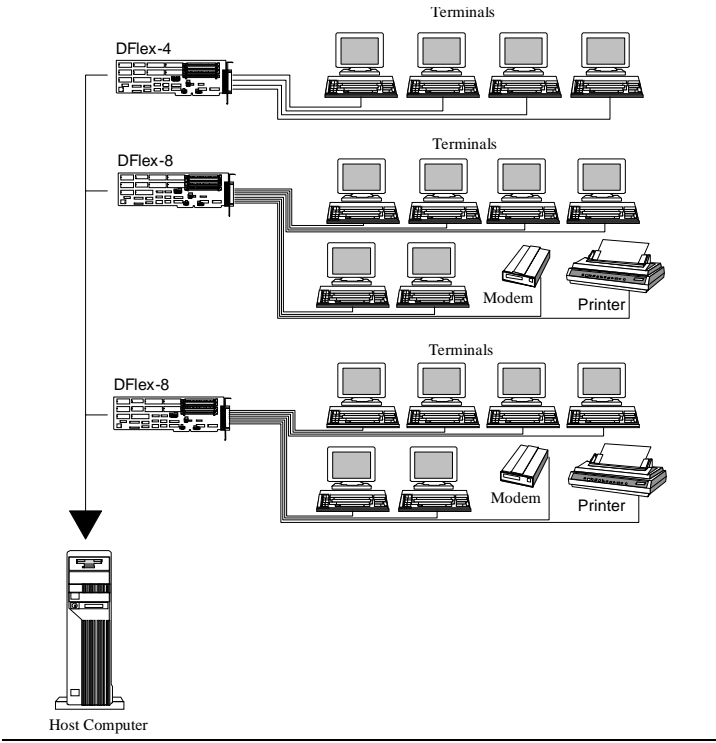


**Figure 3:** *DFlex-2; DFlex-2/Fast adapter*



The DFlex adapters can accommodate both small and large multi-channel applications. You can combine different DFlex adapters in a single computer, up to a maximum of 32 ports per system. **Figure 4** below represents a sample configuration for a system requiring 20 ports.

**Figure 4:** *DFlex - 20 port configuration*



**DFlex Software**

To install your DFlex adapter under different operating systems see **Chapter 3: Software Installation**.

**Customer Service Overview**

If you experience difficulties after reading the manual and using the product, contact the Connect Tech reseller from which you purchased the product. In most cases the reseller can help you with product installation and difficulties.

In the event that the reseller is unable to resolve your problem, our highly qualified support staff can assist you. Please refer to and complete the problem summary sheet found in **Figure 5** before contacting us.

**Figure 5:** *Problem summary sheet*

<b>Problem Description</b>	
<b>Connect Tech Product Description</b>	
Product:	Revision no.:
Product serial no.:	No. of serial ports:
IRQ selected:	Base address selected:
I/O port address selected:	
Device driver:	Revision no.:
<b>System Description</b>	
Operating system:	Revision no.:
System type & manufacturer:	
Amount of RAM:	CPU type/speed:
Video adapter: <input type="checkbox"/> 8 bit <input type="checkbox"/> 16 bit	Settings:
Network adapter: <input type="checkbox"/> 8 bit <input type="checkbox"/> 16 bit	Settings:
Hard disk adapter:	Settings:
Tape adapter:	Settings:
Other serial adapters	Settings:
Other adapters:	Settings:
Devices connected to ports:	

We offer three ways for you to contact us:

**Mail/Courier**

You may contact us by letter and our mailing address for correspondence is:

Connect Tech Inc.  
c/o Customer Service  
42 Arrow Road  
Guelph, Ontario  
Canada N1K 1S6

**Email/Internet**

You may contact us through the Internet. Our email and URL addresses on the Internet are:

sales@connecttech.com  
support@connecttech.com  
www.connecttech.com

**Note:**

1. *You can submit your technical support questions to our customer support engineers via our Internet email address*  
*OR*
2. *You can refer to our knowledge database found in the Customer Support section of our World Wide Web site.*  
*OR*
3. *You can fill out the problem summary form, found in the Customer Support section of our World Wide Web site and submit it to our customer support engineers via the Web.*  
*OR*
4. *You can obtain the latest versions of software drivers and manuals from the Customer Support section of our World Wide Web site.*

**Telephone/Facsimile**

Customer Support representatives are ready to answer your call Monday through Friday, from 9:00 a.m. to noon and 1:00 p.m. to 5:00 p.m. Eastern Standard Time. Our numbers for calls are:

Telephone: 519-836-1291  
800-426-8979  
Facsimile 519-836-4878 (on-line 24 hours)

**RMA Overview**

Connect Tech products requiring warranty or non warranty repairs need an RMA number. To obtain a Return Merchandise Authorization (RMA) Number please contact us in the following manner:

- Go to the **RMA Request Form** found in the **Support Center** on our website:

[www.connecttech.com](http://www.connecttech.com)

- Telephone, fax, email or mail us at:

Connect Tech Inc.  
Technical Support

42 Arrow Road  
Guelph, Ontario

Canada N1K 1S6

Phone: 519-836-1291

800-426-8979

Facsimile: 519-836-4878

Email: [support@connecttech.com](mailto:support@connecttech.com)

Include with the product, proof of purchase (including date of purchase), a description of the problem and the RMA number. Clearly display the RMA number on the external packaging. Please refer to the Limited Warranty for further restrictions or requirements.



*Your DFlex adapter is very sensitive to static electricity. Make sure you wear an anti-static wrist-band before you remove the adapter from your computer. When you remove the board from your computer, handle it only by the edges and place it on the anti-static bag or an anti-static mat.*

**Note:**

- 1. Please pack the item for repair securely and ship it prepaid and insured. Connect Tech is not liable for damage or loss to the product due to shipping.*
- 2. Connect Tech will not accept items for repair without an RMA number.*
- 3. Connect Tech will not accept items for repair shipped freight collect.*



# Chapter 2: Hardware Installation

---

- Introduction ..... 2-1
- Configuration..... 2-1
  - Port Addresses ..... 2-2
    - Custom Port Addresses ..... 2-3
  - Status Port Address ..... 2-4
    - Custom Status Port Addresses ..... 2-4
- Interrupt Selection..... 2-5
- Baud Rate Selection: DFlex/Fast..... 2-6
- Serial Line Interface Modules (SLIM) ..... 2-8
  - SLIM Installation ..... 2-8
  - SLIM compatibility ..... 2-11
- Installing the DFlex Adapter in your System ..... 2-11



## Introduction

Hardware installation involves configuration of the following DFlex products:

- The DFlex-2; DFlex-2/Fast adapter
- The DFlex-4; DFlex-4/Fast adapter
- The DFlex-8 adapter

*Note: Please refer to **Chapter 3: Software Installation** for installation of your DFlex board under certain operating systems.*

The following sections detail how to change the field configurable parameters. The setting of these will depend on the number of boards installed and the existing configuration of your PC.

## Configuration

You must configure various settings and options before installing your DFlex adapter in your computer. In order to insure a successful installation, please follow the steps in the order specified below.

1. Selection of I/O port addresses.
2. Selection of the status port address.
3. Selection of IRQs.
4. Installation of Serial Line Interface Modules (SLIM).
5. Configuration of RS-232 and/or RS-485/422 and/or RS-423 and/or Current Loop options.
6. Installing the DFlex adapter in your computer.



*Your DFlex adapter is very sensitive to static electricity. Make sure you wear an anti-static wrist-band before you remove the card from the anti-static shipping bag. When you remove the board from the anti-static bag, handle it only by the edges and place it on the anti-static bag or an anti-static mat.*

### Port Addresses

You configure port addresses with DIP switches 1 to 5 on SW1. Switches 3 to 5 select a set of port addresses for the ports, while you can override the setting for port 1 and 2 with switch 1 and 2 respectively. When DIP switch 1 is on, then port 1 is COM1 at 3F8 hex. If DIP switch 2 is on then port 2 is COM2 at 2F8 hex. These settings will override the addresses specified by DIP switches 3, 4 and 5. Please refer to **Figure 6** for a description of switch block SW1, while **Tables 2** and **3** provide the switch settings for the various port address sets

However many other devices may require port addresses in your computer's I/O address space. In most cases the factory setting is sufficient, but when there is a conflict, SW1 may require a different setting. **Table 1** summarizes typical I/O port address usage.

## WARNING

*Do not use a pencil to set the DIP switches as the lead graphite may short-circuit the switch.*

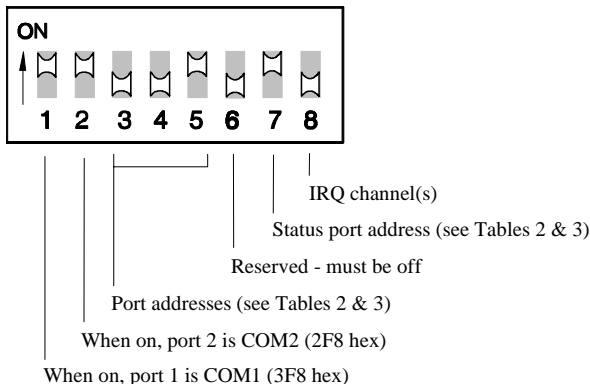
**Table 1:** Typical port address usage

Port Address (Hex)	Usage
000 - 0FF	Reserved
170 - 177	Fixed disk controller (primary)
1F0 - 1F7	Fixed disk controller (secondary)
200 - 207	Game port
278 -27F	Parallel port (LPT2)
2C0 - 2CF	EGA video adapter (#2)
2F8 - 2FF	Asynchronous serial port (COM2)
360 - 36F	Parallel port (LPT1)
370 - 377	Floppy disk controller (secondary)
378 - 37F	Parallel port (LPT1)
380 - 38F	SDLC adapter (#2)
3A0 - 3AF	SDLC adapter (#1)
3B0 - 3BF	Video adapters
3F0 - 3F7	Floppy disk controller (primary)
3F8 - 3FF	Asynchronous serial port (COM1)

### Custom Port Addresses

You can generate other port addresses by making changes to the PALs found on the DFlex adapters. If you require specific port addresses not listed in **Tables 2 and 3** please contact the Connect Tech sales department for further information.

**Figure 6:** DIP switch block SW1



**Table 2:** Switch settings (DFlex-2/-4, DFlex-2/-4/Fast)

Switch			Port (hex)				Status Port
3	4	5	1	2	3	4	
on	on	on	200	208	210	218	240
on	on	off	240	248	250	258	280
on	off	on	280	288	290	298	2C0
on	off	off	2C0	2C8	2D0	2D8	300
off	on	on	1B0	1B8	1C0	1C8	188
off	on	off	2B0	2B8	2C0	2C8	288
off	off	on	290	298	2A0	2A8	2D0
off	off	off	190	198	1A0	1A8	1D0

**Note:** You enable the status port when switch 7 is in the on position. You disable the status port when switch 7 is in the off position.

**Table 3: Switch settings(DFlex-8)**

Switch			Port								Status
3	4	5	1	2	3	4	5	6	7	8	Port
on	on	on	200	208	210	218	220	228	230	238	240
on	on	off	240	248	250	258	260	268	270	278	280
on	off	on	280	288	290	298	2A0	2A8	2B0	2B8	2C0
on	off	off	2C0	2C8	2D0	2D8	2E0	2E8	2F0	2F8	300
off	on	on	300	308	310	318	320	328	330	338	340
off	on	off	2B0	2B8	2C0	2C8	2D0	2D8	2F0	2F8	288
off	off	on	290	298	2A0	2A8	2B0	2B8	2C0	2C8	2D0
off	off	off	190	198	1A0	1A8	1B0	1B8	1C0	1C8	1D0

**Note:** You enable the status port when switch 7 is in the on position. You disable the status port when switch 7 is in the off position.

### Status Port Address

The DFlex board provides a status port that indicates which ports, if any, are causing the interrupts. When read, the port will indicate a one (1) if the corresponding port has an interrupt request pending and a zero (0) if not. The least significant data bit (D0) represents the status of port 1.

In multi-card installations the address for the status port on each card must be unique. DIP switch 7, combined with the selection of the port addresses on DIP switches 3, 4 and 5, determines the status port address. **Tables 2** and **3** indicate the relationship.

### Custom Status Port Addresses

We have replaced the status port buffering chip on the DFlex-2; DFlex-2/Fast; DFlex-4; DFlex-4/Fast adapters (revision B or later) and the DFlex-8 adapter (revision D or later) with a GAL (programmable logic device). To maintain compatibility we programmed this GAL with the status port addresses of previous versions of DFlex adapters. You can order custom versions of this GAL if your application requires an address not supported in the standard version. Please contact Connect Tech Customer Support for more details regarding custom GALs.

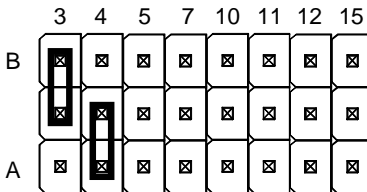
## Interrupt Selection

You can configure DFlex boards to use one, two or no interrupt request lines. To select the appropriate configuration, you must program DIP switch 8 on SW1 and the IRQ jumper block J1. When DIP switch 8 is on, all DFlex communication ports will interrupt on the A channel. When switch 8 is off, the odd numbered DFlex ports will interrupt on the A channel, while the even numbered DFlex ports will interrupt on the B channel.

IRQ jumper block J1 allows the assignment of IRQ lines to both the A and B channels. If your application requires no interrupts then you can remove both jumpers from jumper block J1. To assign interrupts to either channel, go to the posts under the selected IRQ line number and install the jumper(s) between the centre post and the A post (A channel), and/or between the centre post and the B post (B channel).

COM1 and COM2 normally use IRQ 4 and IRQ 3 respectively. If you use the first two ports as COM1 and COM2, set switch 8 on SW1 to the off position and install a jumper between the centre post and the A post on J1 under IRQ 4 (COM1). You should install the other jumper between the centre post and the B post on J1 under IRQ 3 (COM2). If you configure only one of the two ports as a standard COM1 or COM2, then you can relocate or remove the other jumper according to the requirements of the controlling software. Please refer to **Figure 7** for an explanation of IRQ jumper block J1.

**Figure 7:** *IRQ jumper block J1*



**Note:** *this is an example of shows J1 selected for IRQ 3 and 4 on channels B and A respectively.*

Many other devices such as the keyboard and disk drives also require an IRQ. **Table 4** shows some typical IRQ assignments.

**Table 4:** *Typical IRQ assignments*

IRQ	Device
0	Timer output
1	Keyboard
2	Reserved
3	COM2, COM4, SDLC
4	COM1, COM3, SDLC
5	Unassigned (typically)
6	Floppy disk controller
7	LPT1
8	Real-time clock
9	Reserved
10	Unassigned (typically)
11	Unassigned (typically)
12	Unassigned (typically)
13	Co-processor
14	Primary fixed disk controller
15	Secondary fixed disk controller

In most cases the default IRQ setting for your DFlex adapter is satisfactory. If an IRQ conflict exists between the DFlex adapter and another expansion device, you must choose another IRQ. To select an IRQ simply install the jumper across the corresponding pins for that IRQ on J1.

#### **Baud Rate Selection: DFlex/Fast**

The DFlex-2/Fast and the DFlex-4/Fast are high speed two and four port serial adapters for ISA bus compatible computers. Through the use of large FIFO buffers in the 16650 and 16750 UARTs as well as high speed circuitry, DFlex/Fast adapters offer ideal solutions for applications requiring serial communications up to 460K baud.

The DFlex/Fast adapters are capable of data transmission rates from 200 - 460K baud. Since most commercial software is not aware of the higher baud rates (greater than 115k baud), when you set a baud rate in your software it will actually be **FOUR TIMES** faster on the DFlex/Fast adapter.

**Example:**

*If you want to run the DFlex/Fast adapter at 230.4K baud, you would set your software to 57.6K baud. Please refer to Table below for a cross reference of standard baud rates to DFlex/Fast baud rates.*

**Note:**

*Some baud rates are not available with the DFlex/Fast adapters (i.e. 50 and 57.6K baud)*

**Table 5:** Baud rates - DFlex/Fast

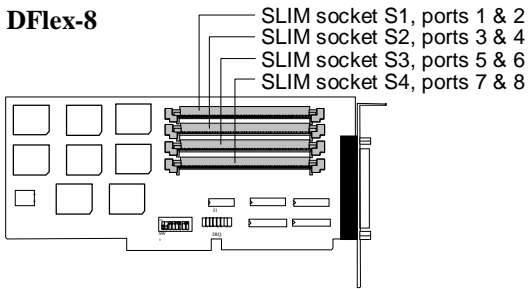
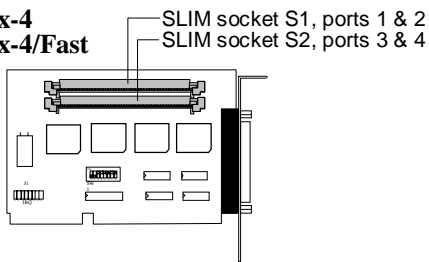
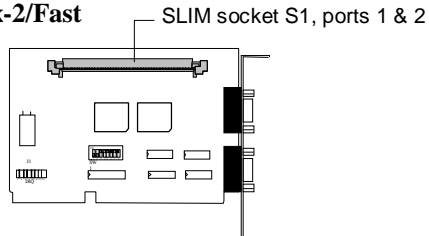
<b>Standard Baud Rate. (set in software)</b>	<b>DFlex/Fast Baud Rate (4X standard)</b>
50	200
75	300
150	600
300	1200
600	2400
1200	4800
2400	9600
4800	19.2k
7200	28.8k
9600	38.4k
19.2k	76.8k
38.4k	153.6k
57.6k	230.4k
115.2K	460.8K

### **Serial Line Interface Modules (SLIM)**

DFlex products can accept interchangeable electrical line interfaces. These Serial Line Interface Modules (SLIM) provide the electrical interface for two asynchronous communication ports. If you order RS-232 or RS-232/Fast modules please refer to **Appendix E: RS-232 Option** for more technical information. If you order RS-485/422 modules please refer to **Appendix F: RS-485/422 Option** for more technical information. If you order RS-423 modules please refer to **Appendix G: RS-423 Option** for more technical information. If you order 20mA current loop modules please refer to **Appendix H: 20mA Current Loop Option** for more technical information.

### **SLIM Installation**

The DFlex and DFlex/Fast adapters have one, two or four SLIM sockets which accept line transceiver modules. Each transceiver module provides the RS-232 or RS-485/422 or RS-423 or 20mA current loop receivers and transmitters to condition two serial ports. SLIM socket S1 interfaces ports 1 and 2. SLIM socket S2 interfaces ports 3 and 4. SLIM socket S3 interfaces ports 5 and 6. SLIM socket S4 interfaces ports 7 and 8. Refer to **Figure 8** for the location and orientation of the SLIM sockets on the DFlex and DFlex/Fast adapters.

**Figure 8:** *SLIM socket, port number relationship***DFlex-8****DFlex-4**  
**DFlex-4/Fast****DFlex-2**  
**DFlex-2/Fast**

To insert a SLIM into its connector follow these steps:

1. Place the SLIM into the socket almost vertically (about 75 degree angle), making sure to align it properly before inserting it into the socket.
2. Press downward and sideways on the SLIM until it latches into the socket. **Do NOT force the SLIM**, the installation process requires a small amount of force and should be very smooth and easy. If you experience resistance, check the alignment and insertion depth of the SLIM. Refer to **Appendix D: SLIM Insertion/Removal** regarding the insertion of a SLIM.

To remove a SLIM from its connector follow these steps:

1. Using both hands, place your thumbs on the metal clips that hold the SLIM into the socket, and place your index fingers on the edge of the SLIM.
2. Push outwards (with your thumbs) on the metal clips until you release the SLIM from the clips. Your index fingers can then raise the SLIM past the clips. You can then remove the SLIM from the DFlex adapter. The force required to open the metal clips is small and the SLIM naturally springs upwards when the clips are open wide enough. If removal is difficult, then you are probably trying to raise the SLIM before the clips are open. Refer to **Appendix D: SLIM Insertion/Removal** regarding the removal of a SLIM.



*The RS-232, RS-232/Fast, RS-485/422, RS-423 and 20mA current loop SLIMs are very sensitive to static electricity. Make sure you wear an anti-static wrist-band before you remove the SLIMs from the anti-static shipping bag. When you remove the board from the anti-static bag, handle it only by the edges and place it on the anti-static bag or an anti-static mat.*

You should label the DB9 pin connectors to indicate the type of interface provided on the port. Please refer to **Figure 8** for the SLIM socket and port number relationship.

On a DFlex-2 and DFlex-2/Fast, port 1 is the top DB9 connector on the back of the board. The DFlex-4, DFlex-4/Fast and DFlex-8 adapters ship with a cable harness consisting of four or eight DB9 connectors. This harness attaches to the back of the board.

Once again you should mark the small labels provided with the board and apply them to each DB9 pin connector to indicate the interface provided on that port.

### SLIM compatibility

Some of the standard SLIM modules are not functional with the DFlex/Fast adapters due to the faster baud rates. The following Connect Tech Serial Line Interface Modules (SLIM) are compatible with the DFlex-2/Fast and DFlex-4/Fast adapters:

- RS-232/Fast part number: SIMM-F232
- RS-485/422 part number: SIMM-RS485
- RS-423 part number: SIMM-RS423

### Installing the DFlex Adapter in your System

To install your DFlex adapter in your computer follow these steps:



*Computer components are very sensitive to static electricity. Make sure that you wear an anti-static wrist-band when installing adapters in your computer. Handle the adapter by its edges and place it on the anti-static bag or an anti-static mat.*

1. Turn the power off to your computer.
2. Open your computer to expose the expansion slots (consult the system documentation for information on this procedure.)
3. Choose an available full length 8 or 16-bit expansion slot.
4. Remove the screw and the expansion slot cover from the slot you select and save both.

5. Place the DFflex adapter in the expansion slot and push down gently until the card seats fully in the slot.

**Note:** *Do not force the card into the expansion slot. If you meet a great deal of resistance, remove the board and try again.*

6. Align the mounting bracket and secure the board with the screw that you saved.
7. Close your computer.

# Chapter 3: Software Installation

---

- Introduction ..... 3-1
- Configuration..... 3-1
  - DOS 3.XX - 6.XX..... 3-2
    - COMSET.EXE..... 3-2
    - DFLEX.SYS..... 3-3
    - CTIMODE..... 3-3
  - Accessing Ports..... 3-3
    - Character Device Access..... 3-4
    - INT 14h Access..... 3-4
  - Linux ..... 3-7
  - Multiuuser DOS 7 GOLD..... 3-8
    - Configuration ..... 3-8
  - OS/2: DFlex-2/-2/Fast as COM3 & COM4..... 3-11
    - Configuration ..... 3-12
  - QNX 2.XX ..... 3-14
    - Configuration ..... 3-14
  - QNX 4.XX ..... 3-17
    - Configuration ..... 3-17
  - QNX 6.XX ..... 3-22
  - SCO Unix..... 3-23
    - Configuration ..... 3-23
    - Other Configurations..... 3-29
  - Solaris ..... 3-31
  - Windows 3.XX: DFlex-2/-2/Fast as COM3 & COM4.... 3-32
    - Configuration ..... 3-33
  - Windows 95 ..... 3-35
    - DFlex Enhanced Driver ..... 3-36
      - Installation ..... 3-37
      - UART/FIFO Configuration..... 3-38
    - Configuration ..... 3-39
  - Windows NT..... 3-43
    - DFlex Enhanced Driver ..... 3-43
    - Configuration ..... 3-44



## Introduction

DFlex boards are standard multi-port serial adapters that utilize 16450, 16550, 16650 or 16750 UARTS. In many cases, users have software that will interface directly to the DFlex boards. Many operating systems come with handlers to control access to multiple 8250 style UARTS. This section covers configurations for the following operating systems:

- DOS 3.XX - 6.XX
- Linux
- Multiuser DOS
- OS/2 2.XX (DFlex-2 only)
- QNX 2.XX
- QNX 4.XX
- QNX 6.XX
- SCO Unix
- Solaris
- Windows 3.XX (DFlex-2 only)
- Windows 95
- Windows NT

### ***Technical Tips:***

1. *Your DFlex adapter may ship with diskettes that include README files. Please examine these files for technical tips or release notes concerning installation and configuration of various device drivers and software utilities.*
2. *If you did not receive a driver diskette for your operating system or you require additional information, please go to the **Download Zone** of the **Support Center** on the **Connect Tech** website for product manuals, installation guides and device driver software.*

## Configuration

The following sections detail some recommended configurations for DFlex boards running under various operating systems. These settings will depend on the number of boards installed and the existing configuration of your PC.

The configuration steps you must consider are:

- port addresses
- status port address
- interrupt request lines

**DOS 3.XX - 6.XX**

Many DOS applications are designed to directly control the hardware of an 8250 style UART. For some applications, the DOS device driver provided with the DFlex will help to integrate the extra communication ports quickly and easily into the system.

***Technical Tip***

1. *You can run under DOS the DOS programs **porttest.exe** and **portfind.exe** to verify your settings and assure you have no hardware conflicts. You will find these programs on the **DFlex DOS Driver** diskette (p/n: DISK306).*
2. *If you did not receive a DOS driver diskette or you require additional information, please go to the **Download Zone** or the **Knowledge Database in the Support Center** on the **Connect Tech** website for product manuals, installation guides, device driver software and technical tips. If these sources do not provide you with the help you need please contact a **Connect Tech Technical Support Representative** via email, telephone or fax for further information (numbers and addresses are found inside the front cover of the manual).*

The Connect Tech DOS device driver will support up to a maximum of 32 serial ports. The standard COM driver and BIOS will only support up to four ports. If your total number of installed ports is four or less, use **COMSET** to set the port address to allow standard software access. To access more ports, you will need to mount the **DFLEX.SYS** device driver.

**COMSET.EXE**

As mentioned earlier, **COMSET** allows you to set the port addresses for standard software access (up to four ports). The syntax for **COMSET** is:

**COMSET** [[COM]n HHHH]

<b>COMSET</b>	will display up to four non-zero com address settings
<b>COMSET COM2 2f8</b>	will set COM2 to 2f8 (hex)
<b>COMSET COM3 0</b>	will set COM3 off

## DFLEX.SYS

DFLEX.SYS is a device driver that allows you to set port addresses for software access of more than four ports and up to 32 ports . To install the device driver, add the following command to your CONFIG.SYS file:

**DEVICE = DFLEX.SYS [options]**

Where [options] are:

- P=hhh**      **hhh** specifies the I/O address of the 8250/16450/16550/16650/16750 UART.
- N=d**        this parameter specifies an offset for the communication port numbers to start at.
- D=name**     this parameter changes the name of the ports to something other than COM.

***Note:** You must specify at least one option*

### **Example 1:**

*Four ports ( com1 .. com4 )*  
DEVICE=DFLEX.SYS P=3f8 P=2f8 P=210 P=218

### **Example 2:**

*Four ports ( com3 .. com6 )*  
DEVICE=DFLEX.SYS P=200 P=208 P=210 P=218 N=3

### **Example 3:**

*Four ports ( serial1 .. serial4 )*  
DEVICE=DFLEX.SYS P=330 P=338 P=340 P=348 D=SERIAL

## CTIMODE

The CTIMODE command allows you to configure the extra serial ports. It is used with the COM name:

**CTIMODE COMn:baud,parity,databits,stopbits**

## Accessing Ports

You can access the 8250/16450/16550/16650/16750 UARTS from DOS through the driver DFLEX.SYS. We provide two methods of access; character device access and software interrupt 14h access.

**Character Device Access**

Character device access provides a "high level" interface which is appropriate for simple applications and tests. Each port is given a device name which you can access similar to a file. The device name is formed by concatenating the port number to the name ( **COM** if not specified by the **D=** command ). For example, if two ports are installed with the parameter **N=2**, then the device names will be **COM2** and **COM3**.

Some programming languages will assume that access to **COMn** is limited to the number of communication ports supported by the computers BIOS. To avoid this problem, the name can be changed. If two ports are installed with the parameters **D=SERIAL** the names will be **SERIAL1** and **SERIAL2**. In this case, the **N=** parameter is not added to the number of the name.

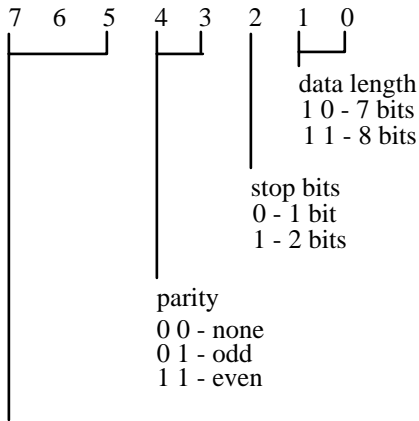
**INT 14h Access**

DFlex DOS driver provides the standard four INT 14h functions for the additional ports supported. To interface to these functions, **DX** is set to the port number minus 1. If the **N=** parameter has been specified, this value must be added into the **DX** to skip the standard ports.

**Function 0 - Initialize the port**

Input: ah = 0  
 al = baud, parity, length  
 dx = channel ( 0 = com1, 1 = com2, ... )

Bit designations for al are:



baud rate  
 0 0 0 - 110 bps  
 0 0 1 - 150 bps  
 0 1 0 - 300 bps  
 0 1 1 - 600 bps  
 1 0 0 - 1200 bps  
 1 0 1 - 2400 bps  
 1 1 0 - 4800 bps  
 1 1 1 - 9600 bps

Return: ax as per **Function 3**

**Function 1 - Output a character**

Input: ah = 1  
 al = character  
 dx = port number

Return: timeout if bit 7 of ah is set

---

---

**Function 2 - Receive character**

Input: ah = 2  
dx = port number

Return: ah = port status ( timeout if bit 7 is set )  
al = character received

---

---

---

---

**Function 3 - Return port status**

Input: ah = 3  
dx = port number

Return: ah = port status  
bit 7 = timeout  
bit 6 = trans shift reg empty  
bit 5 = trans hold reg empty  
bit 4 = break detected  
bit 3 = framing error  
bit 2 = parity error  
bit 1 = over run error  
bit 0 = data ready  
al = modem status  
bit 7 = data carrier detect  
bit 6 = ring indicator  
bit 5 = data set ready  
bit 4 = clear to send  
bit 3 = delta dcd  
bit 2 = delta ri  
bit 1 = delta dsr  
bit 0 = delta cts

---

---

## Linux

Linux is a leading multi-user, multi-tasking operating system for Intel based personal computers. The Linux serial device driver provides an interface between the Linux kernel v.2.2.X or v.2.4.X and a DFlex adapter.

### ***Technical Tip***

1. *You can run under DOS the DOS programs **porttest.exe** and **portfind.exe** to verify your settings and assure you have no hardware conflicts. You will find these programs on the **DFlex DOS Driver** diskette (p/n: DISK306).*
2. *If you did not receive a Linux driver diskette or you require additional information, please go to the **Download Zone** or the **Knowledge Database** in the **Support Center** on the **Connect Tech** website for product manuals, installation guides, device driver software and technical tips. If these sources do not provide you with the help you need please contact a **Connect Tech Technical Support Representative** via email, telephone or fax for further information (numbers and addresses are found inside the front cover of the manual).*

## Multiuser DOS 7 GOLD

This section describes how to install a DFlex adapter into a Multiuser DOS 7 GOLD system. For further information please refer to **Boards and Ports** under the **Installation and Configuration** section of the **Multiuser DOS 7 GOLD Users Guide**.

### *Technical Tip*

1. *You can run under DOS the DOS programs porttest.exe and portfind.exe to verify your settings and assure you have no hardware conflicts. You will find these programs on the **DFlex DOS Driver** diskette (p/n: DISK306).*
2. *If you did not receive a Multiuser DOS driver diskette or you require additional information, please go to the **Download Zone** or the **Knowledge Database** in the **Support Center** on the **Connect Tech** website for product manuals, installation guides, device driver software and technical tips. If these sources do not provide you with the help you need please contact a **Connect Tech Technical Support Representative** via email, telephone or fax for further information (numbers and addresses are found inside the front cover of the manual).*

## Configuration

Multiuser DOS 7 GOLD configures standard serial devices via the CONFIG.EXE utility. To install a DFlex adapter please follow these procedures:

1. Type CONFIG at the C:\ prompt.
2. Select **Boards and Ports**.
3. Hit the **INSERT** key to add another board.
4. Select **Standard Board**.
5. Edit board details as follows:
 

Board Name	you can change it to read DFlex
Board Model	Standard Driver
Number of Ports	2, 4, or 8
IRQ Number	the IRQ selected for the DFlex adapter
I/O Port or Poll Reg.	0000
6. Hit the **ALT** key and then select **Assign/Edit Ports**. Here you can choose one of the predefined stations, modems or printers and assign it to this port.

7. Provide all of the **Port Details** after assigning the port. Set the **Port** and **Port XOR Mask** as per the chart below:

**Table 6:** *Multiuser DOS: port details*

PORT	AND MASK	XOR MASK	STATUS PORT
P1	01	00	***
P2	02	00	***
P3	04	00	***
P4	08	00	***
P5	10	00	***
P6	20	00	***
P7	40	00	***
P8	80	00	***

**Note:**

\*\*\* *The status port depends on the base port addresses selected on DIP switch block SW1 of the DFlex adapter*

Many computers include both COM1 and COM2 directly on the motherboard. The example shown below assumes that both of these ports are standard equipment in your computer.

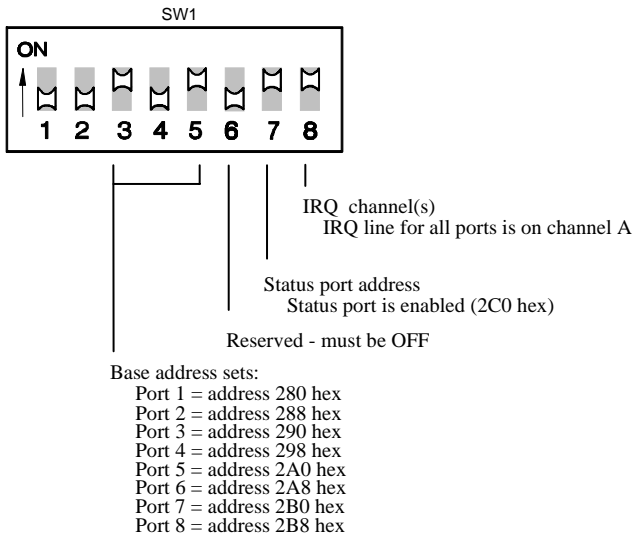
**Example:**

**Figures 9 and 10** describe the DIP switch and jumper settings for your DFlex adapter in a system configured for:

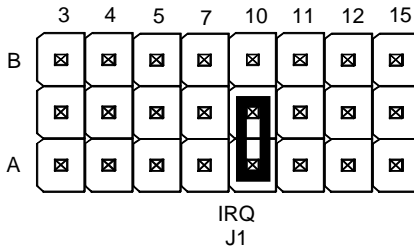
1. A standard serial port at COM1, 3F8 hex, IRQ 4 and a second standard serial port at COM2, 2F8, IRQ 3
2. A DFlex-8 adapter with its serial ports set at port addresses 280, 288, 290, 298, 2A0, 2A8, 2B0, 2B8 hex respectively and its status port at 2C0 hex
3. All the DFlex ports interrupt on channel A, IRQ 10

Please refer to **Figures 1, 2, and 3** in **Chapter 1: Introduction** for the location of switch block SW1 and jumper block J1.

**Figure 9: Multiuser DOS: switch settings**



**Figure 10: Multiuser DOS: IRQ settings**



**Note:** All DFlex ports are interrupting on channel A, IRQ 10.

**OS/2: DFlex-2/-2/Fast as COM3 & COM4**

OS/2 and its standard serial port driver **COM.SYS** allow users to configure their computer systems with up to four serial ports as COM1, COM2, COM3 and COM4. OS/2 and **COM.SYS** require that each serial port have a different port address and IRQ. Most computer systems come with two standard serial ports configured as COM1 (port address 3F8 hex, IRQ 4) and COM2 (port address 2F8 hex, IRQ 3). In most cases you cannot configure these serial ports for other port addresses or IRQs.

**Technical Tip**

1. *You can run under DOS the DOS programs **porttest.exe** and **portfind.exe** to verify your settings and assure you have no hardware conflicts. You will find these programs on the **DFlex DOS Driver** diskette (p/n: DISK306)*
2. *If you did not receive an OS/2 driver diskette or you require additional information, please go to the **Download Zone** or the **Knowledge Database** in the **Support Center** on the **Connect Tech** website for product manuals, installation guides, device driver software and technical tips. If these sources do not provide you with the help you need please contact a **Connect Tech Technical Support Representative** via email, telephone or fax for further information (numbers and addresses are found inside the front cover of the manual).*

The DFlex-2 and DFlex-2/Fast are ideal choices for adding two additional serial ports as COM3 and COM4 under OS/2. The DFlex-2 and DFlex-2/Fast are two port serial adapters with configurable I/O port addresses and IRQs. You can order them with 16450, 16550, 16650 and 16750 style UARTS for applications using the buffering capabilities of the on-chip FIFO (recommended choice).

**Note:**

*There are third party serial drivers for OS/2 that support more than four serial ports with shared interrupts. These drivers also support DFlex adapters. Please contact **Connect Tech Customer Support** for more information.*

**Configuration**

To enable COM3 and COM4 under OS/2, you must add the following statement to the `CONFIG.SYS` file

```
DEVICE=X:\OS2\COM.SYS (n,a,i)
```

where: **X** = the drive letter containing the OS/2 directory  
**n** = the number of the COM port  
**a** = communication I/O port address  
**i** = the IRQ number

**Example**

*Assume that the OS/2 directory and program files are on drive C: and you want to configure the DFlex-2 as follows:*

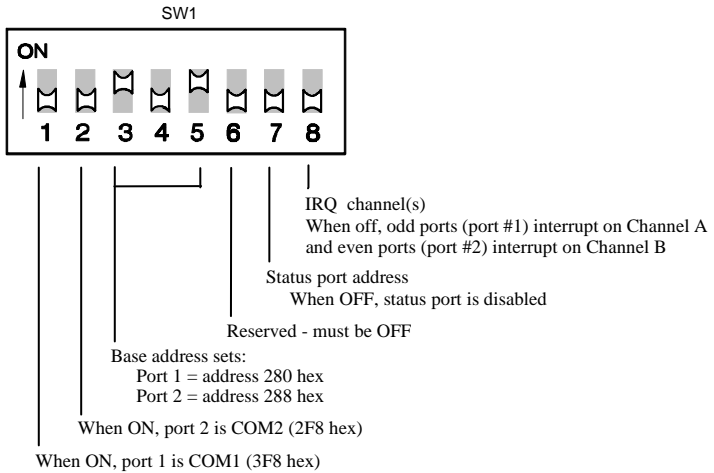
- 1. The DFlex's port 1 configured as COM3 using I/O port address 280 hex and IRQ 10*
- 2. The DFlex's port 2 configured as COM4 using I/O port address 288 hex and IRQ 11*

*Add the following statement to the `config.sys` file*

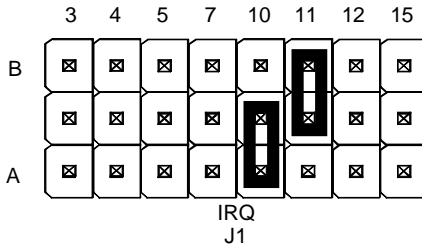
```
DEVICE=C:\OS2\COM.SYS (3,280,10) (4,288,11)
```

**Figure 11** and **Figure 12** show the DFflex-2 and DFflex-2/Fast DIP switch and jumper settings for the preceding example. See **Figure 3** in **Chapter 1:Introduction** for the location of switch block SW1 and jumper J1

**Figure 11: OS/2: switch settings**



**Figure 12: OS/2: IRQ settings - J1**



**Note:** Port 1 (COM3) interrupts on Channel A, IRQ 10 and port 2 (COM4) interrupts on Channel B, IRQ 11.

## QNX 2.XX

When installing DFlex boards under the QNX 2.XX operating system, it is important to note the following:

**Note:**

1. After booting, QNX looks for serial ports at the following addresses: 3F8, 2F8, 280, 288, 290, 2A0, 2A8, 2B0, 2B8, 3E8, 2E8 hex.
2. If QNX finds ports at these addresses, QNX assigns the names \$tty3 (\$smdm), \$tty4 (\$term1), etc.

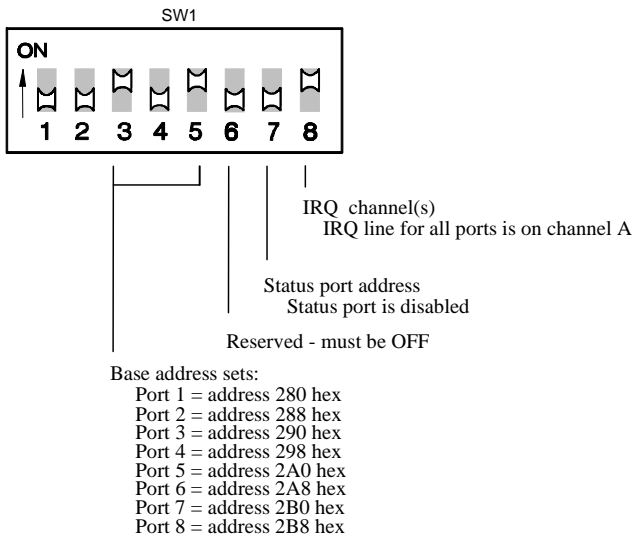
**Technical Tip:** You can use `osconfig` to alter or add to these addresses.

## Configuration

Many computers include both COM1 and COM2 directly on the motherboard. With this in mind, check your computer to see if it has either or both of these ports as standard equipment or as options. To avoid possible conflicts with COM1 and COM2, **Figure 13** describes a recommended DIP switch setting for port addresses. See **Figures 1, 2, and 3** in **Chapter 1: Introduction** for the location of switch block SW1.

**Technical Tip**

1. You can run under DOS the DOS programs `porttest.exe` and `portfind.exe` to verify your settings and assure you have no hardware conflicts. You will find these programs on the **DFlex DOS Driver** diskette (p/n: DISK306)
2. If you did not receive a QNX driver diskette or you require additional information, please go to the **Download Zone** or the **Knowledge Database** in the **Support Center** on the **Connect Tech** website for product manuals, installation guides, device driver software and technical tips. If these sources do not provide you with the help you need please contact a **Connect Tech Technical Support Representative** via email, telephone or fax for further information (numbers and addresses are found inside the front cover of the manual).

**Figure 13:** *QNX 2.XX: switch settings*

In choosing an interrupt request line, you should note that QNX vectors interrupt 3 and 4 to the serial handler. However, QNX enables interrupt 4 only. If you are using interrupt 3, you will have to use the following command to enable interrupt 3:

**Example**

```
stty inton=3
```

If you use an interrupt other than 3 or 4 you will need to use the following commands:

**Example**

```
stty intcp=4,nn
stty inton=nn
```

where *nn* is the interrupt number to be used

**Note:**

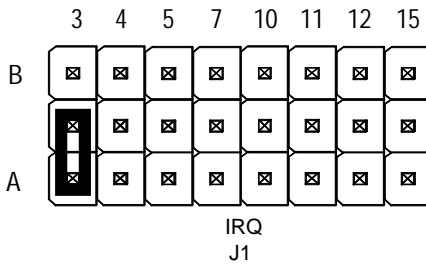
Due to limitations in QNX 2.XX, only interrupts less than or equal to IRQ 7 will work with standard serial port boards.

Use the `stty intcp` command to vector the selected interrupt to the serial handler and the `stty inton` command to enable that interrupt.

*Note: You can find more information on these commands by referring to the `stty` command in your QNX Operating System Manual.*

**Figure 14** shows the recommended IRQ jumper settings. See **Figures 1, 2, and 3** in **Chapter 1: Introduction** for the location of jumper J1.

**Figure 14:** QNX 2.XX: IRQ settings



*Note: All ports are interrupting on channel A, IRQ 3.*

**QNX 4.XX**

QNX 4.XX controls standard serial devices in a system with its standard serial port driver **Dev.ser**. When installing DFlex boards under the QNX 4.XX operating system, refer to **Dev.ser** in the QNX 4 Utilities Reference Manual for more information.

**Configuration**

To install a DFlex adapter under QNX 4.XX add the following entry to your **SYSINIT** file:

**Dev.ser [options] [port[,irq]] &**

Where:

**[port]** is a hex I/O address of a serial port

**[irq]** is a decimal interrupt used by the port

**[options]** are:

<b>-b number</b>	Define initial baud rate (default: 9600).
<b>-C number</b>	Size of canonical input buffer (default: 256).
<b>-d</b>	Set DSR on initially. (default)
<b>-D</b>	Set DSR off initially.
<b>-e</b>	Set options to "edit" mode.
<b>-E</b>	Set options to "raw" mode (default).
<b>-f</b>	Enable hardware flow control. (default)
<b>-F</b>	Disable hardware flow control.
<b>-h number</b>	Define high-water mark for input flow control (default: 3/4 point of input buffer).
<b>-l number</b>	Size of raw input buffer (default: 2048).
<b>-l number</b>	Define low-water mark for input flow control (default: 1/4 point of input buffer).
<b>-m</b>	Disable modem carrier processing (HUP).
<b>-M</b>	Enable modem processing (HUP). (default)
<b>-N name</b>	Prefix to register (default: "ser").
<b>-O number</b>	Size of output buffer (default: 2048).
<b>-p</b>	Enable packet mode
<b>-P</b>	Disable packet mode (default)
<b>-r</b>	Set RTS on initially. (default)
<b>-R</b>	Set RTS off initially.
<b>-s</b>	Enable ohflow split - CTS only required. (default)
<b>-S</b>	Disable ohflow split (CTS and DSR required).
<b>-t number</b>	16550 FIFO threshold (1, 4, 8 or 14). ) disables. (default 0)
<b>-x</b>	Enable software flow control (XON/XOFF)

-X	Disable software flow control (default)
-w	Enable hardware shutdown on SIGPWR
-W	Disable hardware shutdown on SIGPWR (default)

Many computers include both COM1 and COM2 directly on the motherboard. The command line example shown below assumes that both of these ports are standard equipment in your computer.

**Example:**

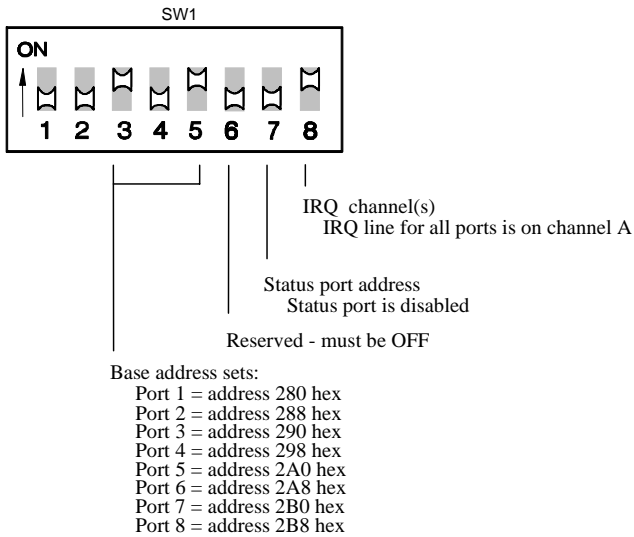
Dev.ser 3f8,4 2f8,3 280,10 288,10 290,10 298,10 2a0,10 2a8,10 2b0,10 2b8,10 &

*The above example configures QNX 4.XX for a standard COM1 port at 3F8 hex, IRQ4; a standard COM2 port at 2F8 hex, IRQ 3 and a DFlex-8 adapter at port addresses 280, 288, 290, 298, 2A0, 2A8, 2B0, and 2B8 hex, IRQ 10 channel A. Please refer to **Figures 15 and 16** for the DIP switch and jumper settings for your DFlex adapter and **Figures 1, 2, and 3** in **Chapter 1: Introduction** for the location of switch block SW1 and jumper block J1.*

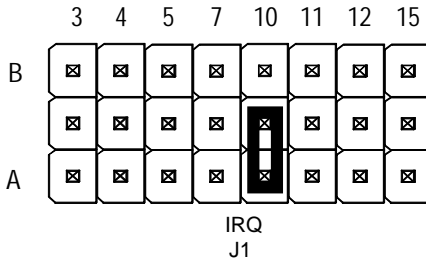
**Technical Tip**

1. You can run under DOS the DOS programs **porttest.exe** and **portfind.exe** to verify your settings and assure you have no hardware conflicts. You will find these programs on the **DFlex DOS Driver** diskette (p/n: DISK306).
2. If you did not receive a QNX driver diskette or you require additional information, please go to the **Download Zone** or the **Knowledge Database** in the **Support Center** on the **Connect Tech** website for product manuals, installation guides, device driver software and technical tips. If these sources do not provide you with the help you need please contact a **Connect Tech Technical Support Representative** via email, telephone or fax for further information (numbers and addresses are found inside the front cover of the manual).

**Figure 15:** QNX 4.XX: switch settings



**Figure 16:** QNX 4.XX: IRQ settings



**Note:** All DFlex ports are interrupting on channel A, IRQ 10.

The command line example shown below assumes that COM1 and COM2 are port 1 and port 2 on the DFflex adapter.

**Example:**

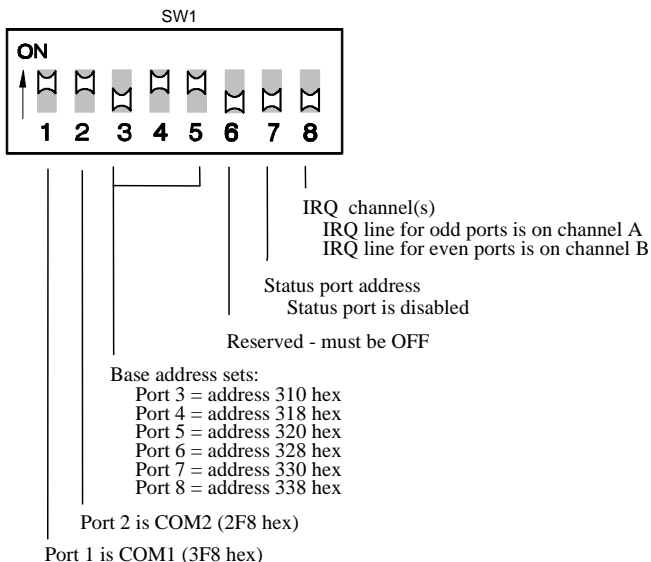
Dev.ser 3f8,4 2f8,3 310,4 318,3 320,4 328,3 330,4 338,3 &

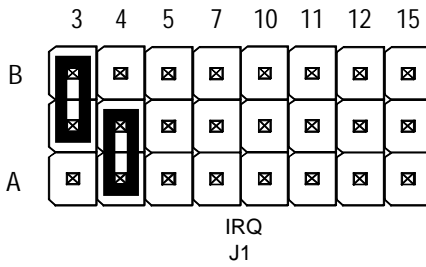
The above example configures a DFflex-8 adapter port 1 for COM1 at 3F8 hex, IRQ4; port 2 at COM2 at 2F8 hex, IRQ 3 and all other port addresses at 310, 318, 320, 328, 330, 338 hex respectively. All odd ports will interrupt on IRQ 4, channel A and all even ports on IRQ 3, channel B. Please refer to **Figures 17 and 18** for the DIP switch and jumper settings for your DFflex adapter and **Figures 1, 2, and 3** in **Chapter 1: Introduction** for the location of switch block SW1 and jumper block J1.

**Technical Tip**

You can run under DOS the DOS programs `porttest.exe` and `portfind.exe` to verify your settings and assure you have no hardware conflicts. You will find these programs on the **DFflex DOS Driver** diskette (p/n: DISK306).

**Figure 17:** QNX 4.XX: switch settings



**Figure 18:** *QNX 4.XX: IRQ settings*

**Note:** All DFlex odd ports are interrupting on channel A, IRQ 4 and all DFlex even ports are interrupting on channel B, IRQ 3.

**QNX 6.XX**

For information about installing the DFflex adapter for the QNX 6.XX operating system, please go to the **Download Zone** or the **Knowledge Database** in the **Support Center** on the Connect Tech website for product manuals, installation guides, device driver software and technical tips. If these sources do not provide you with the help you need please contact a Connect Tech Technical Support Representative via email, telephone or fax for further information (numbers and addresses are found inside the front cover of the manual).

## SCO Unix

This section describes how to setup a DFlex adapter for operation under SCO Unix.

### Configuration

#### Step 1

You can setup your DFlex adapter for many hardware configurations. Set the DIP switches on switch block SW1 and jumpers on jumper block J1 for your DFlex adapter and install it in your computer. See **Figures 1, 2, and 3 in Chapter 1: Introduction** for the location of switch block SW1 and jumper block J1.

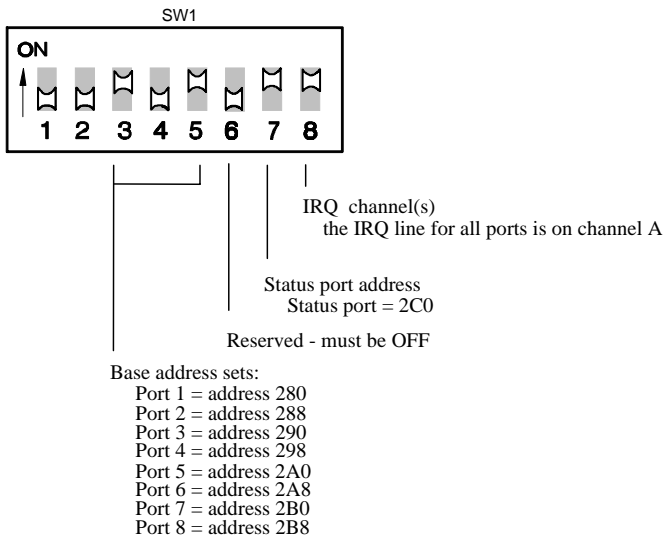
**Figures 19 and 20** show the switch settings and jumper settings of a DFlex-8 set for the following sample configuration:

starting I/O address: 280h  
interrupt request (IRQ) 10  
status port enabled (at address 2C0h)  
all interrupts are on A channel of the DFlex

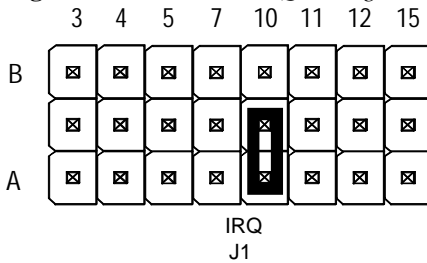
#### **Technical Tip**

1. You can run under DOS the DOS programs **porttest.exe** and **portfind.exe** to verify your settings and assure you have no hardware conflicts. You will find these programs on the **DFlex DOS Driver** diskette (p/n: DISK306).
2. If you did not receive a SCO Unix driver diskette or you require additional information, please go to the **Download Zone** or the **Knowledge Database** in the **Support Center** on the **Connect Tech** website for product manuals, installation guides, device driver software and technical tips. If these sources do not provide you with the help you need please contact a **Connect Tech Technical Support Representative** via email, telephone or fax for further information (numbers and addresses are found inside the front cover of the manual).

**Figure 19:** *SCO Unix: switch settings*



**Figure 20:** *SCO Unix: IRQ settings*



**Note:** All ports are interrupting on channel A, IRQ 10

**Step 2**

You now must make an entry for the DFlex adapter in the file `space.c`. This entry tells the operating system about the DFlex adapter:

1. Change to `/etc/conf/pack.d/sio` directory and backup the file `space.c`.
2. Open the file `space.c` with your editor. You will find listings for many different serial adapters so search the list until you find an entry for a Stargate adapter. The Stargate entries are essentially compatible with the DFlex adapter. This entry should look like the following:

```
{2,STARGATE,8,4,8,(sd)0x280,0x280+STAR_POLL,8,
MCRBIT3},/*AT-Stargate*/
```

We can describe the parameters for this entry as follows:

```
{[COM #],[Board type],[# of ports],[IRQ],
[Minor #],[Port address],[Status port address],
[Bus width],[Modem control register]}
[Device description]
```

Where:

[COM]

This parameter allows you to assign a COM to the serial adapter. There are four available COM assignments under SCO Unix.:

```
0 = COM1   1 = COM2
2 = COM3   3 = COM4
```

**Note:**

*COM refers to a serial board **and not a specific port**. There is no relation between COM1, COM2 under DOS and COM under SCO Unix*

[Board type]

The style of serial adapter. This tells the SCO Unix serial driver what to expect from the hardware.

[# of ports]

The number of ports found on the serial adapter.

[IRQ]	The IRQ setting for the adapter.
[Minor #]	Each COM has a different minor number.
	<p><b>Example:</b>  <i>COM1 0 is the minor number</i>  <i>COM2 8 is the minor number</i>  <i>COM3 16 is the minor number</i>  <i>COM4 24 is the minor number</i></p> <p><b>Note:</b>  <i>These numbers vary according to the values in your file</i>  <i>/usr/lib/mkdev/perms/SER</i></p>
[Port address]	Is the starting I/O address (hex) for the adapter
[Status port address]	Is the I/O address (hex) for the status port of the adapter
[Bus width]	
[Modem control register]	The location of the modem control register bit on the UART
[Device description]	A comment field used to describe the device

3. Make a copy of this entry and modify it to reflect the settings of your DFlex adapter.

**Example**

```
{2,STARGATE,8,10,16,(sd)0x280,0x280+STAR_POLL,
8,MCRBIT3},/*AT-DFlex-8*/
```

*This example entry reflects a base address setting of 280h and an IRQ setting of 10 for a DFlex-8 adapter.*

4. Insert the modified entry among the other COM3 entries in the space.c file
5. Save the file and exit.

**Step 3**

You now must modify the **SER** file to insure the proper alignment of the minor numbers.

1. Change the directory to the **/usr/lib/mkdev/perms** directory and backup the file **SER**.
2. Open the file **SER** with your editor. Find the section for the COM3 devices ( **/dev/tty3a,b,c...**), those lines should begin with **SER3**. This is the first area to modify. You will need to remove some of the comment lines (lines beginning with **#**) and align the minor numbers to be in sequence with minor numbers from **SER1** and **SER2**. When complete the **SER3** section should look like the following:

```
#
SER3 c666 bin/bin 1 /dev/tty3a 5/16
SER3 c666 bin/bin 1 /dev/tty3b 5/17
SER3 c666 bin/bin 1 /dev/tty3c 5/18
SER3 c666 bin/bin 1 /dev/tty3d 5/19
SER3 c666 bin/bin 1 /dev/tty3e 5/20
SER3 c666 bin/bin 1 /dev/tty3f 5/21
SER3 c666 bin/bin 1 /dev/tty3g 5/22
SER3 c666 bin/bin 1 /dev/tty3h 5/23
#
```

You will find further down in the `SER` file the modem device names. You must modify this section in a similar fashion to the above. When completed this section should look like:

```
#
SER3 c666 bin/bin 1 /dev/tty3A5/144
SER3 c666 bin/bin 1 /dev/tty3B5/145
SER3 c666 bin/bin 1 /dev/tty3C5/146
SER3 c666 bin/bin 1 /dev/tty3D5/147
SER3 c666 bin/bin 1 /dev/tty3E 5/148
SER3 c666 bin/bin 1 /dev/tty3F 5/149
SER3 c666 bin/bin 1 /dev/tty3G5/150
SER3 c666 bin/bin 1 /dev/tty3H5/151
#
```

**Note:**

1. *The changes to the `SER` file are usually not necessary when installing a DFlex-2 adapter.*
2. *If you were installing your DFlex as COM1 or COM2 then the default minor numbers are usually sufficient and don't require changing*

3. When you finish save the `SER` file and exit.

#### Step 4

You now must run `mkdev serial` which creates special device files to interface with the operating system's serial driver. When running `mkdev serial`, select the appropriate number of ports being installed (i.e., 2, 4, or 8 port DFlex board). You will find that `mkdev serial` prompts you with some options:

- i Select this to install a new board
- 1 Select this to install standard tty driver
- # Enter the number of ports you want to install
- # Enter the number for the COM (enter the COM number you wish to install - 3 for COM3 for the example above)
- ? Option(s) for various boards will be displayed. Select the DFlex board corresponding to the changes you made in the `space.c` file and make the following choices:
  - Enter the default baud rate, i.e. 9600
  - Enter m for 9600,n,8,1.

The system will now prompt you with a number of yes or no questions about rebuilding the kernel. Answer yes to all of these to build the kernel with the new DFlex settings. This will take about two minutes to complete.

### **Step 5**

With the DFlex installed you can reboot the system by typing:

```
sync;sync;reboot
```

If you still need to install the hardware you can shutdown the system by typing:

```
sync;sync;shutdown
```

or

```
sync;sync;haltsys
```

You should see the additional DFlex ports in the list of installed/found devices displayed at bootup. If you miss this message, you can find it in the file `/usr/adm/messages` by typing (this will print out the last 50 messages):

```
tail -50 /usr/adm/mess*
```

### **Other Configurations**

It is possible to run your DFlex board using I/O addresses and interrupts other than those listed above. In order to do this, it will be necessary to modify certain system files. Consult the "Release Notes" section of your operating system manuals or contact Connect Tech's Customer Support for more information.

**Technical Tips**

*If you experience difficulties installing your DFflex adapter try the following steps:*

- 1. Check to see if you have followed the above procedures closely.*
- 2. Check for conflicting devices in your system. It is possible that there is a conflict between the DFflex adapter and another board in the system. This could be an IRQ or I/O port conflict. Try using the `porttest.exe` and `portfind.exe` found on the **DFflex DOS Driver** diskette (p/n: DISK306) to find the hardware conflicts.*
- 3. If you use a system with a Plug and Play(PnP) BIOS or PCI bus, you might have to configure the CMOS setup for non-PnP devices like the DFflex adapter.*
- 4. If you need to remove/un-install the DFflex, you should use the `mkdev serial` utility and follow the options for `(r)` remove a board. If you decide that the DFflex adapter is not working due to a conflict, you should remove the board with `mkdev serial`, reboot and then run `mkdev serial` to install the DFflex at some alternate settings.*

**Solaris**

For information about installing the DFlex adapter for the Solaris operating system, please go to the **Download Zone** or the **Knowledge Database** in the **Support Center** on the Connect Tech website for product manuals, installation guides, device driver software and technical tips. If these sources do not provide you with the help you need please contact a Connect Tech Technical Support Representative via email, telephone or fax for further information (numbers and addresses are found inside the front cover of the manual).

**Windows 3.XX: DFlex-2/-2Fast as COM3 & COM4**

Windows 3.XX and its standard serial port driver **COMM.DRV** allow users to configure their computer systems with up to four serial ports as COM1, COM2, COM3 and COM4. Windows 3.XX and **COMM.DRV** require that each serial port have a different port address and IRQ. Most computer systems come with two standard serial ports configured as COM1 (port address 3F8 hex, IRQ 4) and COM2 (port address 2F8 hex, IRQ 3). In most cases you cannot configure these serial ports for other port addresses or IRQs.

The DFlex-2 and DFlex-2/Fast are ideal choices for adding two extra serial ports as COM3 and COM4 under Windows 3.XX. The DFlex-2 and DFlex-2/Fast are two port serial adapters with configurable I/O port addresses and IRQs. You can order them with 16450, 16550, 16650, or 16750 style UARTS for applications using the buffering capabilities of the chip's FIFO (recommended choice).

**Note:**

*There are third party serial drivers for Windows 3.XX that support more than four serial ports with shared interrupts. These drivers also support DFlex adapters. Please contact Connect Tech Customer Support for more information.*

**Technical Tip**

1. *You can run under DOS the DOS programs **porttest.exe** and **portfind.exe** to verify your settings and assure you have no hardware conflicts. You will find these programs on the **DFlex DOS Driver** diskette (p/n: DISK306).*
2. *If you did not receive a Windows driver diskette or you require additional information, please go to the **Download Zone** or the **Knowledge Database** in the **Support Center** on the **Connect Tech** website for product manuals, installation guides, device driver software and technical tips. If these sources do not provide you with the help you need please contact a **Connect Tech Technical Support Representative** via email, telephone or fax for further information (numbers and addresses are found inside the front cover of the manual).*

## Configuration

To enable COM3 and COM4 under Windows 3.XX you must modify the **AUTOEXEC.BAT**, **WIN.INI** and **SYSTEM.INI** files on your system. Refer to the following examples for appropriate modifications of these files.

### **Example 1**

Add the following statements to the **AUTOEXEC.BAT** file.

```
comset com3 280
comset com4 288
mode com3: 9600,n,8,1
mode com4: 9600,n,8,1
```

The **DFlex** program **COMSET** will set **COM3** to base address 280 hex and **COM4** to base address 288 hex. The **MODE** command will configure **COM3** and **COM4** to standard settings (baud rate, parity, data bits, stop bits) in this case 9600 baud, no parity, 8 data bits, 1 stop bit. Please make certain that the **DFlex** program **COMSET** is in a directory in your **PATH** statement.

### **Example 2**

The following statements under the **[ports]** section of the **WIN.INI** file informs Windows 3.XX of the default settings (baud rate, parity, data bits, stop bits) for **COM3** and **COM4**. If these statements are not present please add them under the **[ports]** section of the **WIN.INI** file.

```
com3:=9600,n,8,x
com4:=9600,n,8,x
```

### **Example 3**

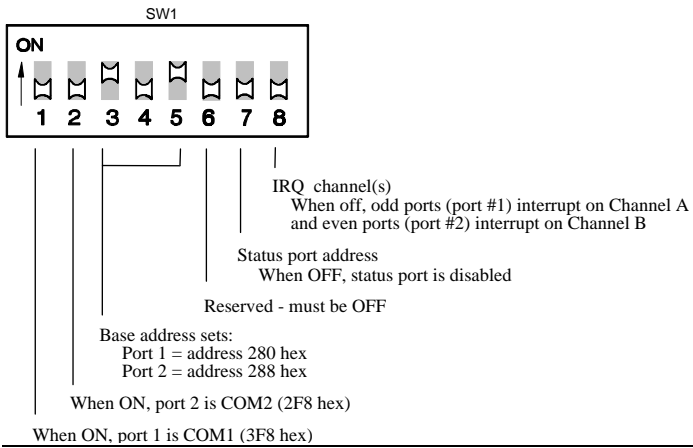
Add the following statements under the **[386Enh]** section of the Windows 3.XX **SYSTEM.INI** file. This informs Windows 3.XX that **COM3** is at **IRQ 10**, base address 280 hex and **COM4** is at **IRQ 11**, base address 288 hex.

```
COM3Irq=10
COM3Base=0280
COM4Irq=11
COM4Base=0288
```

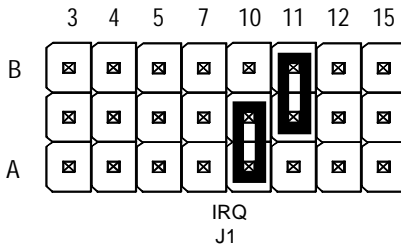
**Figure 21** and **Figure 22** below show the DFflex-2 and DFflex-2/Fast DIP switch and jumper settings for the preceding examples. Please refer to **Figure 3** in **Chapter 1: Introduction** for the location of switch block SW1 and jumper J1.

**Technical Tip**  
 You can run under DOS the DOS programs `porttest.exe` and `portfind.exe` to verify your settings and ensure you have no hardware conflicts. You will find these programs on the **DFflex DOS Driver** diskette (p/n: DISK306).

**Figure 21: Windows 3.XX: switch settings**



**Figure 22: Windows 3.XX: IRQ settings**



**Note:** Port 1 (COM3) interrupts on Channel A, IRQ 10 and port 2 (COM4) interrupts on Channel B, IRQ 11.

## Windows 95

Windows 95 allows you to add up to 128 serial ports to your computer system. The Windows 95 standard serial port driver supports IRQ sharing (if the hardware supports it) and the FIFO buffering capabilities of the 16550 UARTs.

**Note:**

*A DFlex adapter with 16650 and 16750 UARTs offers on chip 32 byte and 64 byte transmit and receive FIFO buffers respectively. The standard Windows 95 serial driver will recognize up to a 32 byte receive buffer but only a 16 byte transmit buffer. See the **DFlex Enhanced Driver** section for information on enhanced support for the 16650 and 16750 UARTs under Windows 95.*

**Technical Tip**

1. *You can run under DOS the DOS programs **porttest.exe** and **portfind.exe** to verify your settings and assure you have no hardware conflicts. You will find these programs on the **DFlex DOS Driver** diskette (p/n: DISK306).*
2. *If you did not receive a Windows driver diskette or you require additional information, please go to the **Download Zone** or the **Knowledge Database** in the **Support Center** on the **Connect Tech** website for product manuals, installation guides, device driver software and technical tips. If these sources do not provide you with the help you need please contact a **Connect Tech Technical Support Representative** via email, telephone or fax for further information (numbers and addresses are found inside the front cover of the manual).*

You can configure a single DFlex serial adapter to share one IRQ allowing that DFlex's serial ports to share one interrupt. You can add as many DFlex adapters as you have ISA slots for, remembering that each board will need a unique range of I/O port addresses and IRQ's.

**DFlex Enhanced Driver**

The Connect Tech enhanced serial port driver extends the functionality of the standard Windows 95 Device driver to include support for new high performance UARTs.

New 16650 and 16750 compatible UART chips provide larger FIFO buffers that the standard Windows 95 serial driver does not support. The Enhanced Driver supports both the older 16450, 16550 and the newer 16650 and 16750 UARTs.

The following table shows the maximum sizes of the FIFOs on these UARTs:

<i>CHIP</i>	<i>FIFO SIZE (bytes)</i>
16450	0
16550	16
16650	32
16750	64

The Enhanced Driver supports DFlex serial ports and standard non-intelligent serial ports.

### Installation

The following instructions outline how to install the DFlex Enhanced Driver on a previously uninstalled Connect Tech DFlex port.

1. If the driver is on disk, insert the disk into the desired drive. If you have downloaded the driver in ZIP format, unzip the files to a temporary directory.
2. From the **CONTROL PANEL**, select the **ADD NEW HARDWARE** icon and hit **NEXT**.
3. When the program asks **DO YOU WANT WINDOWS TO SEARCH FOR NEW HARDWARE?** select **NO** and hit **NEXT**.
4. You will be presented with a list of devices that can be installed. Pick **MULTI-FUNCTION ADAPTERS** from the list and hit **NEXT**.
5. A list of supported manufacturers and models will be listed. Hit the **HAVE DISK** button.
6. Select the directory or drive that the drivers are contained on and hit **OK**.
7. Select **CONNECT TECH INC.** types from the manufacturer list and the appropriate DFlex board from the model type and hit **NEXT**.
8. A range of IO port settings and an IRQ will display. In most cases the settings displayed are the best settings to use. **Make sure these settings match the ones used by your DFlex adapter.** You cannot change the settings at this point. You will have to change them after the installation is complete. So hit **NEXT** for now.
9. Hit **FINISH** and it will install the new serial driver. The system will ask if you want to shut down the computer. Hit **NO** if the settings the computer chose for the board were incorrect and go to the **DEVICE MANAGER** to change the settings (IO base port of 280 and IRQ 10 are the defaults).
10. If the settings were correct hit **YES** and your installation is done. After the computer has restarted it will install each of the DFlex ports into the **PORTS** section of the **DEVICE MANAGER**. Follow the directions listed under the **UART/FIFO Configuration** section in order to set the DFlex's UART type and FIFO levels for Windows 95.

**UART/FIFO Configuration**

To configure the DFlex Enhanced Driver for the appropriate UART type please follow these steps:

1. From the **CONTROL PANEL** double click on the **SYSTEM** icon.
2. The **SYSTEM PROPERTIES** dialog box will pop up and click on the **DEVICE MANAGER** tab.
3. Double click the **PORTS (COM & LPT)** section.
4. Double click the COM port you want to change. This will bring up a **PROPERTIES** page.
5. Click on the **ENHANCED PORT SETTINGS** tab.
6. Click on the **ADVANCED** button. The **ADVANCED PORT SETTINGS** dialog box will pop up.
7. If you do not have a 16550, 16650 or 16750 compatible UART make sure the **USE FIFO BUFFERS** **is not checked**. Otherwise check this box and select the appropriate type from the 16550, 16650 or 16750 choices. When you select **USE FIFO BUFFERS** you enable the two sliders labeled **RECEIVE BUFFER** and **TRANSMIT BUFFER**. Moving a slider to the right, enables more buffering resulting in higher speeds and lower load on the system. However high buffer levels can cause connection problems. Usually it is best to set the **RECEIVE BUFFER** at one notch below the highest setting and the **TRANSMIT BUFFER** at the highest setting. Then click **OK**.

**Note:**

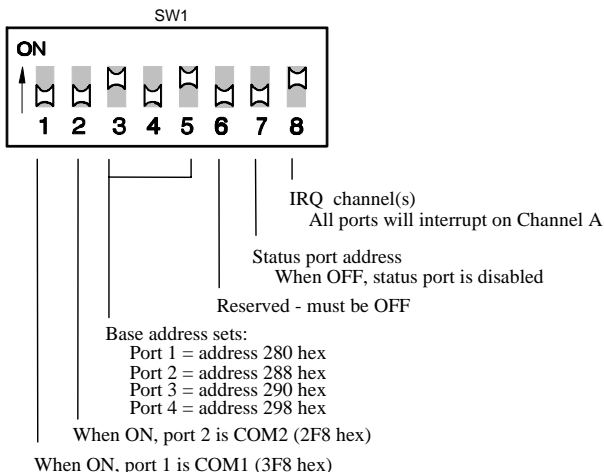
*If you select the wrong type of UART, the DFlex adapter will run in 16450 mode (no FIFO) when you access the port. If you do not know what type of UART you have try using the PortFind utility available from Connect Tech's FTP site ([ftp.connecttech.com](ftp://ftp.connecttech.com)).*

## Configuration

The following installation assumes that your computer system comes with two standard serial ports, COM1 (at 3F8, IRQ 4); COM2 (at 2F8, IRQ 3) and that you are installing a DFlex-4 or DFlex-4/Fast adapter.

1. You need to choose a range of I/O addresses for your DFlex adapter that will not conflict with any other addresses. A good range to choose is the default settings, 280h, 288h, 290h and 298h. **Figure 23** shows the example switch settings. Please refer to **Figures 1, 2, or 3 in Chapter 1: Introduction** for the location of the DIP switch block SW1

**Figure 23:** Windows 95: switch settings



2. Choose an IRQ for your DFlex. It is possible to have the even ports on one IRQ and the odd ports on a different IRQ, but we recommend having all ports on one IRQ. Good choices of IRQ's are 5, 10, 11, 12 and 15. The two serial ports that come with your system usually use IRQ 4, 3 and LPT1 is usually IRQ 7. Please refer to the Table showing typical IRQ usage in **Chapter 2: Hardware Installation**. For our example we will choose IRQ 10. **Figure 24** shows the example IRQ setting. Please refer to **Figures 1, 2, or 3** in **Chapter 1: Introduction** for the location of the jumper block J1.

**Figure 24:** Windows 95: IRQ settings

	3	4	5	7	10	11	12	15
B	<input checked="" type="checkbox"/>	<input checked="" type="checkbox"/>	<input checked="" type="checkbox"/>	<input checked="" type="checkbox"/>	<input checked="" type="checkbox"/>	<input checked="" type="checkbox"/>	<input checked="" type="checkbox"/>	<input checked="" type="checkbox"/>
	<input checked="" type="checkbox"/>	<input checked="" type="checkbox"/>	<input checked="" type="checkbox"/>	<input checked="" type="checkbox"/>	<input checked="" type="checkbox"/>	<input checked="" type="checkbox"/>	<input checked="" type="checkbox"/>	<input checked="" type="checkbox"/>
A	<input checked="" type="checkbox"/>	<input checked="" type="checkbox"/>	<input checked="" type="checkbox"/>	<input checked="" type="checkbox"/>	<input checked="" type="checkbox"/>	<input checked="" type="checkbox"/>	<input checked="" type="checkbox"/>	<input checked="" type="checkbox"/>

IRQ  
J1

**Note**

All DFlex ports interrupt on Channel A, IRQ 10.

**Technical Tip**

You can run under DOS, the DOS programs `porttest.exe` and `portfind.exe`, to verify your settings and assure you have no hardware conflicts. You will find these programs on the **DFlex DOS Driver** diskette (p/n: DISK306)

3. You can now install the DFlex in your system and start up Windows 95. Once Windows-95 has started, go to the MY COMPUTER icon and double click.
4. Now click on CONTROL PANEL and then click on ADD NEW HARDWARE. The ADD NEW HARDWARE WIZARD will appear. Click NEXT. It will prompt you for AUTODETECTION, select NO and click NEXT. A list of hardware devices will appear, select PORTS(COM & LPT) and click NEXT. Now select COMMUNICATIONS PORT and click NEXT.

5. A window will now appear with the headings **RESOURCE TYPE** and **SETTING**. The settings shown are probably wrong. Do not worry we will change them later. Click **NEXT**. Another window will appear. Click on **FINISH**.
6. You will now see a **SYSTEMS SETTINGS CHANGE** window prompting you to reboot the machine and since the settings are wrong click **NO**. If you have more DFlex serial ports to add you should repeat steps 4 - 6 until you have enough additional new COM ports installed.
7. You now go to the **SYSTEM PROPERTIES** menu by clicking on the **SYSTEM** icon in the **CONTROL PANEL**. Click on the **DEVICE MANAGER** tab. A list of devices will appear. Click on **PORTS (COM & LPT)** and it will expand showing all the ports. Choose the new COM port just created. Click on **PROPERTIES** (double clicking the COM port will also bring up **PROPERTIES**). This is where we tell Windows 95 about the settings for the DFlex adapter.
8. You should now have a **COMMUNICATIONS PORT (COM??) PROPERTIES** window. Click on the **RESOURCES** tab and you should see the current settings for this port. These are the settings we want to change. There are three steps to follow:
  - 8.1. First select **BASIC CONFIGURATION 8** in the **SETTINGS BASED ON** area.
  - 8.2. We now need to change the **INPUT/OUTPUT RANGE** under the **RESOURCE TYPE** heading, so double click there. A new window will appear and this is where you can enter the DFlex I/O port address (Example 200-207) or use the UP/DOWN arrows of the dialog box to find one to select. Click **OK**.
  - 8.3. We now need to change the **INTERRUPT REQUEST** under the **RESOURCE TYPE** heading, so double click there. A new window will appear and you can now enter the IRQ of you DFlex card (example IRQ 10) or use the UP/DOWN arrows of the dialog box to find one to select. Click **OK**. You should now be back at the **COMMUNICATIONS PORT (COM??) PROPERTIES** window, so click **OK**.

9. The **SYSTEMS SETTINGS CHANGE** window will appear. Click **NO** and repeat Steps 7 through 9 until you have setup all your DFlex serial ports. Click **YES** when you have set up all your DFlex ports. Your system will now reboot with your DFlex serial ports installed.

***Technical tips***

1. A test program is available on the **DFlex DOS Driver** diskette (p/n: DISK306). It is a Windows 95 and Windows NT compatible test program. For more information please check the file **sertest.zip**. This program requires a loopback connector (see the file **readme.pts** on the **DFlex DOS Driver** diskette for loopback wiring instructions)
2. There is no direct support for RS-485 half duplex communications within the Windows 95 serial driver.
3. The RS-422 interface will work in point to point, full duplex and multi-drop communications.
4. The 20mA Current Loop interface is functional.
5. The standard Windows 95 serial driver supports standard 16450 and 16550 UARTs.
6. When installing the additional serial ports, Windows 95 will sometimes skip to the label COM5.
7. Some Windows 95, Windows NT and Windows 3.XX applications can only access up to COM9. These applications include:

*Modem Setup Wizard  
Printer Setup Wizard  
Visual Basic*

*For developers a work around is available under Microsoft C++. You can label serial ports as COM1, COM2..., etc., for serial ports 1 to 9. An alternative method is to label them as \\.\COM1, \\.\COM2..., etc. You can access all serial ports under Windows 95 and Windows NT using this alternative method. See your Microsoft C++ documentation for more information.*

## Windows NT

Windows NT allows you to add up to 255 serial ports to your computer system. The Windows NT serial port driver supports IRQ sharing (if the hardware supports it) and the FIFO buffering capabilities of the 16550.

**Note:**

*A DFlex adapter with 16650 UARTs offers on chip 32 byte transmit and receive FIFO buffers. The standard Windows NT serial driver will recognize the 32 byte receive buffer but only a 16 byte transmit buffer. See the **DFlex Enhanced Driver** section for information on enhanced support for the 16650 UART under Windows NT*

**Technical Tip**

1. *You can run under DOS the DOS programs **porttest.exe** and **portfind.exe** to verify your settings and assure you have no hardware conflicts. You will find these programs on the **DFlex DOS Driver** diskette (p/n: DISK306).*
2. *If you did not receive a Windows driver diskette or you require additional information, please go to the **Download Zone** or the **Knowledge Database** in the **Support Center** on the **Connect Tech** website for product manuals, installation guides, device driver software and technical tips. If these sources do not provide you with the help you need please contact a **Connect Tech Technical Support Representative** via email, telephone or fax for further information (numbers and addresses are found inside the front cover of the manual).*

You can configure a single DFlex serial adapter to share one IRQ allowing that DFlex's serial ports to share one interrupt. You can add as many DFlex adapters as you have ISA slots for, remembering that each board will need a unique range of I/O port addresses and IRQ's.

## DFlex Enhanced Driver

The DFlex Enhanced Driver for Windows NT extends the functionality of the standard Windows NT device driver to include support for new high performance UARTs.

The standard Windows NT serial driver offers support for 16450 and 16550 UARTS, but does not support the larger FIFO buffers of the 16650 and 16750 UARTs. The following table shows the maximum sizes of the FIFOs on the various UARTs:

<i>CHIP</i>	<i>FIFO SIZE (bytes)</i>
16450	0
16550	16
16650	32
16750	64

The DFlex Enhanced Driver provides support for the 16650 UARTs but does not currently support the advance capabilities of the 16750 UART.

**Note:**

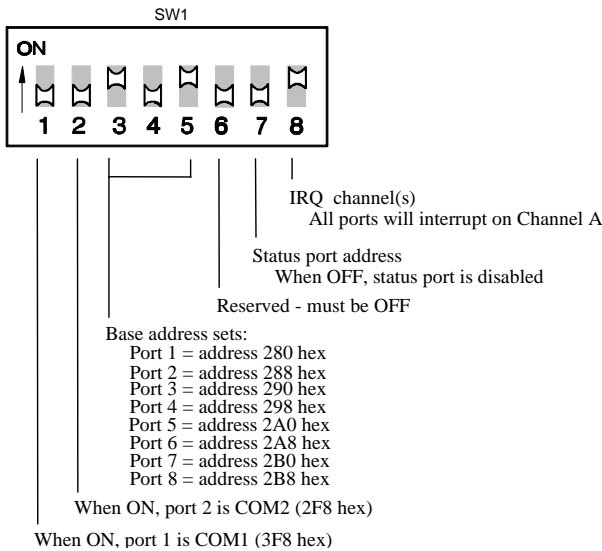
*If you have purchased a DFlex adapter that has 16450 or 16550 UARTs use the Windows NT standard serial driver. If you have purchased a DFlex adapter with 16650 UARTs and you wish to use the increased FIFO buffers please install the DFlex Enhanced Driver as follows:*

- 1. Copy the files **serial.z** and **DflexSetup.exe** to a permanent location on your hard disk.*
- 2. Double click **DflexSetup.exe** and select **INSTALL DRIVER**. **DflexSetup.exe** will backup the existing Windows NT **serial.sys** and replace it with the Connect Tech **serial.sys** in the **C:\WINNT\SYSTEM32\DRIVERS** directory.*

### Configuration

The following installation assumes that your computer system comes with two standard serial ports, COM1 (at 3F8, IRQ 4); COM2 (at 2F8, IRQ 3) and that you are installing a DFlex-8 adapter.

- 1.** You need to choose a range of I/O addresses for your DFlex adapter that will not conflict with any other addresses. A good range to choose is the default settings, 280h, 288h, 290h, 298h, 2A0h, 2A8h, 2B0h, and 2B8h. **Figure 25** shows the example switch settings. Please refer to **Figures 1, 2, or 3** in **Chapter 1: Introduction** for the location of the DIP switch block SW1.

**Figure 25:** *Windows NT: switch settings*

2. Choose an IRQ for your DFlex. It is possible to have the even ports on one IRQ and the odd ports on a different IRQ, but we recommend having all ports on one IRQ. Good choices of IRQ's are 5, 10, 11, 12 and 15. The two serial ports that come with your system usually use IRQ 4, 3 and LPT1 is usually IRQ 7. Please refer to the Table showing typical IRQ usage in **Chapter 2: Hardware Installation**. For our example we will choose IRQ 10. **Figure 26** shows the example IRQ setting. Please refer to **Figures 1, 2, or 3** in **Chapter 1: Introduction** for the location of the jumper block J1.

**Figure 26:** *Windows NT: IRQ settings*

	3	4	5	7	10	11	12	15
B	<input checked="" type="checkbox"/>	<input checked="" type="checkbox"/>	<input checked="" type="checkbox"/>	<input checked="" type="checkbox"/>	<input checked="" type="checkbox"/>	<input checked="" type="checkbox"/>	<input checked="" type="checkbox"/>	<input checked="" type="checkbox"/>
	<input checked="" type="checkbox"/>	<input checked="" type="checkbox"/>	<input checked="" type="checkbox"/>	<input checked="" type="checkbox"/>	<input checked="" type="checkbox"/>	<input checked="" type="checkbox"/>	<input checked="" type="checkbox"/>	<input checked="" type="checkbox"/>
A	<input checked="" type="checkbox"/>	<input checked="" type="checkbox"/>	<input checked="" type="checkbox"/>	<input checked="" type="checkbox"/>	<input checked="" type="checkbox"/>	<input checked="" type="checkbox"/>	<input checked="" type="checkbox"/>	<input checked="" type="checkbox"/>

IRQ  
J1

**Note**

All DFlex ports interrupt on Channel A, IRQ 10.

**Technical Tip**

You can run under DOS the DOS programs `porttest.exe` and `portfind.exe` to verify your settings and assure you have no hardware conflicts. You will find these programs on the **DFlex DOS Driver** diskette (p/n: DISK306)

3. You can now install the DFlex in your system and start up Windows NT. Once Windows NT has started, logon as administrator (installation specific account).
4. For Windows NT 3.51 open the **MAIN PROGRAM** group. For Windows NT 4.0 select the **START** menu and **SETTINGS**.
5. Click on the **CONTROL PANEL** group.
6. Click on the **PORTS** group.
7. Click the **ADD** button.
8. Set the desired **COM PORT NUMBER** if necessary. This number will default to next available **COM PORT NUMBER**, in this case 3 since the system has standard serial ports at COM1 and COM2.
9. Set the **BASE I/O PORT ADDRESS** by entering the port address for the DFlex's first serial port, in this case 280.
10. Set the **INTERRUPT REQUEST LINE (IRO)** for your DFlex adapter by selecting a number from the list, in this case 10.
11. Select the **FIFO ENABLED** option.

12. Click the **DONE** button **but do not select** the **REBOOT** option yet.
13. Repeat steps 7 through 12 for the remaining DFlex serial ports, each time specifying the appropriate I/O port address (i.e., 288, 290, 298, etc.) and the same IRQ (i.e., 10).
14. Now you must edit the registry database in order to inform the serial driver that all the DFlex serial ports will share the same IRQ. There are two methods for doing this; a simple **Method A** and a more complex, but more powerful **Method B**.

#### **Method A**

This series of steps involves editing the registry database to inform the WindowsNT serial driver that all the DFlex ports will share the same hardware Interrupt.

- 14.1. For Windows NT v.3.51 you click on the **WINDOWS NT DIAGNOSTIC** icon in the **ADMINISTRATIVE TOOLS** group and then select **TOOLS**, then **REGISTRY**.
- 14.2. For Windows NT 4.0 select **START**, then **RUN** and then enter **REGEDT32** and hit the **ENTER** key. This will bring up the Windows NT Registry Editor.
- 14.3. Make sure you are editing the **HKEY\_LOCAL\_MACHINE** registry.
- 14.4. Select the **SYSTEM** folder.
- 14.5. Select the **CURRENT CONTROL SET** folder.
- 14.6. Select the **SERVICES** folder.
- 14.7. Select the **SERIAL** folder.
- 14.8. On the right side you will see some information. Double click the **PERMIT SHARE** line and a dialogue box opens. You need to alter this item as the default is sharing **OFF** and you must set sharing **ON**. You then can change the setting to 1 (sets sharing **ON**).
- 14.9. The system will save the changes when you exit the registry editor.

**Method B**

This method is more complex than **Method A** and involves writing information regarding the DFlex status port to the Windows NT registry. Since this method will enable your DFlex adapter's status port, you will attain better system performance in the way of less CPU usage.

**Note:**

*You will need to know the I/O address of the your DFlex adapter's status port and make sure that DIP switch 7 on the DFlex's switchblock SW1 is set to ON*

- 14.10.** For Windows NT v.3.51 you click on the **WINDOWS NT DIAGNOSTIC** icon in the **ADMINISTRATIVE TOOLS** group and then select **TOOLS**, then **REGISTRY**.
- 14.11.** For Windows NT 4.0 select **START**, then **RUN** and then enter **REGEDT32** and hit the **ENTER** key. This will bring up the Windows NT Registry Editor.
- 14.12.** Make sure you are editing the **HKEY\_LOCAL\_MACHINE** registry.
- 14.13.** Select the **SYSTEM** folder.
- 14.14.** Select the **CURRENT CONTROL SET** folder.
- 14.15.** Select the **SERVICES** folder.
- 14.16.** Select the **SERIAL** folder.
- 14.17.** Select the **PARAMETERS** folder.
- 14.18.** You will need to add two new values: an **InterruptStatus** value and a **PortIndex** value for each **SERIAL** key associated with your DFlex ports (**SERIAL110000**, **SERIAL110001**, **SERIAL110002**, etc.).

- 14.19.** Choose **EDIT**, then **ADD VALUE**, and enter in the following values **EXACTLY** as below.

**Value Name:** InterruptStatus  
**Data Type:** REG\_DWORD  
**Value:** 2C0  
(Highlight Hex format Check Box)

**Note:**

1. For our example of Base I/O address 280, the DFlex status port is at I/O address 2C0.
2. The **Value** is the address of the status port corresponding to I/O address range set on the DFlex adapter. All DFlex ports on a single board will have the same status port address, so each key **Serial10000**, **Serial10001** up to **Serial1000n** will have the same value.

Once again choose **EDIT**, then **ADD VALUE**, and enter in the following values **EXACTLY** as below.

**Value name:** PortIndex  
**Data Type:** REG\_DWORD  
**Value:** 1

**Note:**

Each key **Serial10000**, **Serial10001** up to **Serial1000n** will get a unique entry for its **Value**. You will enter 1 for DFlex port one, 2 for port two, etc.

- 14.20.** Exit the Registry Editor and the system automatically saves the new values.
- 15.** You can now reboot your system and your Windows NT applications can access all the DFlex serial ports.

**Technical tips**


1. You can test the additional serial ports with a program like Terminal or HyperTerminal.
2. A test program is available on the **DFlex DOS Driver** diskette (p/n: DISK306). It is a Windows 95 and Windows NT compatible test program. For more information please check the file **sertest.zip**. This program requires a loopback connector (see the file **readme.pts** on the **DFlex DOS Driver** diskette for loopback wiring instructions)
3. There is no direct support for RS-485 half duplex communications within the Windows NT serial driver.
4. The RS-422 interface will work in point to point, full duplex and multi-drop communications.
5. The 20mA Current Loop interface is functional.
6. The standard Windows NT serial driver supports standard 16450 and 16550 UARTs.
7. Some Windows 95, Windows NT and Windows 3.XX applications can only access up to COM9. These applications include:

Modem Setup Wizard  
Printer Setup Wizard  
Visual Basic  
Terminal

For developers a work around is available under Microsoft C++. You can label serial ports as COM1, COM2..., etc., for serial ports 1 to 9. An alternative method is to label them as \\.\COM1, \\.\COM2..., etc. You can access all serial ports under Windows NT and Windows NT using this alternative method. See your Microsoft C++ documentation for more information.

# Chapter 4: Appendices

---

- Appendix A: Specifications..... 4-1
  - Operating Environment ..... 4-1
  - Power Requirements ..... 4-1
  - PC Bus Interface ..... 4-2
  - Communications ..... 4-2
  - Control Signals ..... 4-2
  - Dimensions ..... 4-2
  - Connectors/Interface..... 4-2
  - Certification ..... 4-3
    - FCC ..... 4-3
    - DOC/IC ..... 4-3
    -  ..... 4-3
    - General ..... 4-4
  
- Appendix B: Connectors/Pinouts ..... 4-5
  - Cable Connector Pinouts ..... 4-5
  - Connector Box/Pinouts ..... 4-9
  - SLIM Pinouts ..... 4-11
  
- Appendix C: Factory Settings ..... 4-13
  - DFlex-2; DFlex-2/Fast..... 4-13
    - I/O Port Address Setting ..... 4-13
    - IRQ Setting..... 4-14
  - DFlex-4; DFlex-4/Fast..... 4-15
    - I/O Port Address Setting ..... 4-15
    - IRQ Setting..... 4-16
  - DFlex-8 ..... 4-17
    - I/O Port Address Setting ..... 4-17
    - IRQ Setting..... 4-18
  
- Appendix D: SLIM Insertion/Removal ..... 4-19
  - SLIM insertion ..... 4-19
  - SLIM removal ..... 4-20
  
- Appendix E: RS-232 Option ..... 4-21
  - RS-232/Fast SLIM..... 4-23
  - Installation ..... 4-23
  
- Appendix F: RS-485/422 Option ..... 4-25
  - RS-485/422 SLIM..... 4-26
  - Installation ..... 4-28
  - RS-485/422 Cable Wiring ..... 4-30

Appendix G: RS-423 Option.....	4-33
Installation .....	4-35
RS-423 Cable Wiring.....	4-37
Appendix H: 20mA Current Loop Option .....	4-39
20mA Current Loop SLIM .....	4-39
Installation .....	4-42
Current Loop Cable Wiring .....	4-44

## Appendix A: Specifications

### Operating Environment

- Storage temperature: -60 ° C to 100 ° C
- Operating temperature: 5 ° C to 65 ° C
- Relative humidity: 5 - 90% no condensing
- Air movement: no requirement
- Altitude: 15,000 feet (5000 metres)

### Power Requirements

- *DFlex-8 (no Serial Line Interface Module)*  
+5 VDC +-5% @ 1.3 amps (max.)
- *DFlex-4; DFlex-4/Fast (no Serial Line Interface Module)*  
+5 VDC +-5% @ 0.9 amps (max.)
- *DFlex-2; DFlex-2/Fast (no Serial Line Interface Module)*  
+5 VDC +-5% @ 0.7 amps (max.)
- *RS-232 SLIM (no load)*  
+5 VDC +/- 5% @ 30 mA. typ.  
+12 VDC +/- 5% @ 1 mA. typ.
- *RS-232/Fast SLIM (no load)*  
+5 VDC +/- 5% @ 30 mA. typ.  
+12 VDC +/- 10% @ 38 mA. typ.  
-12 VDC +/- 10% @ 36 mA. typ.
- *RS-485/422 SLIM (no load)*  
+5 VDC +/- 5% @ 120 mA. typ.
- *RS-423 SLIM (no load)*  
+5 VDC +/- 5% @ 70 mA. typ.  
+12 VDC +/- 10% @ 26 mA. typ.  
-12 VDC +/- 10% @ 26 mA. typ.
- *20mA Current loop SLIM (no load)*  
+5 VDC +/- 5% @ 30 mA. typ.  
+12 VDC +/- 5% @ 4 mA. typ.



## Certification

**DFlex-2; DFlex-2/Fast**

**DFlex-4; DFlex-4/Fast**

**DFlex-8**

### FCC

This equipment complies with the requirements in Part 15 of FCC Rules for a Class A computing device. Operation of this equipment in a residential area may cause unacceptable interference to radio and TV reception requiring the operator to take whatever steps are necessary to correct the interference.

### DOC/IC

This Class A digital apparatus complies with Canadian ICES-003.

Cet appareil numérique de la classe A est conforme à la norme NMB-003 du Canada.



Connect Tech Inc. declares that the product(s) covered by the contents of this manual have been tested and found compliant with the below listed standards as required by the Electromagnetic Compatibility (EMC) Directive for General Immunity Compliance, EN 50 0082.1:1997

EN 55022 Conducted and Radiated emissions

EN 61000-4-2 Electrostatic Discharge

EN 61000-4-3 Radiated Immunity

EN 61000-4-4 Electrical Fast Transients

A handwritten signature in black ink, appearing to read 'Rod Doré', written in a cursive style.

Rod Doré  
Manager of Engineering

A handwritten signature in black ink, appearing to read 'David Worthen', written in a cursive style.

David Worthen, P.Eng  
President

**General**

The above agency conformances were met by independent laboratory testing of Connect Tech Inc. product(s) with shielded cables, with metal hoods, attached to either the terminating connectors or cable assemblies supplied with the product(s).

**Failure to follow good EMC/EMI compliant cabling practices may produce more emissions or less immunity than were obtained in laboratory measurements.**

Operation of this equipment in a residential area may cause unacceptable interference to radio a TV reception, requiring the user to take whatever steps necessary to correct the interference.

## Appendix B: Connectors/Pinouts

Appendix B outlines the pinouts for the following:

- DFlex-2/-4/-8; DFlex-2/-4/Fast cable connector pinouts
- DFlex external connector box pinouts
- SLIM pinouts

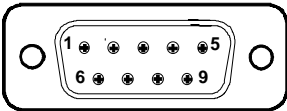
### Cable Connector Pinouts

Tables 7, 8, and 9 show the pinouts for the DFlex-2/-4/-8 and DFlex-2/-4/Fast cable connectors

**Table 7: DB-9 pinouts - DFlex**

Pin No.	RS-232 Signal	RS-485 Signal	RS-423 Signal	Current Loop Signal
1	DCD	RxD B(+)	RxD(+)	RxD(-)
2	RxD	TxD B(+)	TxD Ref	TxD(+)
3	TxD	TxD A(-)	TxD(-)	TxD Source
4	DTR	RxD A(-)	RxD(-)	TxD Return
5	SG	SR	SR	SG
6	Reserved	CTS A(-)	CTS(-)	RxD Return
7	RTS	RTS A(-)	RTS(-)	TxD(-)
8	CTS	RTS B(+)	RTS Ref	RxD(+)
9	Reserved	CTS B(+)	CTS(+)	RxD Source

Male DB-9 Connector



#### **Technical Tip:**

*Please ensure that you terminate the DCD or CTS signals if your application does not use them. The common way to do this is to connect DCD to DTR and/or to connect CTS to RTS. Failure to do so may result in a loss of a performance on your DFlex adapter.*

**Table 8:** DB-37 pinouts - DFlex-4; DFlex-4/Fast

Pin No.	SLIM/Pin No.	Port No.	RS-232 Signal	RS-485 Signal	RS-423 Signal	Current Loop Signal
1	SG	1	SG	SR	SR	SG
2	1/7	1	DTR	RxD A(-)	RxD A(-)	TxD Return
3	1/3	1	TxD	TxD A(-)	TxD (-)	TxD Source
4	1/5	1	RxD	TxD B(+)	TxD Ref	TxD(+)
5	1/9	1	DCD	RxD B(+)	RxD B(+)	RxD(-)
6			unused	unused	unused	unused
7	2/8	3		CTS B(+)	CTS B(+)	RxD Source
8	2/4	3	CTS	RTS B(+)	RTS Ref	RxD(+)
9	2/2	3	RTS	RTS A(-)	RTS (-)	TxD(-)
10	2/6	3		CTS A(-)	CTS A(-)	RxD Return
11	2/16	4		CTS B(+)	CTS B(+)	RxD Source
12	2/12	4	CTS	RTS B(+)	RTS Ref	RxD(+)
13	2/10	4	RTS	RTS A(-)	RTS (-)	TxD(-)
14	2/14	4		CTS A(-)	CTS A(-)	RxD Return
15	SG	2	SG	SR	SR	SG
16	1/15	2	DTR	RxD A(-)	RxD A(-)	TxD Return
17	1/11	2	TxD	TxD A(-)	TxD (-)	TxD Source
18	1/13	2	RxD	TxD B(+)	TxD Ref	TxD(+)
19	1/17	2	DCD	RxD B(+)	RxD B(+)	RxD(-)
20	1/8	1		CTS B(+)	CTS B(+)	RxD Source
21	1/4	1	CTS	RTS B(+)	RTS Ref	RxD(+)
22	1/2	1	RTS	RTS A(-)	RTS (-)	TxD(-)
23	1/6	1		CTS A(-)	CTS A(-)	RxD Return
24	SG	3	SG	SR	SR	SG
25	2/7	3	DTR	RxD A(-)	RxD A(-)	TxD Return
26	2/3	3	TxD	TxD A(-)	TxD (-)	TxD Source
27	2/5	3	RxD	TxD B(+)	TxD Ref	TxD(+)
28	2/9	3	DCD	RxD B(+)	RxD B(+)	RxD(-)
29	SG	4	SG	SR	SR	SG
30	2/15	4	DTR	RxD A(-)	RxD A(-)	TxD Return
31	2/11	4	TxD	TxD A(-)	TxD A(-)	TxD Source
32	2/13	4	RxD	TxD B(+)	TxD Ref	TxD(+)
33	2/17	4	DCD	RxD B(+)	RxD B(+)	RxD(-)
34	1/16	2		CTS B(+)	CTS B(+)	RxD Source
35	1/12	2	CTS	RTS B(+)	RTS Ref	RxD(+)
36	1/10	2	RTS	RTS A(-)	RTS (-)	TxD(-)
37	1/14	2		CTS A(-)	CTS A(-)	RxD Return

**Table 9:** DFlex-8 DB-78 pinouts

Pin No.	SLIM/Pin No.	Port No.	RS-232 Signal	RS-485 Signal	RS-423 Signal	Current Loop Signal
1	3-2	5	RTS	RTS A(-)	RTS (-)	TxD(-)
2	3-4	5	CTS	RTS B(+)	RTS Ref	RxD(+)
3	3-6	5	Reserved	CTS A(-)	CTS A(-)	RxD Return
4	3-8	5	Reserved	CTS B(+)	CTS B(+)	RxD Source
5		5	SG	SR	SR	SG
6	3-10	6	RTS	RTS A(-)	RTS (-)	TxD(-)
7	3-12	6	CTS	RTS B(+)	RTS Ref	RxD(+)
8	3-14	6	Reserved	CTS A(-)	CTS A(-)	RxD Return
9	3-16	6		CTS B(+)	CTS B(+)	RxD Source
10	4-2	7	RTS	RTS A(-)	RTS (-)	TxD(-)
11	4-4	7	CTS	RTS B(+)	RTS Ref	RxD(+)
12	4-6	7	Reserved	CTS A(-)	CTS A(-)	RxD Return
13	4-8	7	Reserved	CTS B(+)	CTS B(+)	RxD Source
14		7	SG	SR	SR	SG
15	4-10	8	RTS	RTS A(-)	RTS (-)	TxD(-)
16	4-12	8	CTS	RTS B(+)	RTS Ref	RxD(+)
17	4-14	8	Reserved	CTS A(-)	CTS A(-)	RxD Return
18	4-16	8		CTS B(+)	CTS B(+)	RxD Source
19	NC					
20	NC					
21	3-3	5	TxD	TxD A(-)	TxD (-)	TxD Source
22	3-5	5	RxD	TxD B(+)	TxD Ref	TxD(+)
23	3-7	5	DTR	RxD A(-)	RxD A(-)	TxD Return
24	3-9	5	DCD	RxD B(+)	RxD B(+)	RxD(-)
25		6	SG	SR	SR	SG
26	3-11	6	TxD	TxD A(-)	TxD (-)	TxD Source
27	3-13	6	RxD	TxD B(+)	TxD Ref	TxD(+)
28	3-15	6	DTR	RxD A(-)	RxD A(-)	TxD Return
29	3-17	6	DCD	RxD B(+)	RxD B(+)	RxD(-)
30	4-3	7	TxD	TxD A(-)	TxD (-)	TxD Source
31	4-5	7	RxD	TxD B(+)	TxD Ref	TxD(+)
32	4-7	7	DTR	RxD A(-)	RxD A(-)	TxD Return
33	4-9	7	DCD	RxD B(+)	RxD B(+)	RxD(-)
34	NC					
35	4-11	8	TxD	TxD A(-)	TxD (-)	TxD Source
36	4-13	8	RxD	TxD B(+)	TxD Ref	TxD(+)
37	4-15	8	DTR	RxD A(-)	RxD A(-)	TxD Return
38	4-17	8	DCD	RxD B(+)	RxD B(+)	RxD(-)
39		8	SG	SR	SR	SG

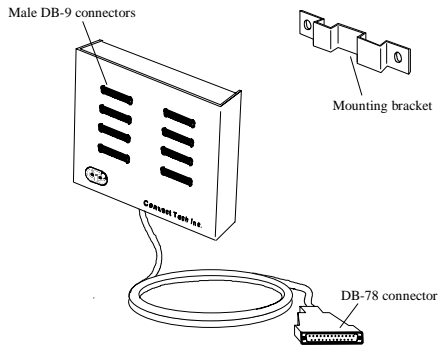
**Table 9(continued): DFlex-8 DB-78 pinouts**

Pin No.	SLIM/Pin No.	Port No.	RS-232 Signal	RS-485 Signal	RS-423 Signal	Current Loop Signal
40	1-2	1	RTS	RTS A(-)	RTS (-)	TxD(-)
41	1-4	1	CTS	RTS B(+)	RTS Ref	RxD(+)
42	1-6	1	Reserved	CTS A(-)	CTS A(-)	RxD Return
43	1-8	1	Reserved	CTS B(+)	CTS B(+)	RxD Source
44		1	SG	SR	SR	SG
45	1-10	2	RTS	RTS A(-)	RTS (-)	TxD(-)
46	1-12	2	CTS	RTS B(+)	RTS Ref	RxD(+)
47	1-14	2	Reserved	CTS A(-)	CTS A(-)	RxD Return
48	1-16	2		CTS B(+)	CTS B(+)	RxD Source
49	2-2	3	RTS	RTS A(-)	RTS (-)	TxD(-)
50	2-4	3	CTS	RTS B(+)	RTS Ref	RxD(+)
51	2-6	3	Reserved	CTS A(-)	CTS A(-)	RxD Return
52	2-8	3	Reserved	CTS B(+)	CTS B(+)	RxD Source
53		3	SG	SR	SR	SG
54	2-10	4	RTS	RTS A(-)	RTS (-)	TxD(-)
55	2-12	4	CTS	RTS B(+)	RTS Ref	RxD(+)
56	2-14	4	Reserved	CTS A(-)	CTS A(-)	RxD Return
57	2-16	4		CTS B(+)	CTS B(+)	RxD Source
58	NC					
59	NC					
60	1-3	1	TxD	TxD A(-)	TxD (-)	TxD Source
61	1-5	1	RxD	TxD B(+)	TxD Ref	TxD(+)
62	1-7	1	DTR	RxD A(-)	RxD A(-)	TxD Return
63	1-9	1	DCD	RxD B(+)	RxD B(+)	RxD(-)
64		2	SG	SR	SR	SG
65	1-11	2	TxD	TxD A(-)	TxD (-)	TxD Source
66	1-13	2	RxD	TxD B(+)	TxD Ref	TxD(+)
67	1-15	2	DTR	RxD A(-)	RxD A(-)	TxD Return
68	1-17	2	DCD	RxD B(+)	RxD B(+)	RxD(-)
69	2-3	3	TxD	TxD A(-)	TxD (-)	TxD Source
70	2-5	3	RxD	TxD B(+)	TxD Ref	TxD(+)
71	2-7	3	DTR	RxD A(-)	RxD A(-)	TxD Return
72	2-9	3	DCD	RxD B(+)	RxD B(+)	RxD(-)
73		4	SG	SR	SR	SG
74	2-11	4	TxD	TxD A(-)	TxD (-)	TxD Source
75	2-13	4	RxD	TxD B(+)	TxD Ref	TxD(+)
76	2-15	4	DTR	RxD A(-)	RxD A(-)	TxD Return
77	2-17	4	DCD	RxD B(+)	RxD B(+)	RxD(-)
78	NC					

### Connector Box /Pinouts

You may order the DFlex-8 with an external I/O Box option. The I/O Box option comes with a metal bracket that can be mounted on a wall or other surface. When you receive the I/O Box, this bracket is clipped on to the back of the connector box. If you wish to attach the I/O Box to a wall or other surface, just remove the bracket, fasten it in place, and then re-attach the connector box. If you wish to set the I/O Box on its rubber feet only, just remove the bracket from the back. See **Figure 27** for the orientation of the I/O Box and **Table 10** for the DB9 pinouts on the connector box.

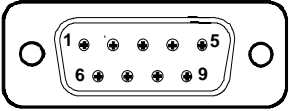
**Figure 27:** DFlex I/O Box



**Table 10: DB-9 pinouts - DFlex I/O Box**

Pin No.	RS-232 Signal	RS-485 Signal	RS-423 Signal	Current Loop Signal
1	DCD	RxD B(+)	RxD(+)	RxD(-)
2	RxD	TxD B(+)	TxD Ref	TxD(+)
3	TxD	TxD A(-)	TxD(-)	TxD Source
4	DTR	RxD A(-)	RxD(-)	TxD Return
5	SG	SR	SR	SG
6	Reserved	CTS A(-)	CTS(-)	RxD Return
7	RTS	RTS A(-)	RTS(-)	TxD(-)
8	CTS	RTS B(+)	RTS Ref	RxD(+)
9	Reserved	CTS B(+)	CTS(+)	RxD Source

Male DB-9 Connector



**Technical Tip:**

*Please ensure that you terminate the DCD or CTS signals if your application does not use them. The common way to do this is to connect DCD to DTR and/or to connect CTS to RTS. Failure to do so may result in a loss of a performance on your DFlex adapter.*

**SLIM Pinouts**

**Table 11** shows the pinouts for the Connect Tech Serial Line Interfaces Modules.

**Table 11:** *SLIM pinouts*

SLIM Pin No.	TTL Signal	RS-232 Signal	RS-485 Signal	RS-423 Signal	Current Loop Signal
1	Reserved				
2		RTS 1	RTS A(-) 1	RTS (-) 1	TxD(-) 1
3		TxD 1	TxD A(-) 1	TxD (-) 1	TxD Source 1
4		CTS 1	RTS B(+) 1	RTS Ref 1	RxD(+) 1
5		RxD 1	TxD B(+) 1	TxD Ref 1	TxD(+) 1
6		Reserved	CTS A(-) 1	CTS A(-) 1	RxD Return 1
7		DTR 1	RxD A(-) 1	RxD A(-) 1	TxD Return 1
8		Reserved	CTS B(+) 1	CTS B(+) 1	RxD Source 1
9		DCD 1	RxD B(+) 1	RxD B(+) 1	RxD(-) 1
10		RTS 2	RTS A(-) 2	RTS (-) 2	TxD(-) 2
11		TxD 2	TxD A(-) 2	TxD (-) 2	TxD Source 2
12		CTS 2	RTS B(+) 2	RTS Ref 2	RxD(+ 2
13		RxD 2	TxD B(+) 2	TxD Ref 2	TxD(+ 2
14		Reserved	CTS A(-) 2	CTS A(-) 2	RxD Return 2
15		DTR 2	RxD A(-) 2	RxD A(-) 2	TxD Return 2
16		NC	CTS B(+) 2	CTS B(+) 2	RxD Source 2
17		DCD 2	RxD B(+) 2	RxD B(+) 2	RxD(-) 2
18	Ground				
19	+12 V				
20	-12 V				
21	+5 V				
22	DCD 2		Tied high	Tied high	Tied high
23	CTS 2				Tied high
24	RTS 2				
25	DTR 2				
26	TxD 2				
27	RxD 2				
28	RxD 1				
29	TxD 1				
30	DTR 1				
31	RTS 1				
32	CTS 1				Tied high
33	DCD 1		Tied high	Tied high	Tied high
34	TC				
35	RC				

**Note:** earlier versions of the current loop SLIM have pins 22, 23, 32, and 33 tied low.



## Appendix C: Factory Settings

Appendix C summarizes the factory settings for the following DFflex hardware components:

- DFflex-2; DFflex-2/Fast
- DFflex-4; DFflex-4/Fast
- DFflex-8

### DFflex-2; DFflex-2/Fast

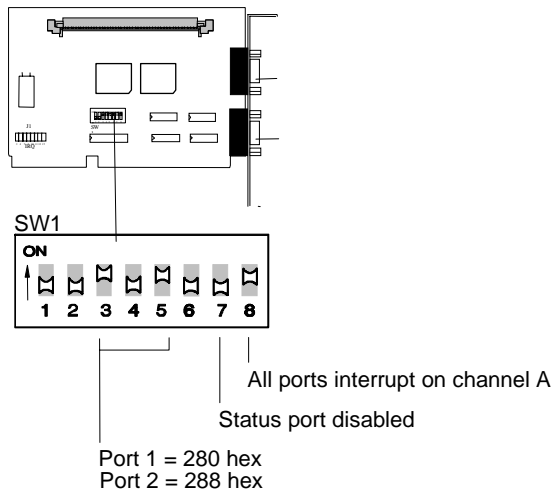
The DFflex-2 and DFflex-2/Fast ship with factory settings for the following:

- I/O port address
- IRQ (Interrupt Request line)

### I/O Port Address Setting

The DIP switches on switch block SW1 sets the I/O port addresses for the DFflex-2 and DFflex-2/Fast adapters. Connect Tech ships these adapters with SW1 set for: I/O port addresses 280, 288 hex; status port disabled; and all ports interrupting on channel A. **Figure 28** shows the location and factory setting of SW1.

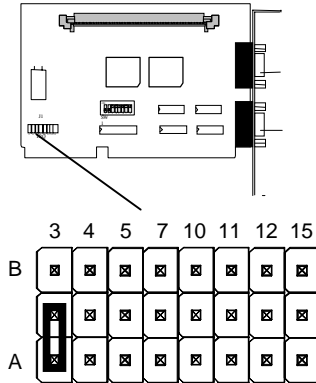
**Figure 28:** DFflex-2/-2/Fast: SW1 factory settings



**IRQ Setting**

Jumper block J1 sets the IRQ line for the DFlex-2 and DFlex-2/Fast adapters. Connect Tech ships these adapters with J1 set for IRQ 3, interrupting on channel A. **Figure 29** shows the location and factory setting of J1.

**Figure 29:** DFlex-2/-2/Fast: J1 factory setting



*Note: all ports use IRQ 3 on channel A*

**DFlex-4; DFlex-4/Fast**

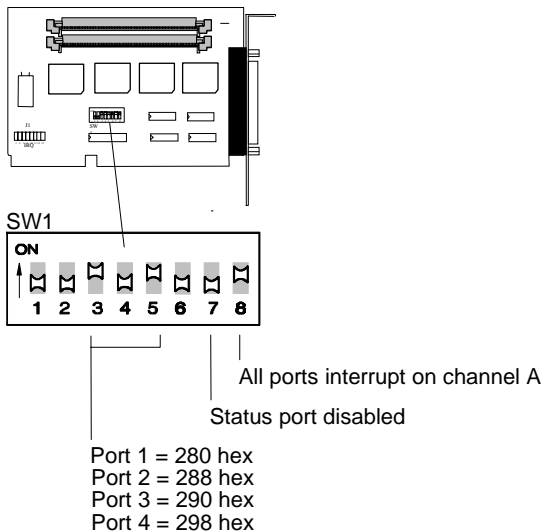
The DFlex-4 and DFlex-4/Fast ships with factory settings for the following:

- I/O port address
- IRQ (Interrupt Request line)

**I/O Port Address Setting**

The DIP switches on switch block SW1 sets the I/O port addresses for the DFlex-4 and DFlex-4/Fast adapter. Connect Tech ships these adapters with SW1 set for I/O port addresses 280, 288, 290, 298 hex; status port disabled; and all ports interrupting on channel A. **Figure 30** shows the location and factory setting of SW1.

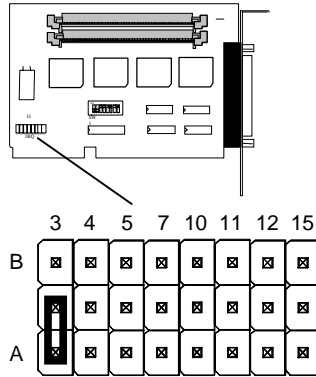
**Figure 30:** *DFlex-4/-4/Fast: SW1 factory settings*



**IRQ Setting**

Jumper blocks J1 sets the IRQ line for the DFlex-4 and DFlex-4/Fast adapter. Connect Tech ships these adapters with J1 set for IRQ 3, interrupting on channel A. **Figure 31** shows the location and factory setting of J1.

**Figure 31:** DFlex-4; DFlex-4/Fast: J1 factory setting



**Note:** all ports use IRQ 3 on channel A

## DFlex-8

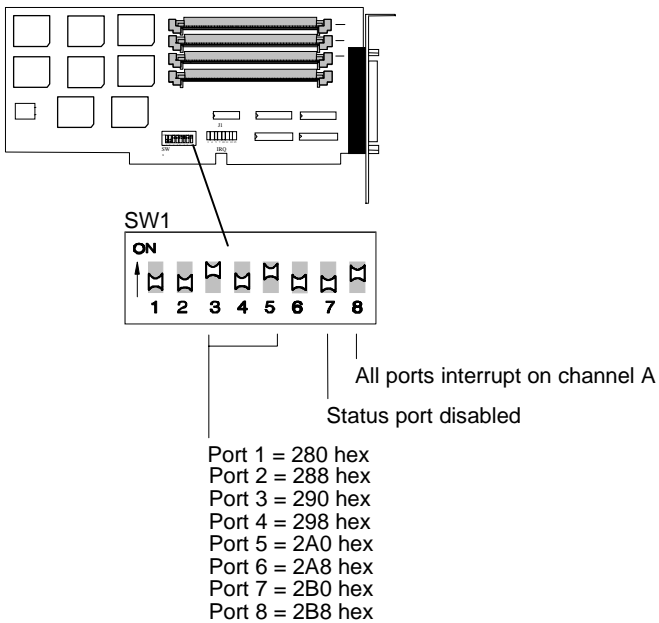
The DFlex-8 ships with factory settings for the following:

- I/O port address
- IRQ (Interrupt Request line)

### I/O Port Address Setting

The DIP switches on switch block SW1 sets the I/O port addresses for the DFlex-8 adapter. Connect Tech ships the DFlex-8 adapter with SW1 set for: I/O port addresses 280, 288, 290, 298, 2A0, 2A8, 2B0, 2B8 hex; status port disabled; and all ports interrupting on channel A. **Figure 32** shows the location and factory setting of SW1.

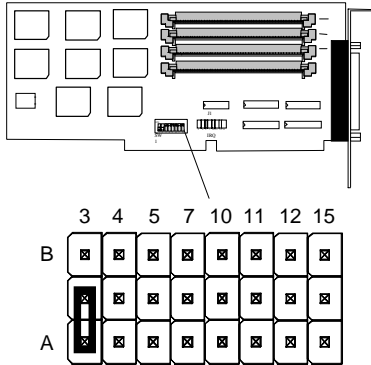
**Figure 32:** DFlex-8: SW1 factory settings



**IRQ Setting**

Jumper block J1 sets the IRQ line for the DFlex-8 adapter. Connect Tech ships the DFlex-8 with J1 set for IRQ 3, interrupting on channel A. **Figure 33** shows the location and factory setting of J1.

**Figure 33:** DFlex-8 J1 factory setting



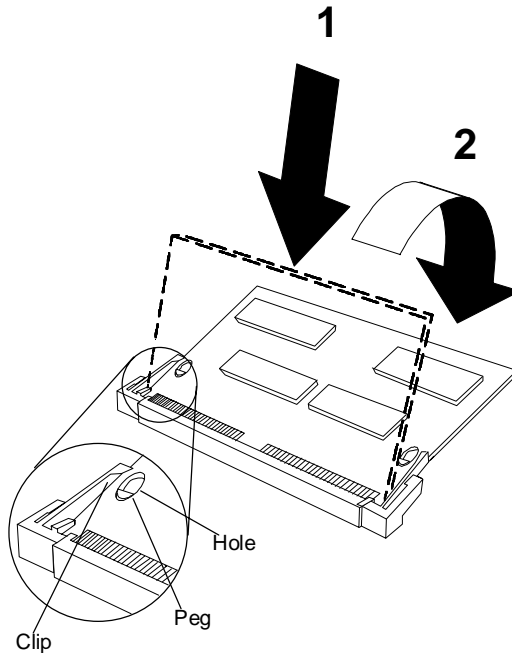
*Note: all ports use IRQ 3 on channel A*

## Appendix D: SLIM Insertion/Removal

### SLIM insertion

**Figure 34** outlines the correct procedure for inserting RS-232, RS-485/422, RS-423, and 20mA current loop Serial Line Interface Module (SLIM).

**Figure 34:** *SLIM insertion*

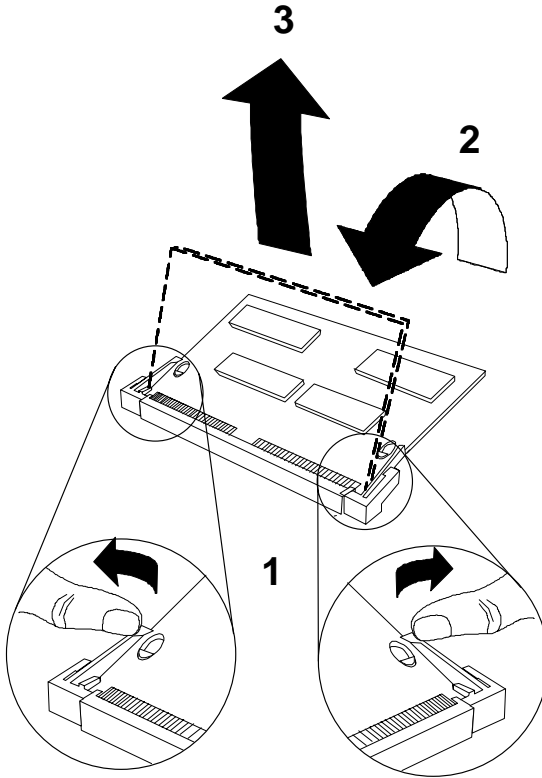


1. Place the SLIM into the socket almost vertically (about 75-degree angle), making sure that it is properly oriented and fully inserted into the socket.
2. Press downward and sideways on the SLIM until it latches into the socket. **Do NOT force the SLIM**, the installation process requires a small force and should be very smooth and easy. If you encounter resistance then re-check the orientation and insertion depth.

**SLIM removal**

**Figure 35** outlines the correct procedure for removing a RS-232, RS-423, RS-485/422, and 20mA current loop Serial Line Interface Module (SLIM).

**Figure 35:** *SLIM removal*



1. Using both hands, place your thumbs on the clips that hold the SLIM into the socket, and place your index fingers on the edge of the SLIM.
2. Push outwards (with your thumbs) on the clips until the SLIM is released from the clips. Your index fingers can then raise the SLIM past the clips. The SLIM is then free to be removed from the DFlex board. The force required to open the clips is small and the SLIM naturally springs upwards as soon as the clips are open wide enough. If removal is difficult, then you are probably trying to raise the SLIM before the clips are open.

---

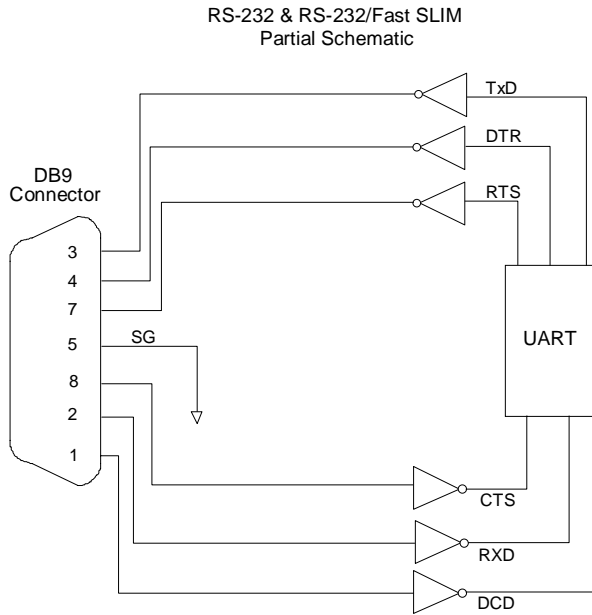
## **Appendix E: RS-232 Option**

You may order various models of DFlex adapters with RS-232 and RS-232/Fast Serial Line Interface Modules. The RS-232 and RS-232/Fast SLIMs offer the following features:

- The RS-232 electrical interface, an industry standard that offers connection to a wide range of peripheral devices.
- Each SLIM controls two ports.
- SLIMs are field upgradeable, providing you with more flexibility for your application.

Please refer to **Figure 36** for a partial schematic of the RS-232 or RS-232/Fast SLIM

**Figure 36:** RS-232; RS-232/Fast SLIM: partial schematic



**Note:** The RS-232 and RS-232/Fast Serial Line Interface Module controls two ports, and therefore the schematic shows only a portion of the circuit.

### RS-232/Fast SLIM

The standard RS-232 SLIM is not functional with the DFlex/Fast adapters due to the faster baud rates. Only the RS-232/Fast Serial Line Interface Modules (SLIM) is compatible with the DFlex-2/Fast and DFlex-4/Fast adapters.

### Installation

The DFlex adapter has one, two or four SLIM sockets which accept Serial Line Interface Modules. SLIM 1 socket (S1) interfaces ports 1 and 2. SLIM 2 socket (S2) interfaces ports 3 and 4. SLIM 3 socket (S3) interfaces ports 5 and 6. SLIM 4 socket (S4) interfaces ports 7 and 8. Please refer to **Chapter 2: Hardware Installation** for the location of the SLIM sockets and to **Appendix D: SLIM Insertion/Removal** for the proper procedures to installing and removing SLIMs.



*Your DFlex adapter and Serial Line Interface Module (SLIM) are very sensitive to static electricity. Make sure that before you remove them from the anti-static shipping bag, you wear an anti-static wrist-band. When you remove them from the anti-static bag, handle them only by the edges and place them on the anti-static bag or an anti-static mat.*

Please refer to **Table 12** for the pinouts for the SLIM sockets found on the DFlex adapter.

**Table 12:** *SLIM socket pinouts*

SLIM Pin No.	TTL Signal	RS-232 Signal	RS-485 Signal	RS-423 Signal	Current Loop Signal
1	Reserved				
2		RTS 1	RTS A(-) 1	RTS (-) 1	TxD(-) 1
3		TxD 1	TxD A(-) 1	TxD (-) 1	TxD Source 1
4		CTS 1	RTS B(+) 1	RTS Ref 1	RxD(+) 1
5		RxD 1	TxD B(+) 1	TxD Ref 1	TxD(+ ) 1
6		Reserved	CTS A(-) 1	CTS A(-) 1	RxD Return 1
7		DTR 1	RxD A(-) 1	RxD A(-) 1	TxD Return 1
8		Reserved	CTS B(+) 1	CTS B(+) 1	RxD Source 1
9		DCD 1	RxD B(+) 1	RxD B(+) 1	RxD(-) 1
10		RTS 2	RTS A(-) 2	RTS (-) 2	TxD(-) 2
11		TxD 2	TxD A(-) 2	TxD (-) 2	TxD Source 2
12		CTS 2	RTS B(+) 2	RTS Ref 2	RxD(+ ) 2
13		RxD 2	TxD B(+) 2	TxD Ref 2	TxD(+ ) 2
14		Reserved	CTS A(-) 2	CTS A(-) 2	RxD Return 2
15		DTR 2	RxD A(-) 2	RxD A(-) 2	TxD Return 2
16		NC	CTS B(+) 2	CTS B(+) 2	RxD Source 2
17		DCD 2	RxD B(+) 2	RxD B(+) 2	RxD(-) 2
18	Ground				
19	+12 V				
20	-12 V				
21	+5 V				
22	DCD 2		Tied high	Tied high	Tied high
23	CTS 2				Tied high
24	RTS 2				
25	DTR 2				
26	TxD 2				
27	RxD 2				
28	RxD 1				
29	TxD 1				
30	DTR 1				
31	RTS 1				
32	CTS 1				Tied high
33	DCD 1		Tied high	Tied high	Tied high
34	TC				
35	RC				

**Note:** *earlier versions of the current loop SLIM have pins 22, 23, 32, and 33 tied low.*

## Appendix F: RS-485/422 Option

You may order various models of DFlex adapters with RS-485/422 Serial Line Interface Modules. The RS-485/422 electrical interface is a reliable high speed serial link that offers superior noise immunity and multi-drop network connectivity. The RS-485/422 electrical interface is also a superset of the RS-422 electrical interface. The DFlex adapters that offer a RS-485/422 interface option are:

- DFlex-2; DFlex-2/Fast
- DFlex-4; DFlex-4/Fast
- DFlex-8

### WARNING

*You must insert Serial Line Interface Modules into all of the SLIM sockets before operating your DFlex adapter. Failure to observe this precaution will result in damage to the DFlex adapter.*

**RS-485/422 SLIM**

The RS-485/422 SLIM can be used in 2 wire and multi-drop configurations where the drivers will have to be disabled to allow other devices access to the line.

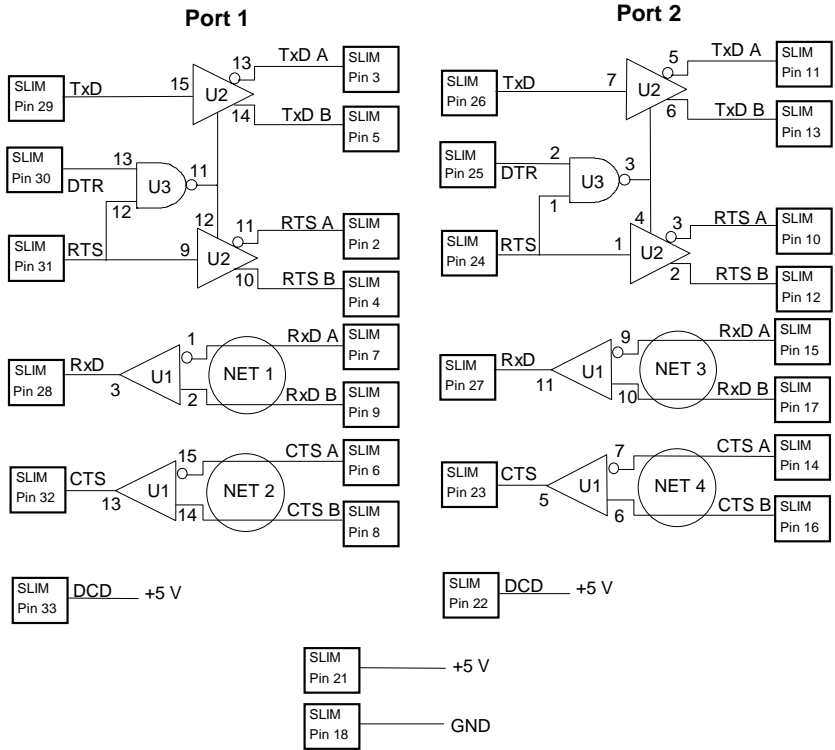
Your DFlex adapter does not provide DIP switches to control the driver enables for the RS485 SLIM. Instead, the DTR signal is used to gate the control. If DTR is asserted, the drivers are always enabled. If DTR is not asserted, then the driver will be enabled only when RTS is asserted.

Also, the RS485 SLIM does not provide locations for biasing resistors. Each receiver is biased high through fixed resistors. Please refer to **Figure 37** for a partial schematic of the RS-485/422 SLIM circuit, while **Table 13** shows the pinouts for the SLIM sockets found on the DFlex adapters.

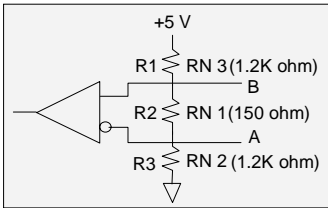


*Your DFlex adapter is very sensitive to static electricity. Make sure that before you remove the card from the anti-static shipping bag, you wear an anti-static wrist-band. When you remove the board from the anti-static bag, handle it only by the edges and place it on the anti-static bag or an anti-static mat.*

**Figure 37: RS-485/422 SLIM partial schematic**



Network detail



	RN 1 (150 ohm)	RN 2, RN 3 (1.2k ohm)
Net #	Pin #	Pin #
Net 1	7, 8	5
Net 2	5, 6	4
Net 3	3, 4	3
Net 4	1, 2	2

**Note:** As a RS-485/422 Serial Line Interface Module controls two ports, the schematic shows the circuit for two ports.

## Installation

The DFlex adapter has one, two or four SLIM sockets which accept Serial Line Interface Modules. SLIM 1 socket (S1) interfaces ports 1 and 2. SLIM 2 socket (S2) interfaces ports 3 and 4. SLIM 3 socket (S3) interfaces ports 5 and 6. SLIM 4 socket (S4) interfaces ports 7 and 8. Please refer to **Chapter 2: Hardware Installation** for the location of the SLIM sockets and to **Appendix D: SLIM Insertion/Removal** for the proper procedures to installing and removing SLIMs.



*Your DFlex adapter and Serial Line Interface Module (SLIM) are very sensitive to static electricity. Make sure that before you remove them from the anti-static shipping bag, you wear an anti-static wrist-band. When you remove them from the anti-static bag, handle them only by the edges and place them on the anti-static bag or an anti-static mat.*

Please refer to **Table 13** for the pinouts for the SLIM sockets found on the DFlex adapter.

**Table 13:** *SLIM socket pinouts*

SLIM Pin No.	TTL Signal	RS-232 Signal	RS-485 Signal	RS-423 Signal	Current Loop Signal
1	Reserved				
2		RTS 1	RTS A(-) 1	RTS (-) 1	TxD(-) 1
3		TxD 1	TxD A(-) 1	TxD (-) 1	TxD Source 1
4		CTS 1	RTS B(+) 1	RTS Ref 1	RxD(+) 1
5		RxD 1	TxD B(+) 1	TxD Ref 1	TxD(+) 1
6		Reserved	CTS A(-) 1	CTS A(-) 1	RxD Return 1
7		DTR 1	RxD A(-) 1	RxD A(-) 1	TxD Return 1
8		Reserved	CTS B(+) 1	CTS B(+) 1	RxD Source 1
9		DCD 1	RxD B(+) 1	RxD B(+) 1	RxD(-) 1
10		RTS 2	RTS A(-) 2	RTS (-) 2	TxD(-) 2
11		TxD 2	TxD A(-) 2	TxD (-) 2	TxD Source 2
12		CTS 2	RTS B(+) 2	RTS Ref 2	RxD(+) 2
13		RxD 2	TxD B(+) 2	TxD Ref 2	TxD(+) 2
14		Reserved	CTS A(-) 2	CTS A(-) 2	RxD Return 2
15		DTR 2	RxD A(-) 2	RxD A(-) 2	TxD Return 2
16		NC	CTS B(+) 2	CTS B(+) 2	RxD Source 2
17		DCD 2	RxD B(+) 2	RxD B(+) 2	RxD(-) 2
18	Ground				
19	+12 V				
20	-12 V				
21	+5 V				
22	DCD 2		Tied high	Tied high	Tied high
23	CTS 2				Tied high
24	RTS 2				
25	DTR 2				
26	TxD 2				
27	RxD 2				
28	RxD 1				
29	TxD 1				
30	DTR 1				
31	RTS 1				
32	CTS 1				Tied high
33	DCD 1		Tied high	Tied high	Tied high
34	TC				
35	RC				

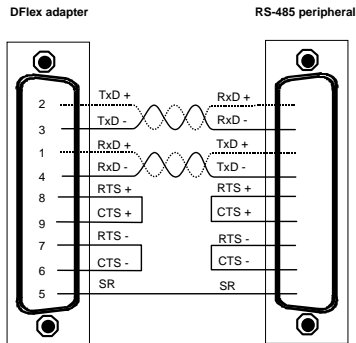
**Note:** *earlier versions of the current loop SLIM have pins 22, 23, 32, and 33 tied low.*

### RS-485/422 Cable Wiring

You can wire DFlex adapters with the RS-485/422 option in various ways to communicate with RS-485/422 peripherals. This section will describe a few examples of RS-485/422 cabling schemes.

**Figure 38** describes a 4 wire cabling scheme between a port on the DFlex adapter to a port on the RS-485/422 peripheral.

**Figure 38:** RS-485/422 wiring diagram (4 wire)

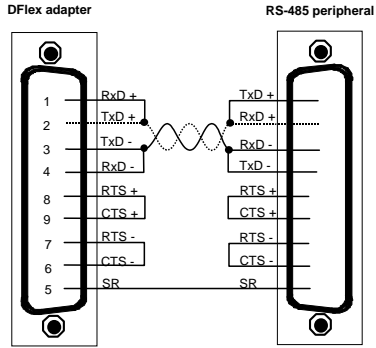


#### **Technical Tip**

*The RS-485/422 electrical interface consists of a differential signaling scheme. You should always connect the signals with twisted pairs.*

**Figure 39** describes a 2 wire cabling scheme between a port on the DFlex adapter to a port on the RS-485/422 peripheral.

**Figure 39:** RS-485/422 wiring diagram (2 wire)



**Technical Tip**

The RS-485/422 electrical interface consists of a differential signaling scheme. **You should always connect the signals with twisted pairs.**



---

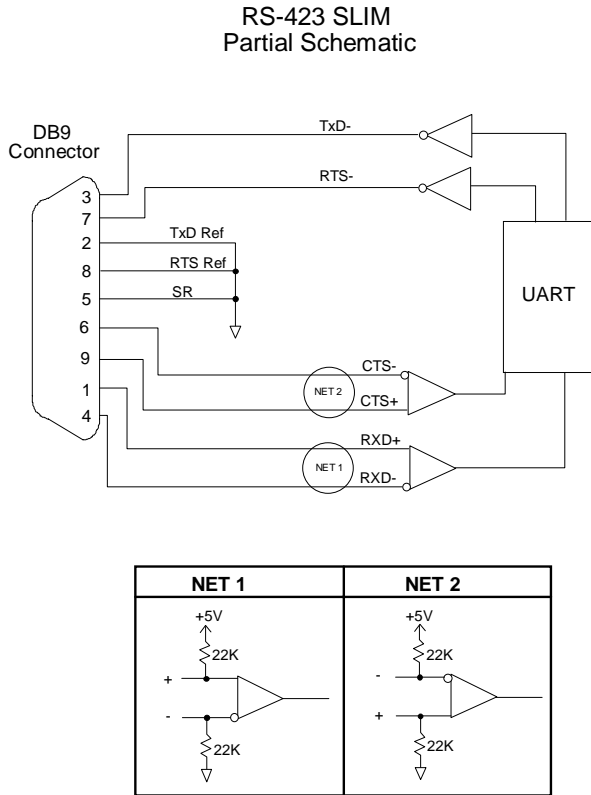
## Appendix G: RS-423 Option

You may order various models of DFlex adapters with RS-423 Serial Line Interfaces Module. The RS-423 electrical interface is a reliable high speed serial link that offers superior noise immunity. The DFlex adapters that offer a RS-423 interface option are:

- DFlex-2; DFlex-2/Fast
- DFlex-4; DFlex-4/Fast
- DFlex-8

Please refer to **Figure 40** for a partial schematic of the RS-423 SLIM circuit

**Figure 40:** RS-423 SLIM partial schematic



**Note:** The RS-423 Serial Line Interface Module controls two ports, and therefore the schematic shows only a portion of the circuit.

### Installation

The DFlex adapter has one, two or four SLIM sockets which accept Serial Line Interface Modules. SLIM 1 socket (S1) interfaces ports 1 and 2. SLIM 2 socket (S2) interfaces ports 3 and 4. SLIM 3 socket (S3) interfaces ports 5 and 6. SLIM 4 socket (S4) interfaces ports 7 and 8. Please refer to **Chapter 2: Hardware Installation** for the location of the SLIM sockets and to **Appendix D: SLIM Insertion/Removal** for the proper procedures to installing and removing SLIMs.



*Your DFlex adapter and Serial Line Interface Module (SLIM) are very sensitive to static electricity. Make sure that before you remove them from the anti-static shipping bag, you wear an anti-static wrist-band. When you remove them from the anti-static bag, handle them only by the edges and place them on the anti-static bag or an anti-static mat.*

Please refer to **Table 14** for the pinouts for the SLIM sockets found on the DFlex adapter.

**Table 14:** *SLIM socket pinouts*

SLIM Pin No.	TTL Signal	RS-232 Signal	RS-485 Signal	RS-423 Signal	Current Loop Signal
1	Reserved				
2		RTS 1	RTS A(-) 1	RTS (-) 1	TxD(-) 1
3		TxD 1	TxD A(-) 1	TxD (-) 1	TxD Source 1
4		CTS 1	RTS B(+) 1	RTS Ref 1	RxD(+) 1
5		RxD 1	TxD B(+) 1	TxD Ref 1	TxD(+) 1
6		Reserved	CTS A(-) 1	CTS A(-) 1	RxD Return 1
7		DTR 1	RxD A(-) 1	RxD A(-) 1	TxD Return 1
8		Reserved	CTS B(+) 1	CTS B(+) 1	RxD Source 1
9		DCD 1	RxD B(+) 1	RxD B(+) 1	RxD(-) 1
10		RTS 2	RTS A(-) 2	RTS (-) 2	TxD(-) 2
11		TxD 2	TxD A(-) 2	TxD (-) 2	TxD Source 2
12		CTS 2	RTS B(+) 2	RTS Ref 2	RxD(+) 2
13		RxD 2	TxD B(+) 2	TxD Ref 2	TxD(+) 2
14		Reserved	CTS A(-) 2	CTS A(-) 2	RxD Return 2
15		DTR 2	RxD A(-) 2	RxD A(-) 2	TxD Return 2
16		NC	CTS B(+) 2	CTS B(+) 2	RxD Source 2
17		DCD 2	RxD B(+) 2	RxD B(+) 2	RxD(-) 2
18	Ground				
19	+12 V				
20	-12 V				
21	+5 V				
22	DCD 2		Tied high	Tied high	Tied high
23	CTS 2				Tied high
24	RTS 2				
25	DTR 2				
26	TxD 2				
27	RxD 2				
28	RxD 1				
29	TxD 1				
30	DTR 1				
31	RTS 1				
32	CTS 1				Tied high
33	DCD 1		Tied high	Tied high	Tied high
34	TC				
35	RC				

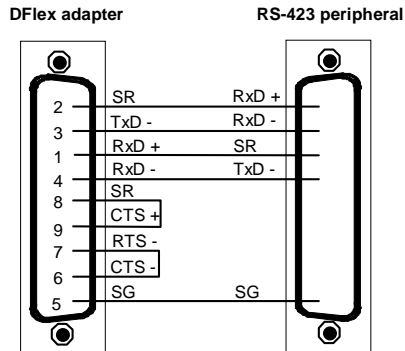
**Note:** *earlier versions of the current loop SLIM have pins 22, 23, 32, and 33 tied low.*

## RS-423 Cable Wiring

You can wire DFlex adapters with the RS-423 option in various ways to communicate with RS-423 peripherals. This section will describe a few examples of RS-423 cabling schemes.

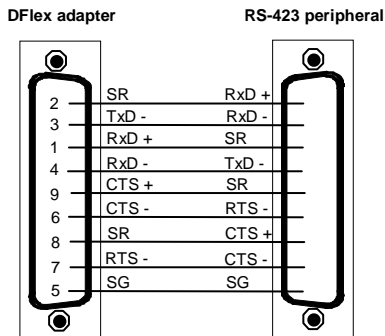
**Figure 41** describes a 4 wire cabling scheme between a port on the DFlex adapter to a port on the RS-423 peripheral.

**Figure 41:** RS-423 wiring diagram (4 wire)



**Figure 42** describes an all wire cabling scheme between a port on the DFlex adapter to a port on the RS-423 peripheral.

**Figure 42:** RS-423 wiring diagram (all wire)





## Appendix H: 20mA Current Loop Option

You may order DFlex adapters with 20mA current loop Serial Line Interface Modules. The 20mA current loop electrical interface provides a reliable high speed serial link over long distances that offers superior noise immunity and multi-drop network connectivity. The DFlex adapters that offer a 20mA current loop interface option are:

- DFlex-2
- DFlex-4
- DFlex-8

### WARNING

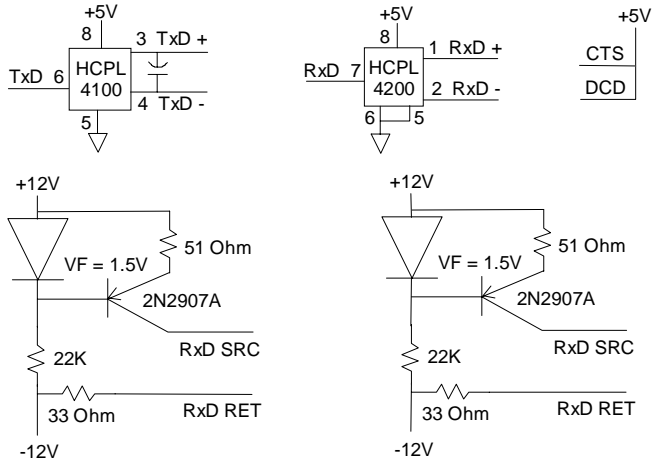
*You must insert Serial Line Interface Modules into all of the SLIM sockets before operating your DFlex adapter. Failure to observe this precaution will result in damage to the DFlex adapter.*

### 20mA Current Loop SLIM

The 20mA current loop module provides optically isolated 20mA active or passive current loop interfaces for two ports. For each port there is an isolated receiver, an optically isolated transmitter and two 20mA current sources. See **Figure 43** for the schematic of the 20mA current loop module.

***Note:** The current source uses a compliance voltage of 24 volts, and the transmitter will withstand a 27 volt drop. Please refer to the Hewlett Packard Optoelectronics Manual/Catalogue for a complete description of HPCL 4100 and HPCL 4200 specifications.*

**Figure 43:** 20mA Current Loop schematic



Where:

SLIM Pin No.	Current Loop Signal	SLIM Pin No.	Current Loop Signal
2	TxD(-) 1	14	RxD Return 2
3	TxD Source 1	15	TxD Return 2
4	RxD(+) 1	16	RxD Source 2
5	TxD(+) 1	17	RxD(-) 2
6	RxD Return 1	18	Gnd
7	TxD Return 1	19	+12 V
8	RxD Source 1	20	-12 V
9	RxD(-) 1	21	+5 V
10	TxD(-) 2	22	DCD 2 (+5 V)
11	TxD Source 2	23	CTS 2 (+5 V)
12	RxD(+) 2	32	CTS 1 (+5 V)
13	TxD(+) 2	33	DCD 1 (+5 V)

To implement a passive interface, wire the transmitter and the receiver, while leaving the current sources unconnected. An external current source is required to implement a passive interface.

To implement an active interface, connect a 20mA current source in series with the transmitter and another 20mA current source in series with the receiver. Please refer to **Figure 44** for a 20mA current loop cable wiring configuration between one port of a DFlex adapter and another port of a DFlex adapter. This example shows wiring for both active and passive modes.

When you use a current loop SLIM as a current source in the loop and the 20mA is flowing, the corresponding LED on the Serial Line Interface Module will light. If the loop is open or the current loop SLIM is not used as a current source the LED will be off.

## WARNING

*When using the current source in a loop with low resistance, the transistor will run hot. This can be avoided by increasing the loop resistance. The calculation for Maximum Loop Resistance ( $R_L$ ) is:*

$$\text{MAX } R_L = \frac{22 - (S \times V_D)}{0.020}$$

**Note:**

1.  $S$  = the number of stations in the loop (TX's and RX's)
2.  $V_D$  = the voltage drop for the HP opto couplers on the SLIM.  $V_D = 2.3$  V for the HPCL 4100 and HPCL 4200. When you use other manufacturers' equipment in the loop the value of  $V_D$  may differ.

## Installation

The DFflex adapter has one, two or four SLIM sockets which accept Serial Line Interface Modules. SLIM 1 socket (S1) interfaces ports 1 and 2. SLIM 2 socket (S2) interfaces ports 3 and 4. SLIM 3 socket (S3) interfaces ports 5 and 6. SLIM 4 socket (S4) interfaces ports 7 and 8. Please refer to **Chapter 2: Hardware Installation** for the location of the SLIM sockets and to **Appendix D: SLIM Insertion/Removal** for the proper procedures to installing and removing SLIMs.



*Your DFflex adapter and Serial Line Interface Module (SLIM) are very sensitive to static electricity. Make sure that before you remove them from the anti-static shipping bag, you wear an anti-static wrist-band. When you remove them from the anti-static bag, handle them only by the edges and place them on the anti-static bag or an anti-static mat.*

Please refer to **Table 15** for the pinouts for the SLIM sockets found on the DFflex adapter.

**Table 15:** *SLIM socket pinouts*

SLIM Pin No.	TTL Signal	RS-232 Signal	RS-485 Signal	RS-423 Signal	Current Loop Signal
1	Reserved				
2		RTS 1	RTS A(-) 1	RTS (-) 1	TxD(-) 1
3		TxD 1	TxD A(-) 1	TxD (-) 1	TxD Source 1
4		CTS 1	RTS B(+) 1	RTS Ref 1	RxD(+) 1
5		RxD 1	TxD B(+) 1	TxD Ref 1	TxD(+ ) 1
6		Reserved	CTS A(-) 1	CTS A(-) 1	RxD Return 1
7		DTR 1	RxD A(-) 1	RxD A(-) 1	TxD Return 1
8		Reserved	CTS B(+) 1	CTS B(+) 1	RxD Source 1
9		DCD 1	RxD B(+) 1	RxD B(+) 1	RxD(-) 1
10		RTS 2	RTS A(-) 2	RTS (-) 2	TxD(-) 2
11		TxD 2	TxD A(-) 2	TxD (-) 2	TxD Source 2
12		CTS 2	RTS B(+) 2	RTS Ref 2	RxD(+ ) 2
13		RxD 2	TxD B(+) 2	TxD Ref 2	TxD(+ ) 2
14		Reserved	CTS A(-) 2	CTS A(-) 2	RxD Return 2
15		DTR 2	RxD A(-) 2	RxD A(-) 2	TxD Return 2
16		NC	CTS B(+) 2	CTS B(+) 2	RxD Source 2
17		DCD 2	RxD B(+) 2	RxD B(+) 2	RxD(-) 2
18	Ground				
19	+12 V				
20	-12 V				
21	+5 V				
22	DCD 2		Tied high	Tied high	Tied high
23	CTS 2				Tied high
24	RTS 2				
25	DTR 2				
26	TxD 2				
27	RxD 2				
28	RxD 1				
29	TxD 1				
30	DTR 1				
31	RTS 1				
32	CTS 1				Tied high
33	DCD 1		Tied high	Tied high	Tied high
34	TC				
35	RC				

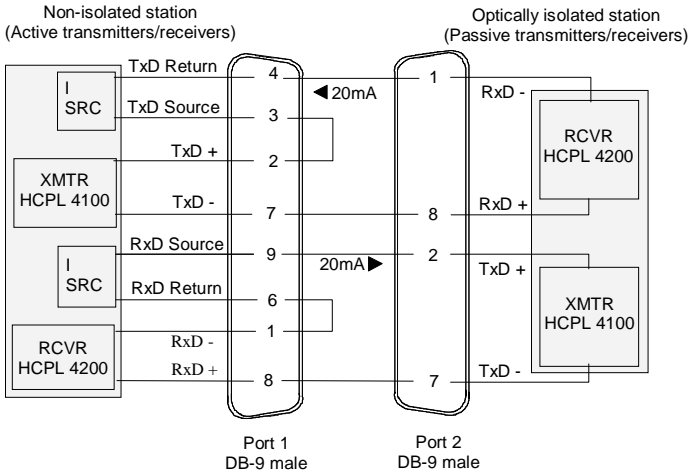
**Note:** *earlier versions of the current loop SLIM have pins 22, 23, 32, and 33 tied low.*

### Current Loop Cable Wiring

You can wire DFlex adapters with the 20mA Current Loop option in various ways to communicate with 20mA Current Loop peripherals. This section will describe a few examples of current loop cabling schemes.

**Figure 44** describes a 4 wire cabling scheme between a port on the DFlex adapter to another port on the DFlex adapter.

**Figure 44:** *Current Loop wiring diagram(4 wire)*



**Note:**

*The example above illustrates a 20mA current loop cable wiring configuration between one port of an DFlex adapter and another port of an DFlex adapter. This example shows wiring for both active and passive modes.*



