



Connect Tech Inc.

DFlex-4/104

Multi-port Serial Communications Adapter

User Manual

Connect Tech Inc
727 Speedvale Avenue West
Guelph, Ontario
N1K 1E6
Tel: (519) 836-1291
1-800-426-8979
Fax: (519) 836-4878
Email: sales@connecttech.com
FTP: [ftp.connecttech.com](ftp://ftp.connecttech.com)
URL: <http://www.connecttech.com>

CTI-0144, Revision 0.02 January 31 1999
Part Number: MAN045

LIMITED WARRANTY

Connect Tech Inc. warrants to the original purchaser of this Connect Tech hardware product that it is to be in good working order for a period of one year from the date of purchase from Connect Tech Inc. or an authorized Connect Tech dealer. Should this product, in Connect Tech Inc.'s opinion, fail to be in good working order during the warranty period, Connect Tech Inc. will, at its option, repair or replace this product at no charge, **provided that the product has not been subjected to abuse, misuse, accident, disaster or non Connect Tech Inc. authorized modification or repair.**

You may obtain Limited Warranty service by delivering this product to an authorized Connect Tech dealer or to Connect Tech Inc. along with proof of purchase. If this product is shipped, you agree to insure the product or assume risk of loss or damage in transit, and to prepay shipping charges to the warranty repair location.

The above warranty is the only warranty authorized by Connect Tech Inc. **UNDER NO CIRCUMSTANCES WILL CONNECT TECH INC. BE LIABLE IN ANY WAY FOR ANY DAMAGES, INCLUDING ANY LOST PROFITS, LOST SAVINGS OR OTHER INCIDENTAL OR CONSEQUENTIAL DAMAGES ARISING OUT OF THE USE OF, OR INABILITY TO USE, SUCH PRODUCT**

Copyright Notice

The information contained in this document is subject to change without notice. Connect Tech shall not be liable for errors contained herein or for incidental consequential damages in connection with the furnishing, performance, or use of this material. This document contains proprietary information that is protected by copyright. All rights are reserved. No part of this document may be photocopied, reproduced, or translated to another language without the prior written consent of Connect Tech, Inc.

Copyright © 1987, 1988, 1989, 1990, 1996, 1997, 1998 and 1999 by Connect Tech, Inc.

Trademark Acknowledgment

Connect Tech, Inc. acknowledges all trademarks, registered trademarks and/or copyrights referred to in this document as the property of their respective owners.

Not listing all possible trademarks or copyright acknowledgments does not constitute a lack of acknowledgment to the rightful owners of the trademarks and copyrights mentioned in this document.

Certification**DFlex-4/104**

The DFlex-4/104 is to be included into a device ultimately subject to FCC, DOC/IC, and CE certification. The customer is responsible for bringing the completed device into compliance prior to resale.

Table of Contents

Chapter 1: Introduction

Introduction.....	1-1
Manual Overview.....	1-1
Conventions & Symbols	1-2
Product Overview.....	1-3
DFlex-4/104 Adapter.....	1-3
DFlex-4/104 Software	1-6
Customer Service Overview.....	1-6
RMA Overview.....	1-9

Chapter 2: Hardware Installation

Introduction.....	2-1
Configuration	2-1
Port Addresses	2-2
Status Port Addresses	2-3
Custom Port Addresses.....	2-4
Interrupt Selection.....	2-6
Mode 1 (one IRQ).....	2-7
Mode 2 (two IRQs).....	2-9
Mode 3 (four IRQs).....	2-11
Baud Rate Selection.....	2-12
Serial Line Interface Modules (SLIM).....	2-15
SLIM Installation	2-15
SLIM compatibility.....	2-18
Installing the DFlex-4/104 Adapter in your System	2-18

Chapter 3: Software Installation

Introduction.....	3-1
Configuration	3-1
DOS 3.XX - 6.XX.....	3-1
Linux.....	3-2
Multiuser DOS 7 GOLD	3-2
OS/2.....	3-2
QNX 2.XX.....	3-2
QNX 4.XX.....	3-3
SCO Unix.....	3-3
Windows 3.XX	3-3
Windows 95/98.....	3-3
Windows NT.....	3-4
Utilities	3-4
Portfind	3-4
Porttest.....	3-4
SeePORT	3-4

Chapter 4: Appendices

Appendix A: Specifications.....	4-1
Operating Environment.....	4-1
Power Requirements	4-1
PC Bus Interface	4-1
Communications	4-1
Control Signals	4-2
Dimensions.....	4-2
Connectors/Interface	4-2
Part Numbers	4-2
Certification	4-2
Appendix B: Connectors/Pinouts	4-3
Port Connector Pinouts	4-3
Cable Connector Pinouts	4-4
Power Connector Pinouts	4-5
SLIM Pinouts	4-6
Appendix C: Factory Settings	4-7
I/O/Status Port Address Setting	4-7
IRQ Setting	4-8
Baud Rate Setting	4-9
Appendix D: SLIM Insertion/Removal.....	4-11
SLIM insertion	4-11
SLIM removal.....	4-12
Appendix E: RS-232 SLIM Option.....	4-13
Installation	4-15
Appendix F: RS-485/422 Options.....	4-17
Installation	4-17
RS-485/422 SLIM	4-18
RS-485/422 Cable Wiring	4-21
Appendix G: RS-423 Options.....	4-23
Installation	4-24
RS-423 Cable Wiring	4-26
Appendix H: 20mA Current Loop Option.....	4-27
Installation	4-27
20mA Current Loop SLIM	4-28
Current Loop Cable Wiring	4-31

List of Tables

Table 1: Typical port address usage.....	2-2
Table 2: Port address settings	2-5
Table 3: Baud rates	2-14
Table 4: 10 pin port header pinouts	4-3
Table 5: DB-9 cable connector pinouts	4-4
Table 6: Power connector pinouts	4-5
Table 7: SLIM pinouts	4-6
Table 8: SLIM pinouts	4-16
Table 9: SLIM pinouts	4-20
Table 10: SLIM pinouts	4-25
Table 11: SLIM pinouts	4-30

List of Figures

Figure 1: DFlex-4/104 adapter.....	1-4
Figure 2: DFlex-4/104 - 16 port configuration	1-5
Figure 3: Problem summary sheet.....	1-7
Figure 4: Port address (SW1).....	2-4
Figure 5: IRQ jumper & switch blocks	2-6
Figure 6: Baud rate jumper block (J1).....	2-13
Figure 7: SLIM socket to serial port relationship.....	2-16
Figure 8: I/O/Status port address factory settings	4-7
Figure 9: IRQ factory setting.....	4-8
Figure 10: Baud rate factory setting (J1)	4-9
Figure 11: SLIM insertion.....	4-11
Figure 12: SLIM removal.....	4-12
Figure 13: RS-232; RS-232/Fast SLIM: partial schematic	4-14
Figure 14: RS-485/422 SLIM partial schematic	4-19
Figure 15: RS-485/422 wiring diagram (4 wire).....	4-21
Figure 16: RS-485/422 wiring diagram (2 wire).....	4-21
Figure 17: RS-423 SLIM partial schematic.....	4-23
Figure 18: RS-423 wiring diagram (4 wire).....	4-26
Figure 19: RS-423 wiring diagram (all wire).....	4-26
Figure 20: 20mA Current Loop SLIM schematic	4-28
Figure 21: Current Loop wiring diagram (4 wire).....	4-31

Chapter 1: Introduction

Introduction.....	1-1
Manual Overview.....	1-1
Conventions & Symbols	1-2
Product Overview.....	1-3
DFlex-4/104 Adapter.....	1-3
DFlex-4/104 Software	1-6
Customer Service Overview.....	1-6
RMA Overview.....	1-9

Introduction

This section contains an overall description of the DFlex-4/104 manual, the DFlex-4/104 product, Connect Tech 's technical services, Return Merchandise Authorization and warranty repair policies. The organization of the information is as follows:

- Manual Overview - describes the structure of the manual and the conventions the manual uses.
- Product Overview - describes the DFlex-4/104, its features and specifications.
- Customer Services Overview - describes the various customer support services available to users of Connect Tech products.
- RMA Overview - describes the RMA policy and procedures for all Connect Tech products.

Manual Overview

The purpose of the DFlex-4/104 User's Manual is to help you install the DFlex-4/104 as effortlessly as possible. The manual includes four main sections:

- Introduction - the section you are currently reading, covers the DFlex-4/104 features; Connect Tech's customer services; and return merchandise authorization (RMA) policies and procedures.
- Hardware Installation - describes installation of the DFlex-4/104 adapter.
- Software Installation - discusses the installation of the DFlex-4/104 under various operating systems.

Note:

*We recommend that you read both the **Hardware Installation** and **Software Installation** sections before you attempt to install the DFlex-4/104 adapter.*

- Appendices - the appendices contain information on electrical pinouts, product specifications such as power requirements; default jumper settings; and other technical information.

Conventions & Symbols

This manual uses the following conventions:

- In most cases the font for file names and command statements is **Arial Narrow Bold 9 point** . An example is:

DEVICE=DFLEX.SYS p=200 p=208 p=210 p=218

- *Note: the "Note" convention informs you of important messages, exceptions, or special cases.*

- *Example: the "Example" convention outlines hardware and software installation examples.*

- *Technical Tip: the "Technical Tip" convention offers technical tips to assist you in hardware and software installation or problems*

WARNING

The "Warning" convention advises you to take certain precautions in order to avoid possible damage to your Connect Tech product.



This message warns you that your Connect Tech product is very sensitive to static electricity. Make sure that before handling the product you practice proper ESD procedures.

Product Overview

The DFlex-4/104 adapters are high performance multi-port serial adapters in a PC/104 form factor that allow you to connect up to 4 serial devices.

Your DFlex-4/104 product consists of the following components:

- DFlex-4/104 adapter
- DFlex-4/104 DOS device drivers
- DFlex-4/104 Windows 95/98 device drivers

Note: You can also order standard cables for the DFlex-4/104

DFlex-4/104 Adapter

DFlex-4/104 adapters provide the high speed interfaces between a host computer and multiple external serial devices. DFlex-4/104 adapters include features such as:

- 4 asynchronous serial ports.
- RS-232, RS-485/422, RS-423, or 20mA Current Loop interfaces. Electrical interfaces are on Serial Line Interface Modules (SLIM) and are field upgradeable.
- multiple DFlex-4/104 adapters may reside in a system.
- 16C654 quad UARTs are used to control each port. The 16C654 quad UART has 64 byte transmit and receive FIFO for each port and automatic software/hardware flow control.
- each port has independent baud rate selection offering baud rates from 50 – 460.8 KBPS, with 5, 6, 7 or 8 data bits and 1, 1.5, 2 stop bits, odd or even parity.
- on board switches allow the selection of 8 predefined I/O address sets.
- on board jumpers allow the selection of 1, 2 or 4 IRQ lines. You can choose from interrupts 3, 4, 5, 6, 7, 9/2, 10, 11, 12, 14 and 15.
- optional +5V on serial port headers to power external devices.
- driver support for Windows 95/98/NT. Also compatible with operating systems featuring 16450/16550 serial drivers such as: Linux, BSD/OS, QNX, DOS, Solaris, OS/2 (3RD party driver) and SCO Unix

Figure 1 shows the locations of various hardware components of the DFlex-4/104 adapter.

Figure 1: DFlex-4/104 adapter

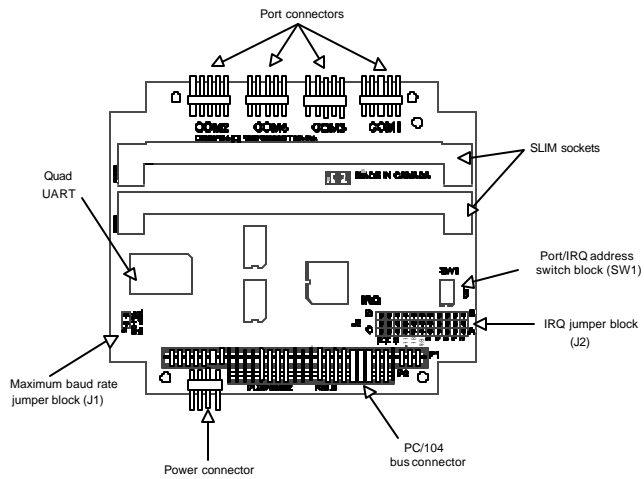

The DFlex-4/104 adapters can accommodate both small and large multi-channel applications. You can combine DFlex-4/104 adapters in a single system. **Figure 2** below represents a sample configuration for a system requiring 16 ports.

Figure 2: *DFlex-4/104 - 16 port configuration*

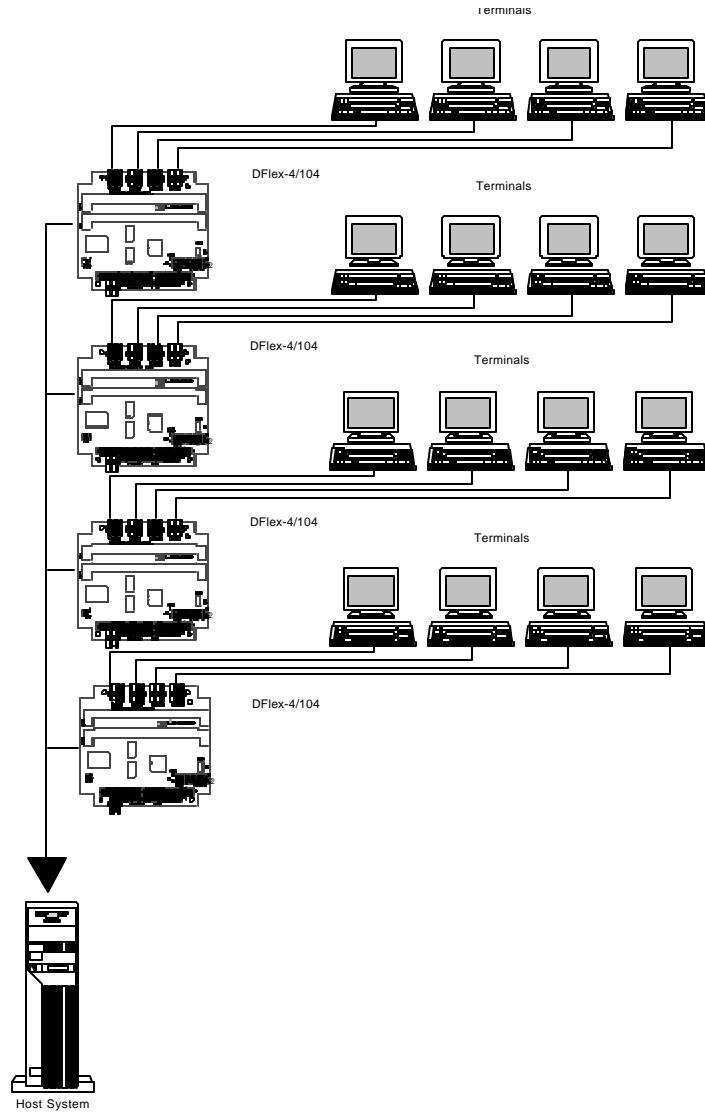

DFlex-4/104 Software

To install your DFlex-4/104 adapter under different operating systems see **Chapter 3: Software Installation**.

Customer Service Overview

If you experience difficulties after reading the manual and using the product, contact the Connect Tech reseller from which you purchased the product. In most cases the reseller can help you with product installation and difficulties.

In the event that the reseller is unable to resolve your problem, our highly qualified support staff can assist you. Please refer to and complete the problem summary sheet found in **Figure 3** before contacting us.

Figure 3: *Problem summary sheet*

Problem Description	
Connect Tech Product Description	
Product:	Revision no.:
Product serial no.:	No. of serial ports:
IRQ selected:	Base address selected:
I/O port address selected:	
Device driver:	Revision no.:
System Description	
Operating system:	Revision no.:
System type & manufacturer:	
Amount of RAM:	CPU type/speed:
Video adapter:	Settings:
Network adapter:	Settings:
Hard disk adapter:	Settings:
Tape adapter:	Settings:
Other serial adapters	Settings:
Other adapters:	Settings:
Devices connected to ports:	

We offer three ways for you to contact us:

Mail/Courier

You may contact us by letter and our mailing address for correspondence is:

Connect Tech Inc.
c/o Customer Service
727 Speedvale Avenue West
Guelph, Ontario
Canada N1K 1E6

Email/Internet

You may contact us through the Internet. Our addresses on the Internet are:

sales@connecttech.com
support@connecttech.com
ftp.connecttech.com
www.connecttech.com/support/support.html

Note:

1. *You can submit your technical support questions to our customer support engineers via our Internet email address*
OR
2. *You can refer to our knowledge database found in the Customer Support section of our World Wide Web site.*
OR
3. *You can fill out the problem summary form, found in the Customer Support section of our World Wide Web site and submit it to our customer support engineers via the Web.*
OR
4. *You can obtain the latest versions of software drivers and manuals from the Customer Support section of our World Wide Web site or from the /pub section on our FTP site.*

Telephone/Facsimile

Customer Support representatives are ready to answer your call Monday through Friday, from 9:00 a.m. to noon and 1:00 p.m. to 5:00 p.m. Eastern Standard Time. Our numbers for calls are:

Telephone: 519-836-1291
Toll Free: 1-800-426-8979
Facsimile 519-836-4878 (on-line 24 hours)

RMA Overview

Connect Tech products requiring warranty or non-warranty repairs need an RMA number. To obtain a Return Merchandise Authorization (RMA) Number please contact:

Connect Tech Inc.
Technical Support
727 Speedvale Ave. West
Guelph, Ontario
Canada N1K 1E6
Phone: (519) 836-1291
Toll Free: 1-800-426-8979
Facsimile: (519) 836-4878
Email: support@connecttech.com
FTP: ftp.connecttech.com
URL: <http://www.connecttech.com/support/support.html>

Include with the product, proof of purchase (including date of purchase), a description of the problem and the RMA number. Clearly display the RMA number on the external packaging. Please refer to the Limited Warranty for further restrictions or requirements.



Your DFlex adapter is very sensitive to static electricity. Make sure that before you remove the card from your computer, you wear an anti-static wristband. When you remove the board from your computer, handle it only by the edges and place it on the anti-static bag or an anti-static mat.

Note:

- 1. Please pack the item for repair securely and ship it prepaid and insured. Connect Tech is not liable for damage or loss to the product due to shipping.***
- 2. Connect Tech will not accept items for repair without an RMA number.***
- 3. Connect Tech will not accept items for repair shipped freight collect.***

Chapter 2: Hardware Installation

Introduction.....	2-1
Configuration	2-1
Port Addresses	2-2
Status Port Addresses	2-3
Custom Port Addresses.....	2-4
Interrupt Selection.....	2-6
Mode 1 (one IRQ).....	2-7
Mode 2 (two IRQs).....	2-9
Mode 3 (four IRQs).....	2-11
Baud Rate Selection.....	2-12
Serial Line Interface Modules (SLIM).....	2-15
SLIM Installation	2-15
SLIM compatibility.....	2-18
Installing the DFlex-4/104 Adapter in your System	2-18

Introduction

Hardware installation involves configuration of the DFlex-4/104 adapter. The following sections detail how to change the field configurable parameters. The setting of these will depend on both the number of boards you are installing and the existing configuration of your system.

Note: Please refer to **Chapter 3: Software Installation** for installation of your DFlex-4/104 board under certain operating systems.

Configuration

You must configure various settings and options before installing your DFlex-4/104 adapter in your system. In order to insure a successful installation, please follow the steps in the order specified below.

1. Selection of I/O and status port addresses.
2. Selection of IRQs.
3. Baud rate selection.
4. Serial Line Interface Module (SLIM) options.
5. Installation of Serial Line Interface Modules (SLIM).
6. Configuration of RS-232 and/or RS-485/422 and/or RS-423 and/or Current Loop options.
7. Installing the DFlex-4/104 adapter in your system.



Your DFlex-4/104 adapter is very sensitive to static electricity. Make sure that before you remove the card from the anti-static shipping bag, you wear an anti-static wristband. When you remove the board from the anti-static bag, handle it only by the edges and place it on the anti-static bag or an anti-static mat.

Port Addresses

Port addresses are configured with the DIP switch block SW1 situated near the PC/104 bus connector on the DFlex-4/104 adapter. DIP switches 1, 2, and 3 select a set of port addresses for the ports while DIP switch 6 enables or disables a specific status port address for that set of addresses. Please refer to **Figure 4** for a description and location of the switch block, while **Table 2** provides the switch settings for the various port address sets.

However many other devices may require port addresses in your computer's I/O address space. In most cases the factory setting is sufficient, but when there is a conflict, SW1 may require a different setting. **Table 1** summarizes typical I/O port address usage.

WARNING

Do not use a pencil to set the DIP switches as the lead graphite may short-circuit the switch.

Table 1: Typical port address usage

Port Address (Hex)	Usage
000 - 0FF	Reserved
170 - 177	Fixed disk controller (primary)
1F0 - 1F7	Fixed disk controller (secondary)
200 - 207	Game port
278 -27F	Parallel port (LPT2)
2C0 - 2CF	EGA video adapter (#2)
2F8 - 2FF	Asynchronous serial port (COM2)
360 - 36F	Parallel port (LPT1)
370 - 377	Floppy disk controller (secondary)
378 - 37F	Parallel port (LPT1)
380 - 38F	SDLC adapter (#2)
3A0 - 3AF	SDLC adapter (#1)
3B0 - 3BF	Video adapters
3F0 - 3F7	Floppy disk controller (primary)
3F8 - 3FF	Asynchronous serial port (COM1)

Status Port Addresses

Some operating system device drivers can utilize an Interrupt Status Port, for example Windows NT offers it as an option and for SCO Unix it is mandatory. This can improve your system's efficiency. The DFlex-4/104 offers a status port and this port is enabled and disabled using DIP switch 6 on switch block SW1. When DIP switch 6 is in the **on** position the status port is enabled and when it is in the **off** position it is disabled. Please refer to **Table 2** for a list of supported status port addresses and to **Figure 4** for a description and location of switch block SW1

Technical tip:

*You should set DIP switch 6 on switch block SW1 to the **off** position if you are not using the status port for your application. This eliminates the possibility of an address conflict with another device in your system.*

Custom Port Addresses

You can generate other port addresses by making changes to the PALs found on the DFflex-4/104 adapter. If you require specific port addresses not listed in **Table 2** please contact the Connect Tech sales department for further information.

Figure 4: Port address (SW1)

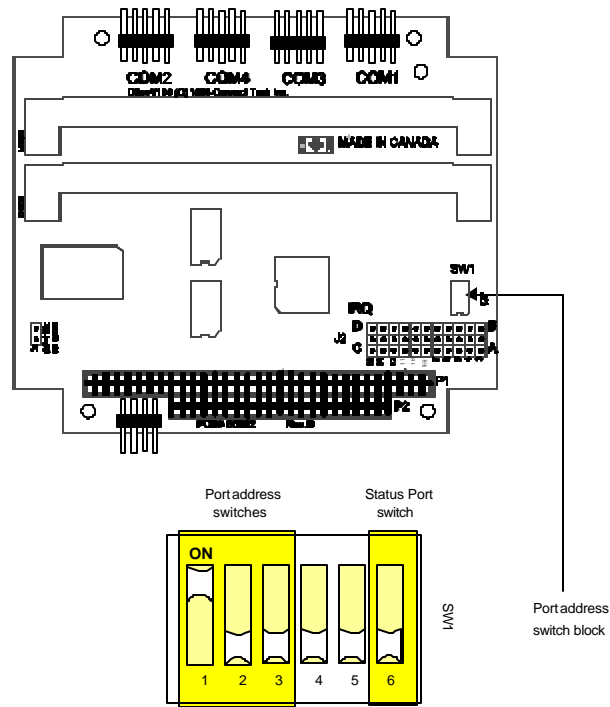

Table 2: Port address settings

DIP switch			Ports				Status
1	2	3	1	2	3	4	
off	off	off	2F8	3F8	340	348	350
off	off	on	300	308	310	318	320
off	on	off	280	288	290	298	2A0
off	on	on	240	248	250	258	260
on	off	off	200	208	210	218	220
on	off	on	190	198	1A0	1A8	1B0
on	on	off	140	148	150	158	160
on	on	on	100	108	110	118	120

Note: Port addresses are expressed in hex

Examples:

- The following example shows the port address jumper block set for the factory setting of port addresses 200, 208, 210, 218 (hex) and status port disabled

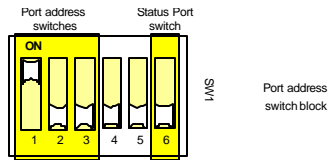

- The following example shows the port address jumper block set for port addresses 2F8, 3F8, 340, 348 (hex) and status port disabled.

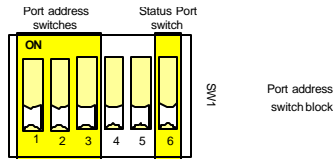

- The following example shows the port address jumper block set for port addresses 240, 248, 250, 258 (hex) and status port 260 (hex) enabled.

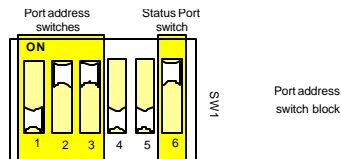

Interrupt Selection

You can configure an interrupt request line (IRQ) with the jumper block J2 and DIP switches 4 and 5 on switch block SW1 situated near the PC/104 bus connector on the DFlex-4/104 adapter. Please refer to **Figure 5** for a description and location of the jumper block J2 and switch block SW1.

Figure 5: IRQ jumper & switch blocks

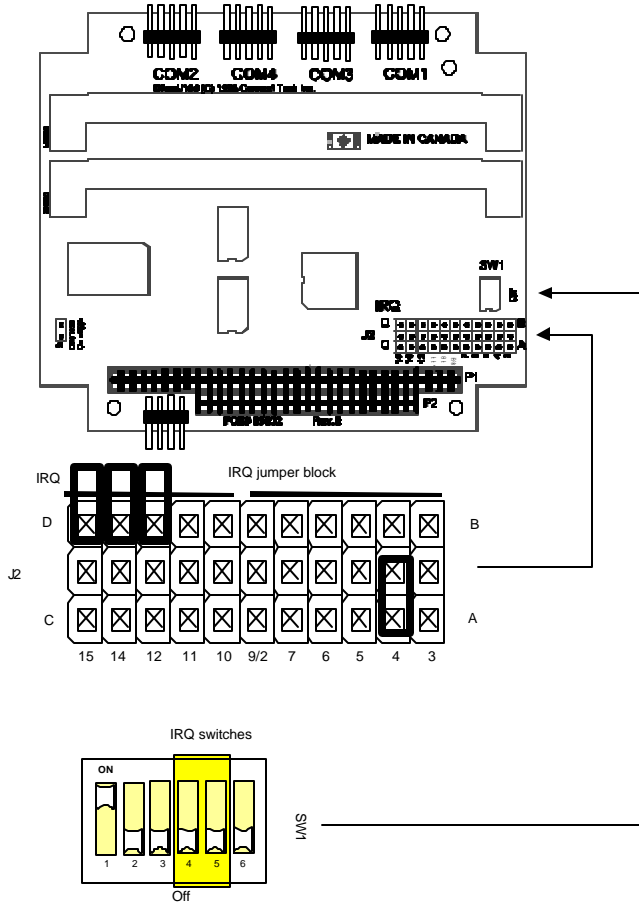

You are able to configure the DFlex-4/104 adapter for three different IRQ modes.

- n **Mode 1 (one IRQ):** all ports interrupting on one IRQ
- n **Mode 2 (two IRQs):** odd ports (ports 1 and 3) interrupt on one IRQ and even ports (ports 2 and 4) interrupt on another IRQ
- n **Mode 3 (four IRQs):** each port interrupts on it's own interrupt

Mode 1 (one IRQ)

Mode 1 allows you to select one IRQ for all ports. This mode is recommended for most installations. Please follow these steps to choose this mode:

1. Choose an available IRQ you wish the ports to interrupt on.
2. Make sure that switch block SW1 has DIP switches 4 and 5 in the **off** position.
3. Install a jumper across the corresponding IRQ pins on the A/C row and the middle row of jumper block J2.
4. Ensure that all other jumpers on J2 are removed or not contacting more than one pin.

Examples:

- The following example shows the settings on J2 and SW1 so that all ports will interrupt on the factory setting of IRQ 4.

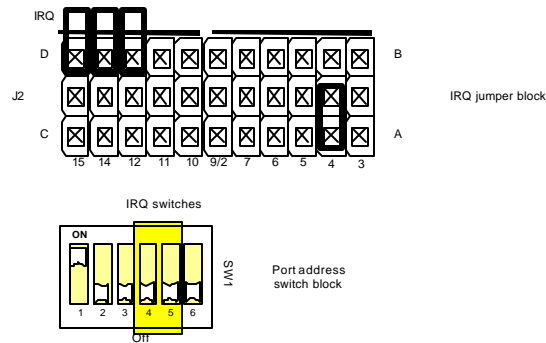

- The following example shows the settings on J2 and SW1 so that all ports will interrupt on IRQ 10.

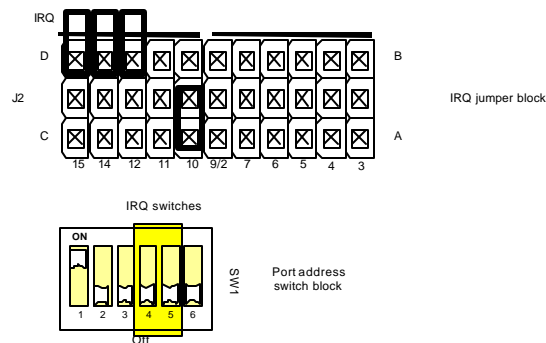

Note: Ensure that all other unused jumpers on J2 are removed or not contacting more than one pin.

Mode 2 (two IRQs)

Mode 2 allows you to select one IRQ for ports 1 and 3, and another IRQ for ports 2 and 4. Please follow these steps to choose this mode:

1. Choose an available IRQ for ports 1 and 3 and an available interrupt for ports 2 and 4 .
2. Make sure that switch block SW1 has DIP switch 4 in the **on** position and DIP switch 5 in the **off** position.
3. Install a jumper across the corresponding IRQ pins on the A/C row and the middle row of jumper block J2 for ports 1 and 3. Then install a jumper across the corresponding IRQ pins on the B/D row and the middle row of jumper block J2 for ports 2 and 4.
4. Ensure that all other unused jumpers on J2 are removed or not contacting more than one pin.

Examples:

- The following example shows the settings on J2 and SW1 so that ports 1 and 3 will interrupt on IRQ 7 and ports 2 and 4 will interrupt on IRQ 12.

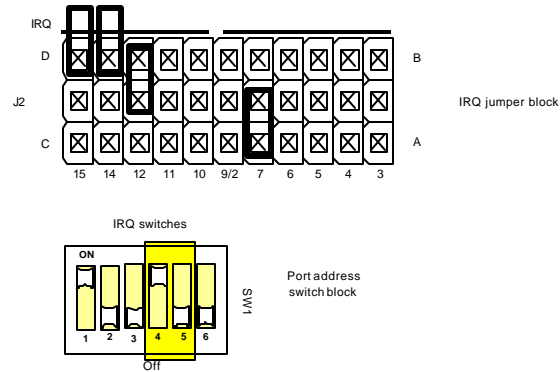

- The following example shows the settings on J2 and SW1 so that ports 1 and 3 will interrupt on IRQ 10 and ports 2 and 4 will interrupt on IRQ 15.

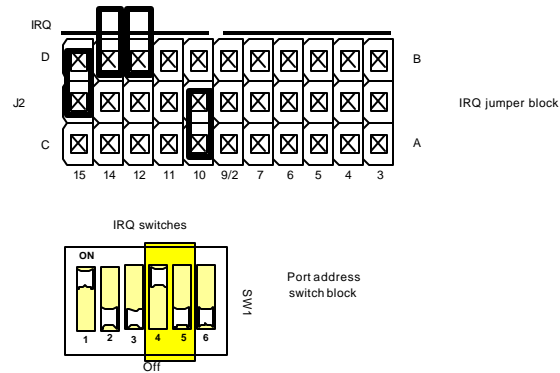

Note: Ensure that all other unused jumpers on J2 are removed or not contacting more than one pin.

Mode 3 (four IRQs)

Mode 3 allows you to select a unique IRQ for each port. Please follow these steps to choose this mode:

1. Choose available and unique IRQs for ports 1, 2, 3 and 4.
2. Make sure that switch block SW1 has DIP switch 4 in the **off** position and DIP switch 5 in the **on** position.
3. Please take note of the two solid white lines just above jumper block J2. These lines mark the **A, B, C** and **D** portions of the corresponding row of jumper pins.
4. First install a jumper across an IRQ pin on the **A** portion of J2 and the corresponding pin in the middle row of J2 for port 1.
5. Next install a jumper across an IRQ pin on the **B** portion of J2 and the corresponding pin in the middle row of J2 for port 2.
6. Then install a jumper across an IRQ pin on the **C** portion of J2 and the corresponding pin in the middle row of J2 for port 3.
7. Finally install a jumper across an IRQ pin on the **D** portion of J2 and the corresponding pin in the middle row of J2 for port 4.
8. Ensure that all other unused jumpers on J2 are removed or not contacting more than one pin.

Note:

In Mode 3, ports 1 and 2 are limited to IRQs 3 to 9/2 and ports 3 and 4 are limited to IRQs 10 to 15

Examples:

1. The following example shows the settings on J2 and SW1 so that port 1 interrupts on IRQ 5, port 2 interrupts on IRQ 7, port 3 interrupts on IRQ 10 and port 4 interrupts on IRQ 15.

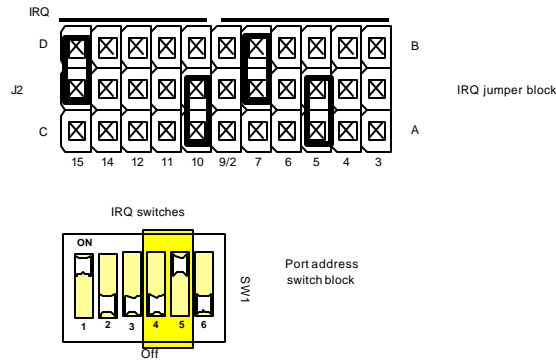

2. The following example shows the settings on J2 and SW1 so that port 1 interrupts on IRQ 5, port 2 interrupts on IRQ 7, port 3 interrupts on IRQ 12 and port 4 interrupts on IRQ 15.

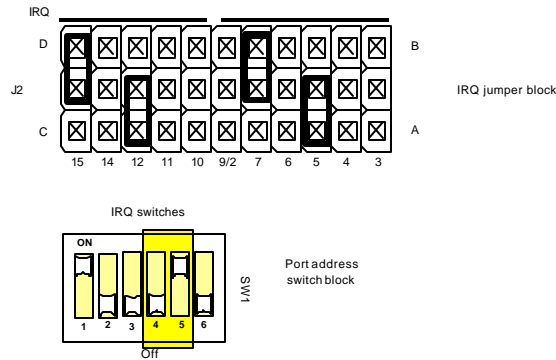

Note: Ensure that all other unused jumpers on J2 are removed or not contacting more than one pin.

Baud Rate Selection

The DFlex-4/104 is a high-speed serial adapter for PC/104 bus compatible computers. Utilizing large FIFO buffers in the 16C654 quad UART and high-speed circuitry, the DFlex-4/104 adapter is an ideal solution for applications requiring serial communications up to 460K baud.

The DFlex4/104 is capable of baud rates up to 460.8 kbps (4X oscillator) or 115.2 kbps (1X oscillator) depending on the position of jumper J1. If the jumper is in the **off** position (default) during a hardware reset, the maximum baud rate will be 115.2 kbps. However if the jumper is in the **on** position during a hardware reset the maximum baud rate will be 460.8 kbps. Please refer to **Figure 6** for a description and location of the jumper block J1.

Figure6: Baud rate jumper block (J1)

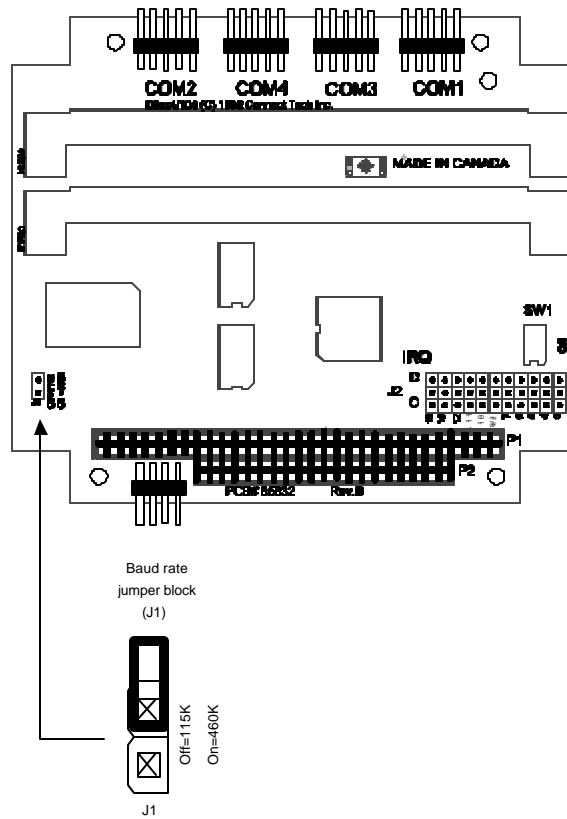

The purpose of the jumper is to provide compatibility with device drivers that won't select the desired baud rates if the DFlex4/104 is set for 460.8 kbps. For example most serial drivers expect a maximum baud rate of 115.2 kbps (or a 1X oscillator), however if you set the DFlex4/104 at 460.8kbps (4X oscillator) then you have selected a baud rate that is **FOUR TIMES FASTER!** Please refer to **Table 3** for a list of standard and extended baud rates for the DFlex-4/104.

Note:

Some device drivers actually autodetect or allow the user to specify the oscillator frequency in order to select the desired baud rate correctly:

- n *The Connect Tech Windows95 driver Control Panel Applet has a selection for DFlex/Fast or DFlex-4/104.(Manual)*
- n *The OS2 driver from Ray Gwinn (SIO) autodetects the oscillator. (Automatic)*
- n *The QNX4 driver Dev.ser allows the user to specify what divisor to use. Selected with the -y paramter.*
- n *The OS2 driver from OS/tools Inc autodetects the oscillator. (Automatic)*

Table 3: Baud rates

Standard Baud Rate. (1X - set in software) Jumper off J1	Max. Baud Rate (4X standard) Jumper on J1
50	200
75	300
150	600
300	1200
600	2400
1200	4800
2400	9600
4800	19.2k
7200	28.8k
9600	38.4k
19.2k	76.8k
38.4k	153.6k
57.6k	230.4k
115.2K	460.8K

Serial Line Interface Modules (SLIM)

The DFlex-4/104 adapter accepts interchangeable electrical line interfaces. These Serial Line Interface Modules (SLIM) provide the electrical interface for two asynchronous communication ports. If you order RS-232 or RS-232/Fast modules please refer to **Appendix E: RS-232 Option** for more technical information. If you order RS-485/422 modules please refer to **Appendix F: RS-485/422 Option** for more technical information. If you order RS-423 modules please refer to **Appendix G: RS-423 Option** for more technical information. If you order 20mA current loop modules please refer to **Appendix H: 20mA Current Loop Option** for more technical information.

SLIM Installation

The DFlex-4/104 adapter has two sockets that accept Serial Line Interface Modules (SLIM). Each SLIM provides the RS-232 or RS-485/422 or RS-423 or 20mA current loop receivers and transmitters to condition two serial ports. SLIM socket 1 interfaces ports 1 and 2. SLIM socket 2 interfaces ports 3 and 4. Please refer to **Figure 7** for the SLIM socket to serial port relationship.

WARNING

You must insert Serial Line Interface Modules into all of the SLIM sockets to attain the communications functionality of your DFlex-4/104 adapter.

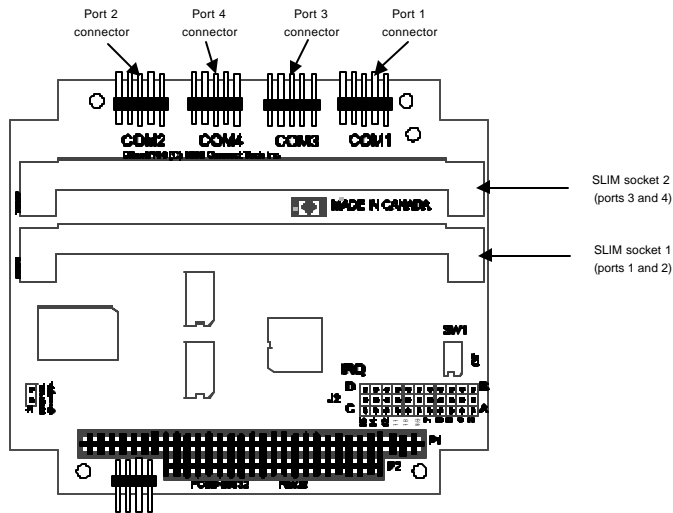
Figure 7: *SLIM socket to serial port relationship*

To insert a SLIM into its connector follow these steps:

1. Place the SLIM into the socket almost vertically (about a 75 degree angle), making sure to align it properly before inserting it into the socket.
2. Press downward and sideways on the SLIM until it latches into the socket. **Do NOT force the SLIM**, the installation process requires a small amount of force and should be very smooth and easy. If you experience resistance, check the alignment and insertion depth of the SLIM. Refer to **Appendix D: SLIM Insertion/Removal** regarding the insertion of a SLIM.

To remove a SLIM from its connector follow these steps:

1. Using both hands, place your thumbs on the clips that hold the SLIM into the socket, and place your index fingers on the edge of the SLIM.
2. Push outwards (with your thumbs) on the clips until you release the SLIM from the clips. Your index fingers can then raise the SLIM past the clips. You can then remove the SLIM from the DFlex-4/104 adapter. The force required to open the clips is small and the SLIM naturally springs upwards when the clips are open wide enough. If removal is difficult, then you are probably trying to raise the SLIM before the clips are open. Refer to **Appendix D: SLIM Insertion/Removal** regarding the removal of a SLIM.



The RS-232, RS-232/Fast, RS-485/422, RS-423 and 20mA current loop SLIMs are very sensitive to static electricity. Make sure you wear an anti-static wristband before you remove the SLIMs from the anti-static shipping bag. When you remove the board from the anti-static bag, handle it only by the edges and place it on the anti-static bag or an anti-static mat.

SLIM compatibility

Some of the standard SLIM modules cannot take advantage of the faster baud rates available with a DFlex-4/104 is set for 460.8 Kbps. The following SLIM modules are compatible with a DFlex-4/104 adapter set for 460k mode on J1:

SLIM	Part Number	115K Mode	460K Mode
RS-232/Fast	SIMM-F232	Yes	Yes
RS-232	SIMM-RS232	Yes	No
RS-485/422	SIMM-RS485	Yes	Yes
RS-423	SIMM-RS423	Yes	Yes
20mA current loop	SIMM-20MA	Yes	No

Installing the DFlex-4/104 Adapter in your System

To install your **DFlex-4/104** adapter in your system follow these steps:



Computer components are very sensitive to static electricity. When installing adapters in your computer make sure that you wear an anti-static wristband. Handle the adapter by its edges and place it on the anti-static bag or an anti-static mat.

1. Turn the power off to your system.
2. Open your system to expose the PC/104 bus connector (consult the system documentation for information on this procedure.)
3. Place the DFlex-4/104 adapter in the bus connector and push down gently until the card seats in the connector.

***Note:** Do not force the card into the bus connector. If you meet a great deal of resistance remove the board and try again.*

4. Secure the DFlex-4/104 adapter with the appropriate fasteners or spacers (consult the system documentation for information on this procedure).
5. Close your system.

Chapter 3: Software Installation

Introduction.....	3-1
Configuration	3-1
DOS 3.XX - 6.XX.....	3-1
Linux.....	3-2
Multiuser DOS 7 GOLD	3-2
OS/2.....	3-2
QNX 2.XX.....	3-2
QNX 4.XX.....	3-3
SCO Unix.....	3-3
Windows 3.XX	3-3
Windows 95/98.....	3-3
Windows NT.....	3-4
Utilities	3-4
Portfind	3-4
Porttest.....	3-4
SeePORT.....	3-4

Introduction

The DFlex-4/104 is a standard multi-port serial adapter in a PC/104 format that utilizes 16C654 quad UARTS. In many cases, users have software that will interface directly to the DFlex-4/104. Many operating systems are equipped with device drivers to control access to multiple 16550 style UARTS. This section covers configurations for the following operating systems:

- DOS 3.XX - 6.XX
- Linux
- Multiuser DOS 7 GOLD
- OS/2
- QNX 2.XX
- QNX 4.XX
- SCO Unix
- Windows 3.XX
- Windows 95/98
- Windows NT

Note:

Your DFlex-4/104 adapter may ship with diskettes that include README files. Please examine these files for technical tips or release notes concerning installation and configuration of various device drivers and software utilities. If you require more information please contact Connect Tech Customer Service.

Configuration

The following sections detail some recommended configurations for the DFlex-4/104 running under various operating systems. These settings will depend on both the number of boards being installed and the existing configuration of your PC.

The configuration steps that must be considered are:

- port addresses
- interrupt request lines

DOS 3.XX - 6.XX

Many DOS applications are designed to directly control the hardware of 16550 style UART. For some applications, the DOS device driver provided with the DFlex-4/104 will help to integrate the extra communication ports quickly and easily into the system. Please refer to the DOS.TXT file on the DFlex-4/104 distribution diskette for more information about the DOS driver.

Linux

Linux is a leading multi-user, multi-tasking operating system for Intel based personal computers. Linux and its standard serial driver allow users to configure their computer systems with multiple serial ports sharing one IRQ.

Please contact Connect Tech Customer Support about installing the DFflex-4/104 for the Linux operating system.

Multuser DOS 7 GOLD

Multuser DOS 7 GOLD is a multi-user, multi-tasking operating system for Intel based personal computers. Multuser DOS 7 GOLD and its standard serial driver allow users to configure their computer systems with multiple serial ports sharing one IRQ.

Please refer to the **MULTDOS7.TXT** file on the DFflex-4/104 distribution diskette for more information about installing the DFflex-4/104 for the Multuser DOS 7 GOLD operating system.

OS/2

OS/2 is a leading multi-tasking operating system for Intel based personal computers. Please contact Connect Tech Customer Support about installing the DFflex-4/104 for the OS/2 operating system.

QNX 2.XX

QNX 2.XX is a leading multi-user, multi-tasking, realtime operating system for Intel based personal computers and embedded systems. QNX 2.XX and its standard serial driver allow users to configure their computer systems with multiple serial ports sharing one IRQ.

Please refer to the **QNX2.TXT** file on the DFflex-4/104 distribution diskette for more information about installing the DFflex-4/104 for the QNX 2.XX operating system.

QNX 4.XX

QNX 4.XX is a leading POSIX compliant, multi-user, multi-tasking, and realtime operating system for Intel based personal computers and embedded systems. QNX 4.XX and its standard serial driver allow users to configure their computer systems with multiple serial ports sharing one IRQ.

Please refer to the **QNX4.TXT** file on the DFlex-4/104 distribution diskette for more information about installing the DFlex-4/104 for the QNX 4.XX operating system.

SCO Unix

SCO Unix is a leading multi-user, multi-tasking, operating system for Intel based personal computers. SCO Unix and its standard serial driver allow users to configure their computer systems with multiple serial ports sharing one IRQ.

Please contact Connect Tech Customer Support about installing the DFlex-4/104 for the SCO Unix operating system.

Windows 3.XX

Windows 3.XX is a leading operating system for Intel based personal computers. Please refer to the **WIN31.TXT** file on the DFlex-4/104 distribution diskette for more information about installing the DFlex-4/104 for the Windows 3.XX operating system.

Windows 95/98

Windows 95/98 are leading multi-tasking operating systems for Intel based personal computers. Windows 95/98 and its standard serial driver allow users to configure their computer systems with multiple serial ports sharing one IRQ.

Please refer to the **WIN95.TXT** file on the DFlex-4/104 distribution diskette for more information about installing the DFlex-4/104 for the Windows 95/98 operating system.

Windows NT

Windows NT is a leading multi-tasking operating system for Intel based personal computers. Windows NT and its standard serial driver allow users to configure their computer systems with multiple serial ports sharing one IRQ.

Please refer to the **WINNT.TXT** file on the DFlex-4/104 distribution diskette for more information about installing the DFlex-4/104 for the Windows NT operating system.

Utilities

Portfind

Portfind is a utility that verifies the I/O port addresses and IRQs of the serial ports in your system. For more information on the use of Portfind, please refer to the readme file **portfind.txt** on the DFlex-4/104 distribution diskette.

Porttest

Porttest is a utility that performs loopback tests on the RxD, TxD, RTS, CTS, DTR, and DCD signals of the serial ports in your system. For more information on the use of Porttest, please refer to the readme file **porttest.txt** on the DFlex-4/104 distribution diskette.

SeePORT

SeePORT is a full-featured serial data analyzer included with Blue Heat/PCI, DFlex, and DFlex-4/104 adapters. This handy utility enables the user to examine the data associated with any serial port including the modem control signal states. You can quickly identify serial port related support issues using the information gathered by SeePORT.

SeePORT offers the following features:

- tracking of incoming and outgoing data on serial ports
- tracking of all modem control signals on serial ports
- time stamping of displayed events
- real time display of captured data
- continuous and until full modes of capturing

For more information on the use of SeePORT, please refer to the readme file **README.TXT** on the DFlex-4/104 distribution diskette under the SeePORT directory.

Chapter 4: Appendices

Appendix A: Specifications	4-1
Operating Environment	4-1
Power Requirements	4-1
PC Bus Interface	4-1
Communications	4-1
Control Signals	4-2
Dimensions.....	4-2
Connectors/Interface	4-2
Part Numbers	4-2
Certification	4-2
Appendix B: Connectors/Pinouts	4-3
Port Connector Pinouts	4-3
Cable Connector Pinouts	4-4
Power Connector Pinouts	4-5
SLIM Pinouts	4-6
Appendix C: Factory Settings.....	4-7
I/O/Status Port Address Setting.....	4-7
IRQ Setting.....	4-8
Baud Rate Setting.....	4-9
Appendix D: SLIM Insertion/Removal.....	4-11
SLIM insertion.....	4-11
SLIM removal.....	4-12
Appendix E: RS-232 SLIM Option.....	4-13
Installation.....	4-15
Appendix F: RS-485/422 Options	4-17
Installation.....	4-17
RS-485/422 SLIM	4-18
RS-485/422 Cable Wiring.....	4-21
Appendix G: RS-423 Options	4-23
Installation.....	4-24
RS-423 Cable Wiring.....	4-26
Appendix H: 20mA Current Loop Option	4-27
Installation.....	4-27
20mA Current Loop SLIM.....	4-28
Current Loop Cable Wiring.....	4-31

Appendix A: Specifications

Operating Environment

- Storage temperature: -40° C to 150° C
- Operating temperature: 0° C to 70° C

Power Requirements

- **DFlex-4/104 (no Serial Line Interface Module)**
 - +5 VDC +/-5% @ 100 mA (max.)
 - +5 VDC +/-5% @ 400 mA (max.) if using the +5V connections on the COM port headers
- **RS-232 SLIM (no load)**
 - +5 VDC +/- 5% @ 30 mA. typ.
 - +12 VDC +/- 5% @ 1 mA. typ.
- n **RS-232/Fast SLIM (no load)**
 - +5 VDC +/- 5% @ 30 mA. typ.
 - +12 VDC +/- 10% @ 38 mA. typ.
 - 12 VDC +/- 10% @ 36 mA. typ.
- **RS-485/422 SLIM (no load)**
 - +5 VDC +/- 5% @ 120 mA. typ.
- n **RS-423 SLIM (no load)**
 - +5 VDC +/- 5% @ 70 mA. typ.
 - +12 VDC +/- 10% @ 26 mA. typ.
 - 12 VDC +/- 10% @ 26 mA. typ.
- **20mA Current loop SLIM (no load)**
 - +5 VDC +/- 5% @ 30 mA. typ.
 - +12 VDC +/- 5% @ 4 mA. typ.

PC Bus Interface

- PC interrupts are jumper selectable, (2, 3, 4, 5, 6, 7, 9, 10, 11, 12, 14, 15)
- Base address for I/O ports is DIP switch selectable, requires 4 addresses
- One PC/104 expansion connector

Communications

- 16C654 quad UARTs communication controllers
- Programmable baud rate generator - up to 460.8K baud on all ports

Control Signals

- RS-232 RTS; DTR; TxD; DCD; CTS; RxD
- RS-485 RTS; TxD; CTS; RxD
- RS-423 RTS; TxD; CTS; RxD
- 20mA Current Loop TxD; RxD

Dimensions

- *DFlex-4/104*
Length: 11.50 cm (4.55 inches)
Height: 9.58 cm (3.775 inches)

Connectors/Interface

- *DFlex-4/104*
10 pin header connector

Part Numbers

<i>DFlex-4/104</i>	
D4104654XX	DFlex-4/104, 4 port, c/w 16C654 UARTs, unpopulated
D4104654NC	DFlex-4/104, 4 port, c/w 16C654 UARTs, unpopulated, no cable
SIMM-RS232	RS-232 SLIM module
SIMM-F232	RS-232 Fast SLIM module
SIMM-RS485	RS-485 SLIM module
SIMM-RS423	RS-423 SLIM module
SIMM-20MA	Current Loop SLIM module
CAB104	DFlex-4/104 cable c/w male DB9 connector

Certification*DFlex-4/104*

The DFlex-4/104 is to be included into a device ultimately subject to FCC, DOC/IC, and CE certification. The customer is responsible for bringing the completed device into compliance prior to resale.

Appendix B: Connectors/Pinouts

Appendix B outlines the pinouts for the following:

- DFlex-4/104 port connector pinouts
- DFlex-4/104 cable connector pinouts
- DFlex-4/104 power connector pinouts
- SLIM pinouts

Port Connector Pinouts

Tables 4 shows the pinouts for the DFlex-4/104 10 pin port header connectors

Table 4: 10 pin port header pinouts

Pin No.	RS-232 Signal	RS-485 Signal	RS-423 Signal	Current Loop Signal
1	DCD	RxD (+)	RxD (+)	RxD (-)
2	N/C	CTS (-)	CTS (-)	RxD Return
3	RxD	TxD (+)	TxD Ref	TxD (+)
4	RTS	RTS (-)	RTS (-)	TxD (-)
5	TxD	TxD (-)	TxD (-)	TxD Source
6	CTS	RTS (+)	RTS Ref	RxD (+)
7	DTR	RxD (-)	RxD (-)	TxD Return
8	N/C	CTS (+)	CTS (+)	RxD Source
9	SG	SR	SR	SG
10	+5V (if fuse option is installed at location F2)			

Printed circuit board

Cable Connector Pinouts

You can order optional DB9 ribbon cables with the DFlex-4/104. These cables attach to the 10 pin port headers on the board. **Table 5** shows the pinouts for the optional DFlex-4/104 male DB9 cable connectors.

Table 5: DB-9 cable connector pinouts

Pin No.	RS-232 Signal	RS-485 Signal	RS-423 Signal	Current Loop Signal
1	DCD	RxD B(+)	RxD(+)	RxD(-)
2	RxD	TxD B(+)	TxD Ref	TxD(+)
3	TxD	TxD A(-)	TxD(-)	TxD Source
4	DTR	RxD A(-)	RxD(-)	TxD Return
5	SG	SR	SR	SG
6	N/C	CTS A(-)	CTS(-)	RxD Return
7	RTS	RTS A(-)	RTS(-)	TxD(-)
8	CTS	RTS B(+)	RTS Ref	RxD(+)
9	N/C	CTS B(+)	CTS(+)	RxD Source

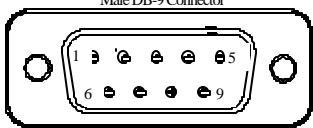

Male DB-9 Connector

Technical Tip:

Please ensure that you terminate the DCD or CTS signals if your application does not use them. The common way to do this is to connect DCD to DTR and/or to connect CTS to RTS. Failure to do so may result in a loss of a performance on your DFlex-4/104 adapter.

Power Connector Pinouts

Table 6 shows the pinouts for the DFlex-4/104 8 pin power header connector

Table 6: *Power connector pinouts*

Pin No.	Description
1	GND
2	+5V
3	+5V
4	+12V
5	N/C
6	-12V
7	GND
8	+5V

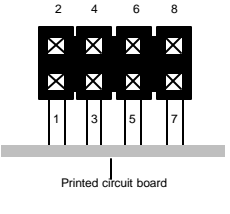

The diagram shows a top-down view of the 8-pin power header connector. The pins are arranged in two rows of four. The top row pins are labeled 2, 4, 6, and 8 from left to right. The bottom row pins are labeled 1, 3, 5, and 7 from left to right. Each pin is represented by a black square with a white 'X' inside. The header is connected to a grey horizontal bar representing the printed circuit board.

SLIM Pinouts

Table 7 shows the pinouts for the Connect Tech Serial Line Interfaces Modules.

Table 7: *SLIM pinouts*

SLIM Pin No.	TIL Signal	RS-232 Signal	RS-485 Signal	RS-423 Signal	Current Loop Signal
1	N/C				
2		RTS 1	RTS A(-) 1	RTS (-) 1	TxD(-) 1
3		TxD 1	TxD A(-) 1	TxD (-) 1	TxD Source 1
4		CTS 1	RTS B(+) 1	RTS Ref 1	RxD(+) 1
5		RxD 1	TxD B(+) 1	TxD Ref 1	TxD(+) 1
6		N/C	CTS A(-) 1	CTS A(-) 1	RxD Return 1
7		DTR 1	RxD A(-) 1	RxD A(-) 1	TxD Return 1
8		N/C	CTS B(+) 1	CTS B(+) 1	RxD Source 1
9		DCD 1	RxD B(+) 1	RxD B(+) 1	RxD(-) 1
10		RTS 2	RTS A(-) 2	RTS (-) 2	TxD(-) 2
11		TxD 2	TxD A(-) 2	TxD (-) 2	TxD Source 2
12		CTS 2	RTS B(+) 2	RTS Ref 2	RxD(+) 2
13		RxD 2	TxD B(+) 2	TxD Ref 2	TxD(+) 2
14		N/C	CTS A(-) 2	CTS A(-) 2	RxD Return 2
15		DTR 2	RxD A(-) 2	RxD A(-) 2	TxD Return 2
16		N/C	CTS B(+) 2	CTS B(+) 2	RxD Source 2
17		DCD 2	RxD B(+) 2	RxD B(+) 2	RxD(-) 2
18	Ground				
19	+12 V				
20	-12 V				
21	+5 V				
22	DCD 2		Tied high	Tied high	Tied high
23	CTS 2				Tied high
24	RTS 2				
25	DTR 2				
26	TxD 2				
27	RxD 2				
28	RxD 1				
29	TxD 1				
30	DTR 1				
31	RTS 1				
32	CTS 1				Tied high
33	DCD 1		Tied high	Tied high	Tied high
34	TC				
35	RC				

Note: *earlier versions of the current loop SLIM have pins 22, 23, 32, and 33 tied low.*

Appendix C: Factory Settings

Appendix C summarizes the following factory settings for the DFlex-4/104 adapter.

- I/O Port address setting
- IRQ (Interrupt Request Line)

I/O/Status Port Address Setting

Switch block S1 sets the I/O and status port addresses for the DFlex-4/104 adapter. Connect Tech ships the DFlex-4/104 adapter with S1 set for I/O port addresses 200, 208, 210, 218 hex and the status port disabled. **Figure 8** shows the location and factory setting of this jumper block.

Figure 8: I/O/Status port address factory settings

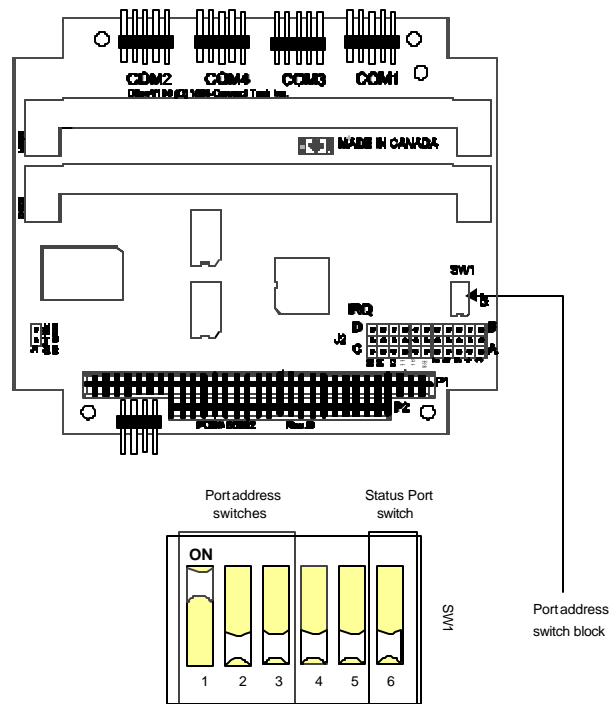

IRQ Setting

Jumper block J2 along with DIP switches 4 and 5 on switch block SW1 sets the IRQ line for the DFlex-4/104 adapter. Connect Tech ships the DFlex-4/104 with a shorting block installed across pins to set all ports to interrupt on IRQ 4. **Figure 9** shows the location and factory setting of jumper block J2 and switch block SW1.

Figure 9: *IRQ factory setting*

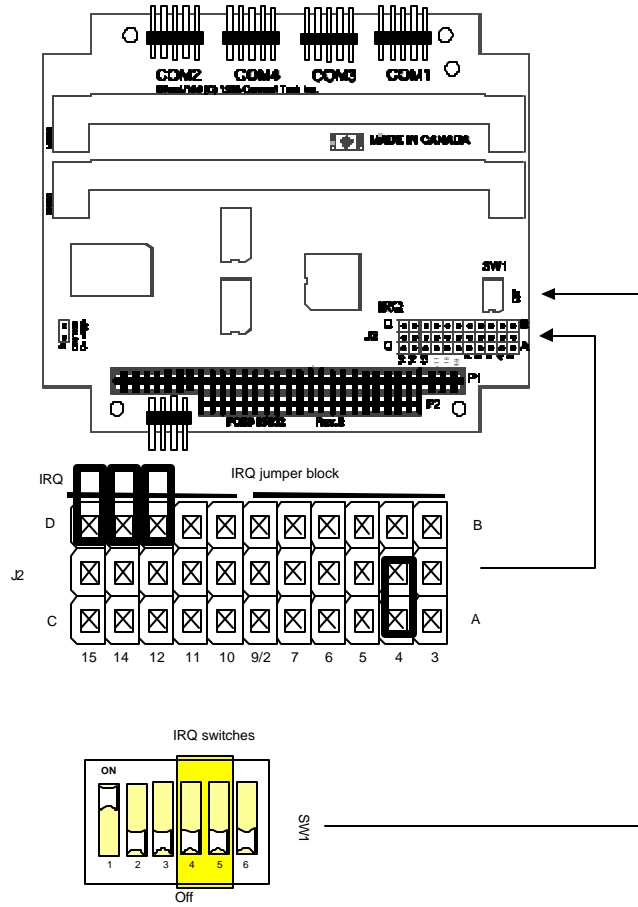

Baud Rate Setting

Jumper block J1 sets the maximum baud rate for the DFlex-4/104 adapter. Connect Tech ships the DFlex-4/104 set for a maximum baud rate of 115K baud. **Figure 10** shows the location and factory setting of jumper block J1.

Figure 10: Baud rate factory setting (J1)

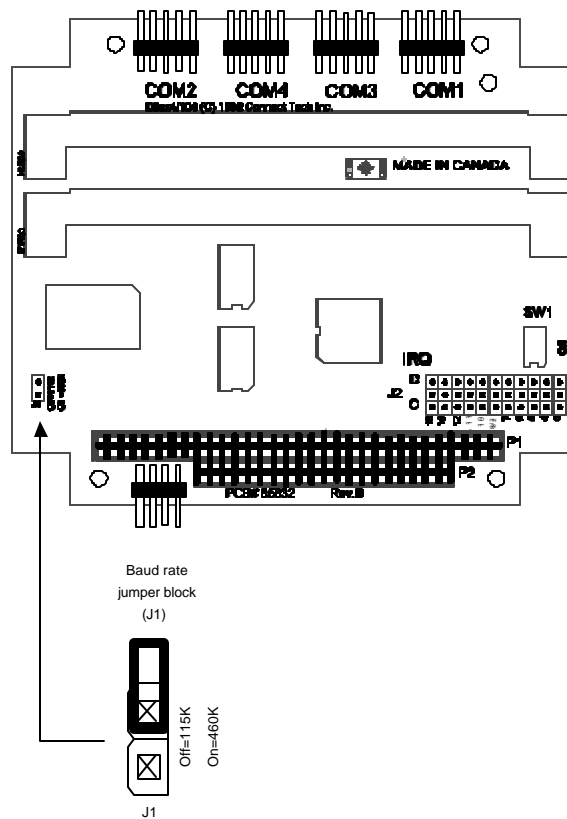

Appendix D: SLIM Insertion/Removal

SLIM insertion

Figure 11 outlines the correct procedure for removing RS-232, RS-485/422, RS-423 and 20mA current loop Serial Line Interface Modules (SLIM).

Figure 11: *SLIM insertion*

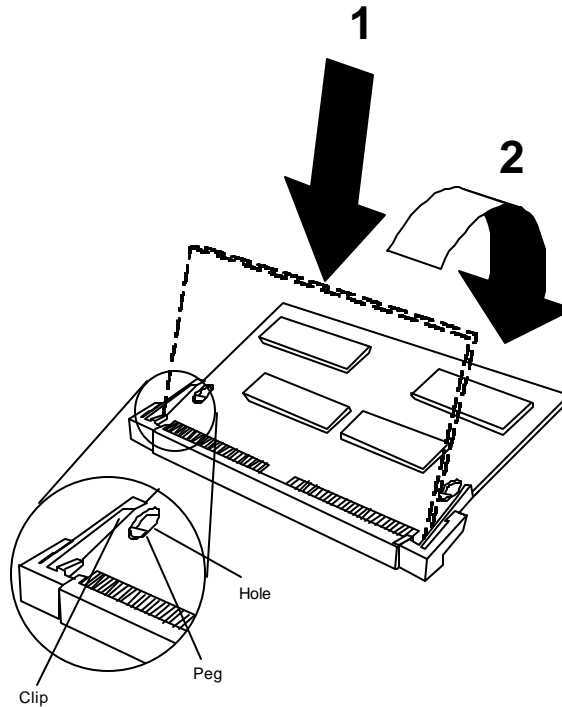

1. Place the SLIM into the socket almost vertically (about 75-degree angle), making sure that it is properly oriented and fully inserted into the socket.
2. Press downward and sideways on the SLIM until it latches into the socket. **Do NOT force the SLIM**, the installation process requires a small force and should be very smooth and easy. If you encounter resistance then re-check the orientation and insertion depth.

SLIM removal

Figure 12 outlines the correct procedure for removing a RS-232, RS-423, RS-485/422, RS-423 and 20mA current loop Serial Line Interface Module (SLIM).

Figure 12: *SLIM removal*

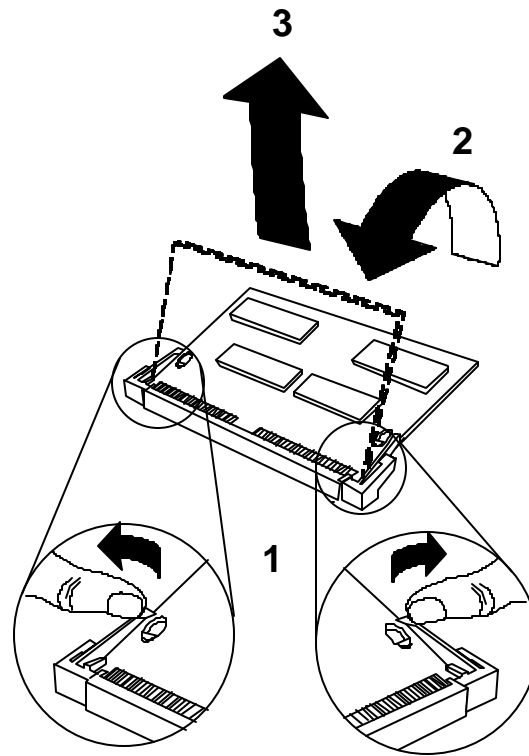

1. Using both hands, place your thumbs on the clips that hold the SLIM into the socket, and place your index fingers on the edge of the SLIM.
2. Push outwards (with your thumbs) on the clips until the SLIM is released from the clips. Your index fingers can then raise the SLIM past the clips. The SLIM is then free to be removed from the DFlex-4/104 board. The force required to open the clips is small and the SLIM naturally springs upwards as soon as the clips are open wide enough. If removal is difficult, then you are probably trying to raise the SLIM before the clips are open.

Appendix E: RS-232 SLIM Option

You may order the DFlex-4/104 adapter with RS-232 and RS-232/Fast Serial Line Interfaces Modules. The RS-232 and RS-232/Fast SLIMs offer the following features:

- n The RS-232 electrical interface, an industry standard that offers connection to a wide range of peripheral devices.
- n Each SLIM controls two ports.
- n SLIMS are field upgradeable, providing you with more flexibility for your application.

WARNING

You must insert Serial Line Interface Modules into all of the SLIM sockets to attain the communications functionality of your DFlex-4/104 adapter.

Please refer to **Figure 13** for a partial schematic of the RS-232 or RS-232/Fast SLIM

Figure 13: RS-232; RS-232/Fast SLIM: partial schematic

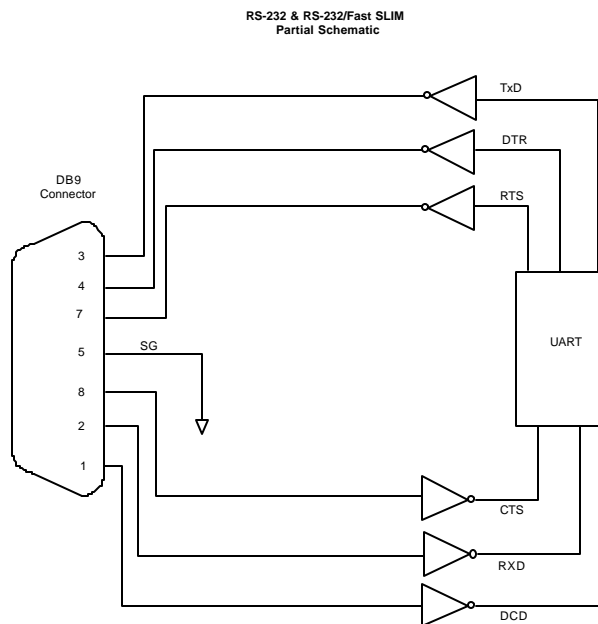

Note: The RS-232 and RS-232/Fast Serial Line Interface Module controls two ports, and therefore the schematic shows only a portion of the circuit.

RS-232/Fast SLIM

The standard RS-232 SLIM is not fully functional with a DFlex-4/104 adapter with J1 set for a maximum baud rate of 460K baud. Only the RS-232/Fast Serial Line Interface Module (SLIM) is fully functional with the DFlex-4/104 set for a maximum baud rate of 460k baud.

Installation

The DFlex-4/104 adapter has two SLIM sockets that accept Serial Line Interface Modules. SLIM 1 socket interfaces ports 1 and 2. SLIM 2 socket interfaces ports 3 and 4. Please refer to **Chapter 2: Hardware Installation** for the location of the SLIM sockets and to **Appendix D: SLIM Insertion/Removal** for the proper procedures to installing and removing SLIMs.



Your DFlex adapter and Serial Line Interface Module (SLIM) are very sensitive to static electricity. Make sure that before you remove them from the anti-static shipping bag, you wear an anti-static wristband. When you remove them from the anti-static bag, handle them only by the edges and place them on the anti-static bag or an anti-static mat.

Please refer to **Table 8** for the pinouts for the SLIM sockets found on the DFlex-4/104 adapter.

Table 8: *SLIM pinouts*

SLIM Pin No.	TIL Signal	RS-232 Signal	RS-485 Signal	RS-423 Signal	Current Loop Signal
1	N/C				
2		RTS 1	RTS A(-) 1	RTS (-) 1	TxD(-) 1
3		TxD 1	TxD A(-) 1	TxD (-) 1	TxD Source 1
4		CTS 1	RTS B(+) 1	RTS Ref 1	RxD(+) 1
5		RxD 1	TxD B(+) 1	TxD Ref 1	TxD(+) 1
6		N/C	CTS A(-) 1	CTS A(-) 1	RxD Return 1
7		DTR 1	RxD A(-) 1	RxD A(-) 1	TxD Return 1
8		N/C	CTS B(+) 1	CTS B(+) 1	RxD Source 1
9		DCD 1	RxD B(+) 1	RxD B(+) 1	RxD(-) 1
10		RTS 2	RTS A(-) 2	RTS (-) 2	TxD(-) 2
11		TxD 2	TxD A(-) 2	TxD (-) 2	TxD Source 2
12		CTS 2	RTS B(+) 2	RTS Ref 2	RxD(+) 2
13		RxD 2	TxD B(+) 2	TxD Ref 2	TxD(+) 2
14		N/C	CTS A(-) 2	CTS A(-) 2	RxD Return 2
15		DTR 2	RxD A(-) 2	RxD A(-) 2	TxD Return 2
16		N/C	CTS B(+) 2	CTS B(+) 2	RxD Source 2
17		DCD 2	RxD B(+) 2	RxD B(+) 2	RxD(-) 2
18	Ground				
19	+12 V				
20	-12 V				
21	+5 V				
22	DCD 2		Tied high	Tied high	Tied high
23	CTS 2				Tied high
24	RTS 2				
25	DTR 2				
26	TxD 2				
27	RxD 2				
28	RxD 1				
29	TxD 1				
30	DTR 1				
31	RTS 1				
32	CTS 1				Tied high
33	DCD 1		Tied high	Tied high	Tied high
34	TC				
35	RC				

Note: *earlier versions of the current loop SLIM have pins 22, 23, 32, and 33 tied low.*

Appendix F: RS-485/422 Options

You may order the DFlex-4/104 adapter with RS-485/422 Serial Line Interfaces Modules. The RS-485/422 electrical interface is a reliable high-speed serial link that offers superior noise immunity and multi-drop network connectivity. The RS-485/422 electrical interface is also a superset of the RS-422 electrical interface.

WARNING

You must insert Serial Line Interface Modules into all of the SLIM sockets to attain the communications functionality of your DFlex-4/104 adapter.

Installation

The DFlex-4/104 adapter has two SLIM sockets that accept Serial Line Interface Modules. SLIM 1 socket interfaces ports 1 and 2. SLIM 2 socket interfaces ports 3 and 4. Please refer to **Chapter 2: Hardware Installation** for the location of the SLIM sockets and to **Appendix D: SLIM Insertion/Removal** for the proper procedures to installing and removing SLIMs.



Your DFlex-4/104 adapter and Serial Line Interface Module (SLIM) are very sensitive to static electricity. Make sure that before you remove them from the anti-static shipping bag, you wear an anti-static wristband. When you remove them from the anti-static bag, handle them only by the edges and place them on the anti-static bag or an anti-static mat.

RS-485/422 SLIM

You can use the RS-485/422 SLIM in 2 wire and 4 wire multi-drop configurations where the RS-485 line drivers are disabled to allow other devices access to the line.

Your DFlex-4/104 adapter does not provide DIP switches to control the driver enables for the RS-485 SLIM. Instead, the DTR signal is used to gate the control. If DTR is asserted, the drivers are always enabled. If DTR is not asserted, then the driver will be enabled only when RTS is asserted. To disable the RS-485 line driver you must **not assert** DTR and RTS.

Also, the receivers on the RS-485 SLIM are biased high through fixed resistors. Please refer to **Figure 14** for a partial schematic of the RS-485/422 SLIM circuit, while **Table 9** shows the pinouts for the SLIM sockets found on the DFlex-4/104 adapter.



Your DFlex-4/104 adapter is very sensitive to static electricity. Make sure that before you remove the card from the anti-static shipping bag, you wear an anti-static wristband. When you remove the board from the anti-static bag, handle it only by the edges and place it on the anti-static bag or an anti-static mat.

Figure 14: RS-485/422 SLIM partial schematic

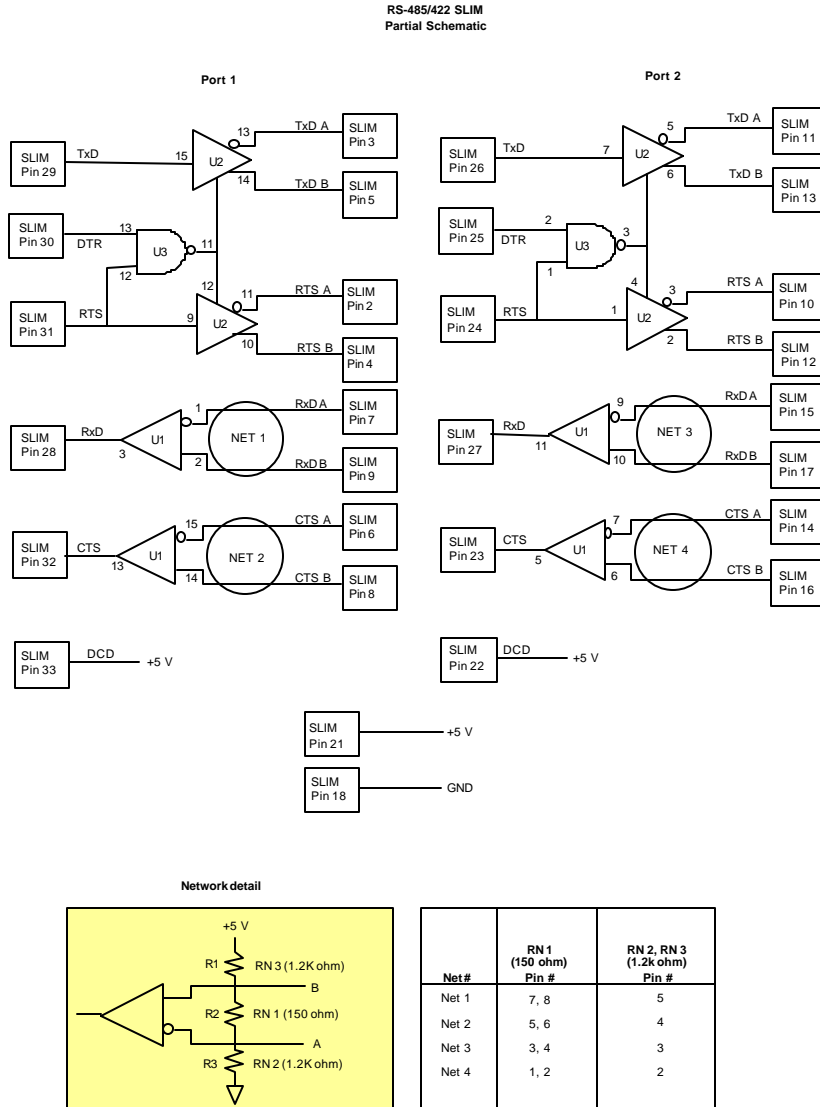

Note: As an RS-485/422 Serial Line Interface Module controls two ports, the schematic shows the circuit for two ports.

Table 9: *SLIM pinouts*

SLIM Pin No.	TIL Signal	RS-232 Signal	RS-485 Signal	RS-423 Signal	Current Loop Signal
1	N/C				
2		RTS 1	RTS A(-) 1	RTS (-) 1	TxD(-) 1
3		TxD 1	TxD A(-) 1	TxD (-) 1	TxD Source 1
4		CTS 1	RTS B(+) 1	RTS Ref 1	RxD(+) 1
5		RxD 1	TxD B(+) 1	TxD Ref 1	TxD(+) 1
6		N/C	CTS A(-) 1	CTS A(-) 1	RxD Return 1
7		DTR 1	RxD A(-) 1	RxD A(-) 1	TxD Return 1
8		N/C	CTS B(+) 1	CTS B(+) 1	RxD Source 1
9		DCD 1	RxD B(+) 1	RxD B(+) 1	RxD(-) 1
10		RTS 2	RTS A(-) 2	RTS (-) 2	TxD(-) 2
11		TxD 2	TxD A(-) 2	TxD (-) 2	TxD Source 2
12		CTS 2	RTS B(+) 2	RTS Ref 2	RxD(+) 2
13		RxD 2	TxD B(+) 2	TxD Ref 2	TxD(+) 2
14		N/C	CTS A(-) 2	CTS A(-) 2	RxD Return 2
15		DTR 2	RxD A(-) 2	RxD A(-) 2	TxD Return 2
16		N/C	CTS B(+) 2	CTS B(+) 2	RxD Source 2
17		DCD 2	RxD B(+) 2	RxD B(+) 2	RxD(-) 2
18	Ground				
19	+12 V				
20	-12 V				
21	+5 V				
22	DCD 2		Tied high	Tied high	Tied high
23	CTS 2				Tied high
24	RTS 2				
25	DTR 2				
26	TxD 2				
27	RxD 2				
28	RxD 1				
29	TxD 1				
30	DTR 1				
31	RTS 1				
32	CTS 1				Tied high
33	DCD 1		Tied high	Tied high	Tied high
34	TC				
35	RC				

Note: *earlier versions of the current loop SLIM have pins 22, 23, 32, and 33 tied low.*

RS-485/422 Cable Wiring

You can wire DFlex-4/104 adapters with the RS-485/422 option in various ways to communicate with RS-485/422 peripherals. This section will describe a few examples of RS-485/422 cabling schemes.

Figure 15 describes a 4 wire cabling scheme between a port on the DFlex-4/104 adapter to a port on the RS-485/422 peripheral.

Figure 15: RS-485/422 wiring diagram (4 wire)

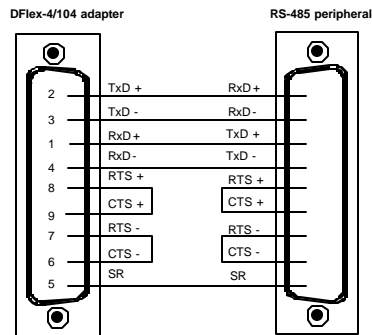
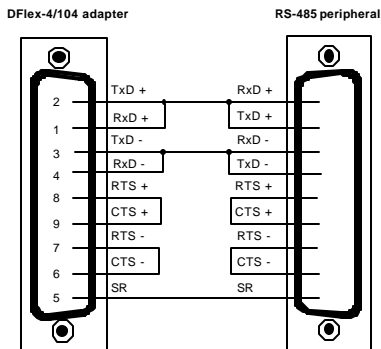

Figure 16 describes a 2 wire cabling scheme between a port on the DFlex-4/104 adapter to a port on the RS-485/422 peripheral.

Figure 16: RS-485/422 wiring diagram (2 wire)



Appendix G: RS-423 Options

You may order the DFlex-4/104 adapter with RS-423 Serial Line Interfaces Module. The RS-423 electrical interface is a reliable high-speed serial link that offers superior noise immunity.

WARNING

You must insert Serial Line Interface Modules into all of the SLIM sockets to attain the communications functionality of your DFlex-4/104 adapter.

Please refer to **Figure 17** for a partial schematic of the RS-423 SLIM circuit

Figure 17: RS-423 SLIM partial schematic

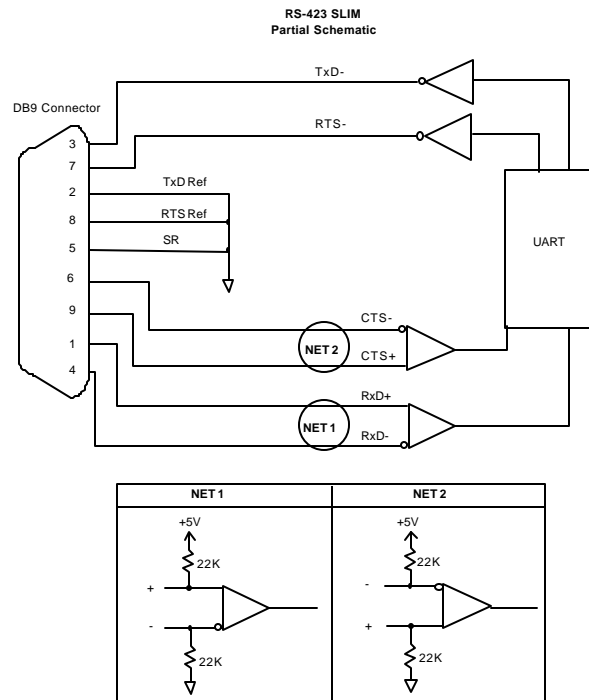

Note: Note: The RS-423 Serial Line Interface Module controls two ports, and therefore the schematic shows only a portion of the circuit.

Installation

The DFlex-4/104 adapter has two SLIM sockets that accept Serial Line Interface Modules. SLIM 1 socket interfaces ports 1 and 2. SLIM 2 socket interfaces ports 3 and 4. Please refer to **Chapter 2: Hardware Installation** for the location of the SLIM sockets and to **Appendix D: SLIM Insertion/Removal** for the proper procedures to installing and removing SLIMs.



Your DFlex-4/104 adapter and Serial Line Interface Module (SLIM) are very sensitive to static electricity. Make sure that before you remove them from the anti-static shipping bag, you wear an anti-static wrist-band. When you remove them from the anti-static bag, handle them only by the edges and place them on the anti-static bag or an anti-static mat.

Please refer to **Table 10** for the pinouts for the SLIM sockets found on the DFlex-4/104 adapter.

Table 10: *SLIM pinouts*

SLIM Pin No.	TIL Signal	RS-232 Signal	RS-485 Signal	RS-423 Signal	Current Loop Signal
1	N/C				
2		RTS 1	RTS A(-) 1	RTS (-) 1	TxD(-) 1
3		TxD 1	TxD A(-) 1	TxD (-) 1	TxD Source 1
4		CTS 1	RTS B(+) 1	RTS Ref 1	RxD(+) 1
5		RxD 1	TxD B(+) 1	TxD Ref 1	TxD(+) 1
6		N/C	CTS A(-) 1	CTS A(-) 1	RxD Return 1
7		DTR 1	RxD A(-) 1	RxD A(-) 1	TxD Return 1
8		N/C	CTS B(+) 1	CTS B(+) 1	RxD Source 1
9		DCD 1	RxD B(+) 1	RxD B(+) 1	RxD(-) 1
10		RTS 2	RTS A(-) 2	RTS (-) 2	TxD(-) 2
11		TxD 2	TxD A(-) 2	TxD (-) 2	TxD Source 2
12		CTS 2	RTS B(+) 2	RTS Ref 2	RxD(+) 2
13		RxD 2	TxD B(+) 2	TxD Ref 2	TxD(+) 2
14		N/C	CTS A(-) 2	CTS A(-) 2	RxD Return 2
15		DTR 2	RxD A(-) 2	RxD A(-) 2	TxD Return 2
16		N/C	CTS B(+) 2	CTS B(+) 2	RxD Source 2
17		DCD 2	RxD B(+) 2	RxD B(+) 2	RxD(-) 2
18	Ground				
19	+12 V				
20	-12 V				
21	+5 V				
22	DCD 2		Tied high	Tied high	Tied high
23	CTS 2				Tied high
24	RTS 2				
25	DTR 2				
26	TxD 2				
27	RxD 2				
28	RxD 1				
29	TxD 1				
30	DTR 1				
31	RTS 1				
32	CTS 1				Tied high
33	DCD 1		Tied high	Tied high	Tied high
34	TC				
35	RC				

Note: *earlier versions of the current loop SLIM have pins 22, 23, 32, and 33 tied low.*

RS-423 Cable Wiring

You can wire DFflex-4/104 adapter with the RS-423 option in various ways to communicate with RS-423 peripherals. This section will describe a few examples of RS-423 cabling schemes.

Figure 18 describes a 4 wire cabling scheme between a port on the DFflex-4/104 adapter to a port on the RS-423 peripheral.

Figure 18: RS-423 wiring diagram (4 wire)

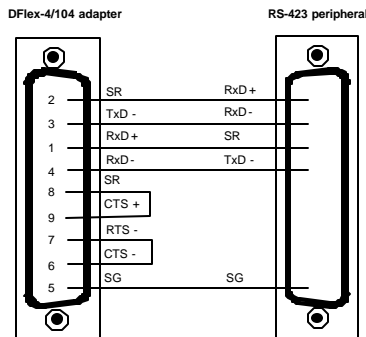
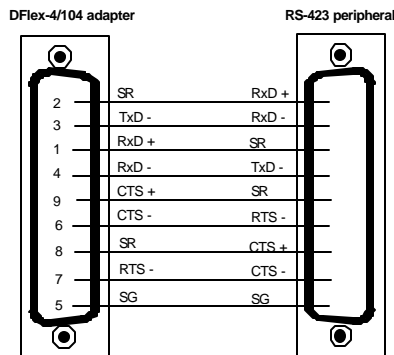

Figure 19 describes an all wire cabling scheme between a port on the DFflex-4/104 adapter to a port on the RS-423 peripheral.

Figure 19: RS-423 wiring diagram (all wire)



Appendix H: 20mA Current Loop Option

You may order DFlex-4/104 adapter with 20mA current loop Serial Line Interface Modules. The 20mA current loop electrical interface provides a reliable high speed serial link over long distances that offers superior noise immunity and multi-drop network connectivity.

WARNING

You must insert Serial Line Interface Modules into all of the SLIM sockets to attain the communications functionality of your DFlex-4/104 adapter.

Installation

The DFlex-4/104 adapter has two SLIM sockets that accept Serial Line Interface Modules. SLIM 1 socket interfaces ports 1 and 2. SLIM 2 socket interfaces ports 3 and 4. Please refer to **Chapter 2: Hardware Installation** for the location of the SLIM sockets and to **Appendix D: SLIM Insertion/Removal** for the proper procedures to installing and removing SLIMs.



Your DFlex-4/104 adapter and Serial Line Interface Module (SLIM) are very sensitive to static electricity. Make sure that before you remove them from the anti-static shipping bag, you wear an anti-static wrist-band. When you remove them from the anti-static bag, handle them only by the edges and place them on the anti-static bag or an anti-static mat.

20mA Current Loop SLIM

The 20mA current loop module provides optically isolated 20mA active or passive current loop interfaces for two ports. For each port there is an isolated receiver, an optically isolated transmitter and two 20mA current sources. See **Figure 20** for the schematic of the 20mA current loop module.

Note: The current source uses a compliance voltage of 24 volts, and the transmitter will withstand a 27 volt drop. Please refer to the Hewlett Packard Optoelectronics Manual/Catalogue for a complete description of HPCL 4100 and HPCL 4200 specifications.

Figure 20: 20mA Current Loop SLIM schematic

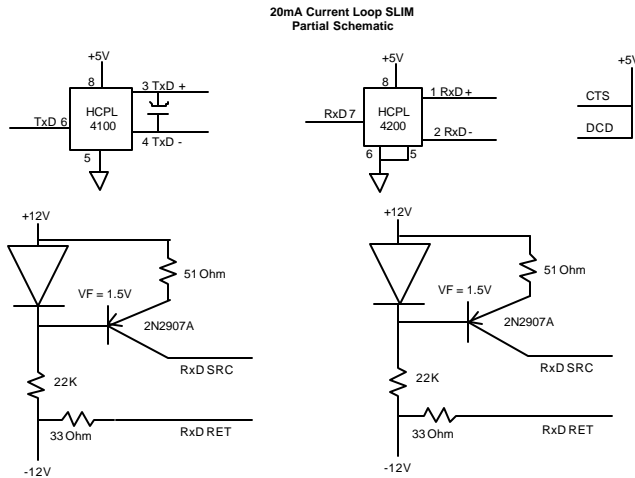

Where:

SLIM Pin No.	Current Loop Signal	SLIM Pin No.	Current Loop Signal
2	TxD(-) 1	14	RxD Return 2
3	TxD Source 1	15	TxD Return 2
4	RxD(+) 1	16	RxD Source 2
5	TxD(+) 1	17	RxD(-) 2
6	RxD Return 1	18	Gnd
7	TxD Return 1	19	+12 V
8	RxD Source 1	20	-12 V
9	RxD(-) 1	21	+5 V
10	TxD(-) 2	22	DCD 2 (+5 V)
11	TxD Source 2	23	CTS 2 (+5 V)
12	RxD(+) 2	32	CTS 1 (+5 V)
13	TxD(+) 2	33	DCD 1 (+5 V)

To implement a passive interface, wire the transmitter and the receiver, while leaving the current sources unconnected. An external current source is required to implement a passive interface.

To implement an active interface, connect a 20mA current source in series with the transmitter and another 20mA current source in series with the receiver. Please refer to **Figure 21** for a 20mA current loop cable wiring configuration between one port of a DFlex-4/104 adapter and another port of a DFlex-4/104 adapter. This example shows wiring for both active and passive modes.

When you use a current loop SLIM as a current source in the loop and the 20mA is flowing, the corresponding LED on the Serial Line Interface Module will light. If the loop is open or the current loop SLIM is not used as a current source the LED will be off.

WARNING

When using the current source in a loop with low resistance, the transistor will run hot. This can be avoided by increasing the loop resistance. The calculation for Maximum Loop Resistance(R_L) is:

$$\text{Max } R_L = \frac{22 - (S \times V_D)}{0.020}$$

Note:

1. S = the number of stations in the loop (TX's and RX's)
2. V_D = the voltage drop for the HP opto couplers on the SLIM. $V_D = 2.3$ V for the HPCL 4100 and HPCL 4200. When you use other manufacturers' equipment in the loop the value of V_D may differ.

Please refer to **Table 11** for the pinouts for the SLIM sockets found on the DFlex-4/104 adapter.

Table 11: SLIM pinouts

SLIM Pin No.	TIL Signal	RS-232 Signal	RS-485 Signal	RS-423 Signal	Current Loop Signal
1	N/C				
2		RTS 1	RTS A(-) 1	RTS (-) 1	TxD(-) 1
3		TxD 1	TxD A(-) 1	TxD (-) 1	TxD Source 1
4		CTS 1	RTS B(+) 1	RTS Ref 1	RxD(+) 1
5		RxD 1	TxD B(+) 1	TxD Ref 1	TxD(+) 1
6		N/C	CTS A(-) 1	CTS A(-) 1	RxD Return 1
7		DTR 1	RxD A(-) 1	RxD A(-) 1	TxD Return 1
8		N/C	CTS B(+) 1	CTS B(+) 1	RxD Source 1
9		DCD 1	RxD B(+) 1	RxD B(+) 1	RxD(-) 1
10		RTS 2	RTS A(-) 2	RTS (-) 2	TxD(-) 2
11		TxD 2	TxD A(-) 2	TxD (-) 2	TxD Source 2
12		CTS 2	RTS B(+) 2	RTS Ref 2	RxD(+) 2
13		RxD 2	TxD B(+) 2	TxD Ref 2	TxD(+) 2
14		N/C	CTS A(-) 2	CTS A(-) 2	RxD Return 2
15		DTR 2	RxD A(-) 2	RxD A(-) 2	TxD Return 2
16		N/C	CTS B(+) 2	CTS B(+) 2	RxD Source 2
17		DCD 2	RxD B(+) 2	RxD B(+) 2	RxD(-) 2
18	Ground				
19	+12 V				
20	-12 V				
21	+5 V				
22	DCD 2		Tied high	Tied high	Tied high
23	CTS 2				Tied high
24	RTS 2				
25	DTR 2				
26	TxD 2				
27	RxD 2				
28	RxD 1				
29	TxD 1				
30	DTR 1				
31	RTS 1				
32	CTS 1				Tied high
33	DCD 1		Tied high	Tied high	Tied high
34	TC				
35	RC				

Note: earlier versions of the current loop SLIM have pins 22, 23, 32, and 33 tied low.

Current Loop Cable Wiring

You can wire DFlex-4/104 adapters with the 20mA Current Loop option in various ways to communicate with 20mA Current Loop peripherals. This section will describe a few examples of current loop cabling schemes.

Figure 21 describes a 4 wire cabling scheme between a port on the DFlex-4/104 adapter to another port on the DFlex-4/104 adapter.

Figure 21: *Current Loop wiring diagram (4 wire)*

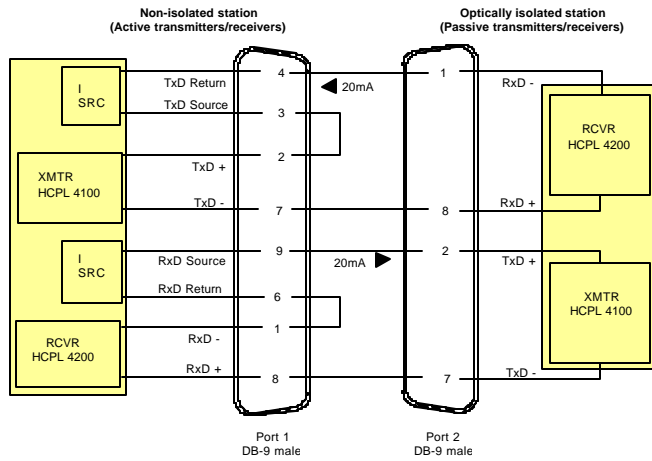

Note:

The example above illustrates a 20mA current loop cable wiring configuration between one port of an DFlex-4/104 adapter and another port of an DFlex-4/104 adapter. This example shows wiring for both active and passive modes