

ACP-5152

15.6" Fanless Multi-Touch Window Computer With Onboard Intel® Dual Core Atom™ D510 Processor

04

Infotainment Multi-Touch Panel Solutions

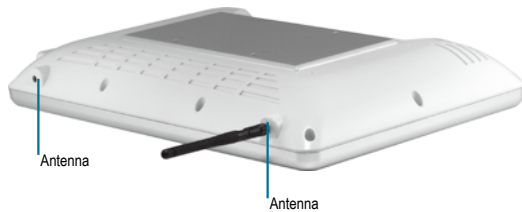
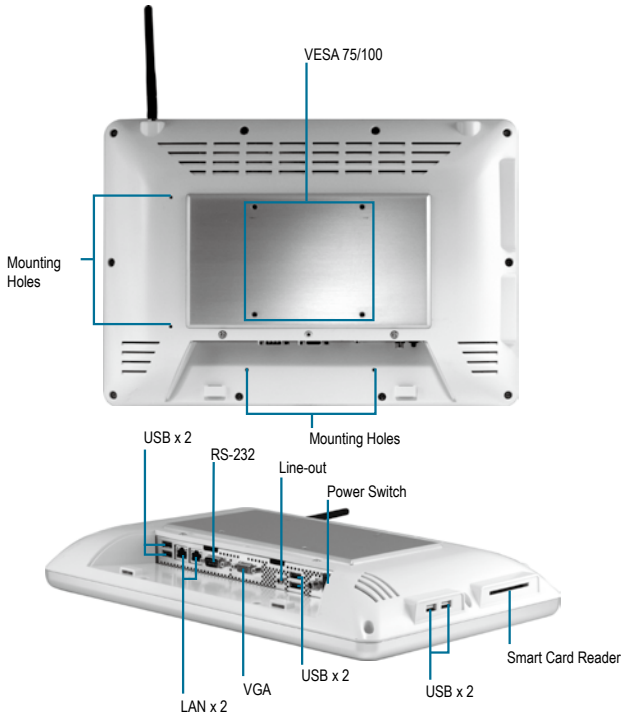
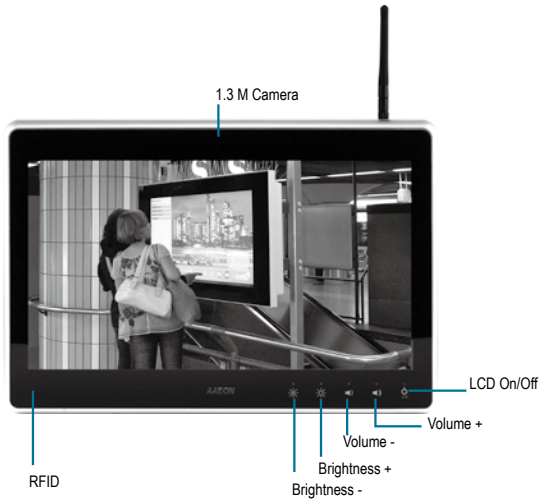

Features

- 15.6" WXGA (1366 x 768) Fanless TFT LCD Display
- Superior Onboard Intel® Dual Core Atom™ D510 Processor
- Easy-To-Clean: Multi-Touch Window Design (Two-Point)
- IPX1 100% Water-Proof
- Anti-Scratch Surface (7H Hardness)
- Smart Card Reader/ RF ID/ MSR/ Skype Phone/ Camera Support



Specifications

System	
Processor	Onboard Intel® Dual Core Atom™ D510 1.66 GHz
Memory	DDR2 SODIMM x1, up to 2GB
LCD/CRT Controller	Integrated in Processor
Ethernet	10/100/1000Base-TX, RJ-45 x 2
I/O Port	RS-232 x 1, USB2.0 x 6 (2 on side; 4 on rear), Line-out x 1, VGA x 1,
Storage Disk Drive	2.5" SATA Hard Disk Drive/ CompactFlash™ Slot (Internal)
Expansion Slot	Mini card x 2
OS Support	Windows® XP (T/S: Single point), Linux Fedora (T/S: Single point), Windows® 7 (T/S: Multi-point)
Mechanical	
Construction	IP-65/ NEMA4 for plastic front bezel, IPX1 for plastic chassis
Mounting	VESA 75/100
Dimension	15.5" x 10.7" x 2.44" (394mm x 272mm x 62mm)
Carton Dimension	—
Gross Weight	—
Net Weight	—
Environmental	
Operating Temperature	32°F ~ 113°F (0°C ~ 45°C)(Ambient with Airflow)
Storage Temperature	-4°F ~ 140°F (-20°C ~ 60°C)
Storage Humidity	10%~95% @ 40°C; non-condensing
Vibration	1 g rms/ 5~500Hz/ Random operation (HDD)
Shock	15 G peak acceleration (11 msec. Duration)
EMC	CE/FCC Class A
Power Supply	
DC input 70W	DC 12V, with AC power adapter with lock
LCD	
Display type	15.6" TFT-LCD, CCFL
Max Resolution	1366 x 768
Max. Colors	16.7M colors (6/8-bit for R,G,B)
Luminance	300 cd/m²
Viewing Angle	170°(H), 160°(V)
Back Light	CCFL
Back Light MTBF (hours)	50,000
Touchscreen	
Type	Projected Capacitive Multi-Touch (Windows® 7)
Light Transmission	90%
Lifetime (times)	—

ACP-5152

Dimension

Unit: mm

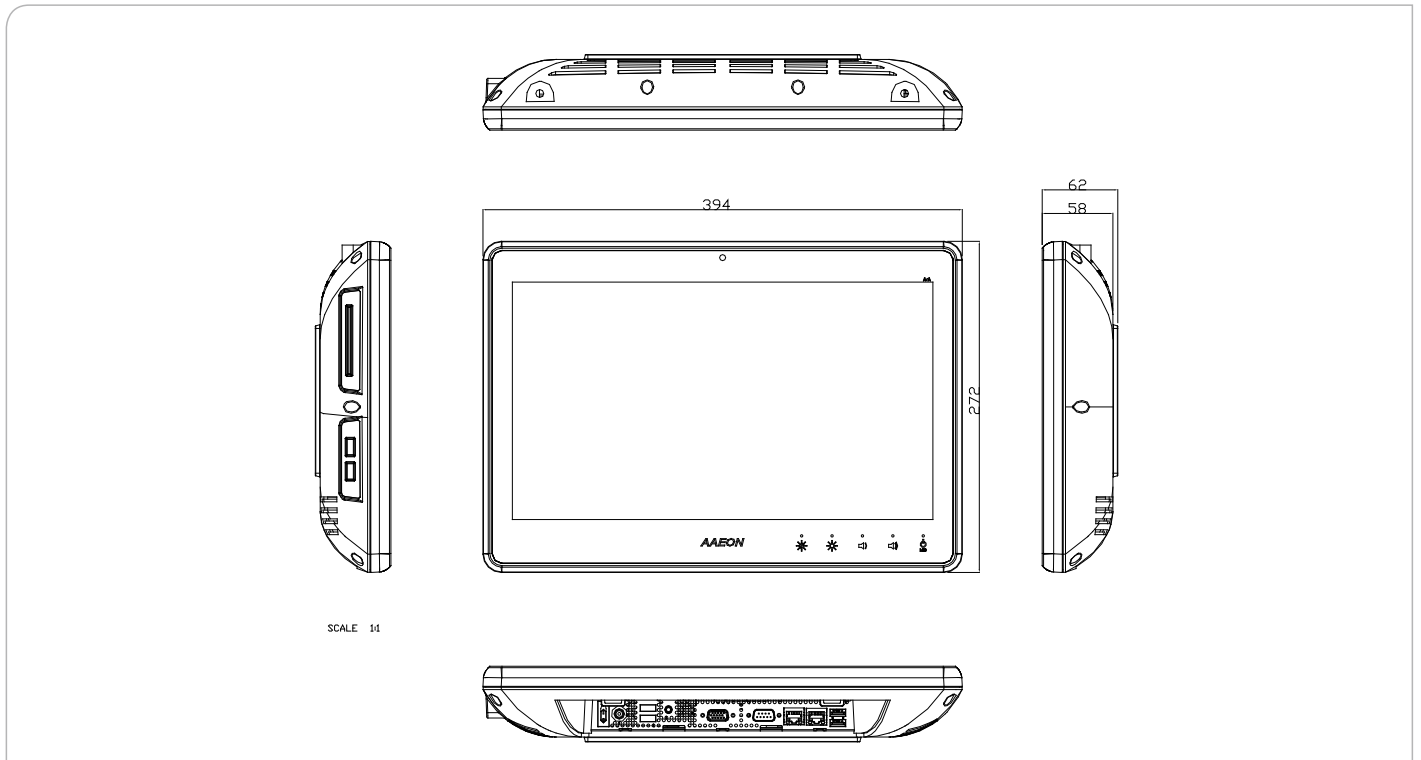

Ordering Information

• TF-ACP-5152-A1-1010

15.6" Fanless Multi-Touch Window Panel Computer with Onboard Intel® Dual Core Atom™ D510, DDR2 SODIMM 1GB

Optional Accessories

- Desktop Stand
- Wallmount Kit
- 1702031802
Power Cord (US Type)
- 1702031803
Power Cord (European Type)
- 170203180E
Power Cord (Japanese Type)
- AC/DC Power Adapter
- Smart Card Reader
- Camera (1.3M Pixel)
- RF ID (13.56 Hz)
- Skype Phone + Mounting Kit
- MSR + Mounting Kit
- Scanner (1D) + Mounting Kit
- WiFi Module (Mini Card)
- WiFi Antenna