

AEC-6820

Fanless Embedded Control PC
Transmeta 733MHz/1GHz CPU
With 2 PCMCIA slots, Ethernet,
2 COMs, Audio, CompactFlash™

AEC-6820 Manual 1st Ed.
Dec. 2004

Copyright Notice

This document is copyrighted, 2004. All rights are reserved. The original manufacturer reserves the right to make improvements to the products described in this manual at any time without notice.

No part of this manual may be reproduced, copied, translated, or transmitted in any form or by any means without the prior written permission of the original manufacturer. Information provided in this manual is intended to be accurate and reliable. However, the original manufacturer assumes no responsibility for its use, or for any infringements upon the rights of third parties that may result from its use.

The material in this document is for product information only and is subject to change without notice. While reasonable efforts have been made in the preparation of this document to assure its accuracy, AAEON assumes no liabilities resulting from errors or omissions in this document, or from the use of the information contained herein.

AAEON reserves the right to make changes in the product design without notice to its users.

Acknowledgments

All other products' name or trademarks are properties of their respective owners.

- Award is a trademark of Award Software International, Inc.
- CompactFlash™ is a trademark of the Compact Flash Association.
- VIA Eden™ is a trademark of VIA Technology Inc.
- Microsoft Windows® is a registered trademark of Microsoft Corp.
- PC/AT, PS/2, and VGA are trademarks of International Business Machines Corporation.

Packing List

Before you begin operating your PC, please make sure that the following materials have been shipped:

- 1 AEC-6820 Embedded Control PC
- 1 Keyboard & mouse cable
- 1 Phoenix Power Connector
- 2 Wall Mount Bracket
- 1 Audio Cable
- 1 Screw Package
- 1 CD-ROM for manual (in PDF format) and drivers

If any of these items should be missing or damaged, please contact your distributor or sales representative immediately.

Safety & Warranty

1. Read these safety instructions carefully.
2. Keep this user's manual for later reference.
3. Disconnect this equipment from any AC outlet before cleaning. Do not use liquid or spray detergents for cleaning. Use a damp cloth.
4. For pluggable equipment, the power outlet must be installed near the equipment and must be easily accessible.
5. Keep this equipment away from humidity.
6. Put this equipment on a reliable surface during installation. Dropping it or letting it fall could cause damage.
7. The openings on the enclosure are for air convection. Protect the equipment from overheating. **DO NOT COVER THE OPENINGS.**
8. Make sure the voltage of the power source is correct before connecting the equipment to the power outlet.
9. Position the power cord so that people cannot step on it. Do not place anything over the power cord.
10. All cautions and warnings on the equipment should be noted.
11. If the equipment is not used for a long time, disconnect it from the power source to avoid damage by transient over-voltage.
12. Never pour any liquid into an opening. This could cause fire or electrical shock.
13. Never open the equipment. For safety reasons, only qualified service personnel should open the equipment.
14. If any of the following situations arises, get the equipment checked

by service personnel:

- a. The power cord or plug is damaged.
 - b. Liquid has penetrated into the equipment.
 - c. The equipment has been exposed to moisture.
 - d. The equipment does not work well, or you cannot get it to work according to the users manual.
 - e. The equipment has been dropped and damaged.
 - f. The equipment has obvious signs of breakage.
15. DO NOT LEAVE THIS EQUIPMENT IN AN ENVIRONMENT WHERE THE STORAGE TEMPERATURE IS BELOW -20°C (-4°F) OR ABOVE 60°C (140°F). IT MAY DAMAGE THE EQUIPMENT.

FCC Safety

Warning!



This device complies with Part 15 FCC Rules.

Operation is subject to the following two conditions:

- (1) this device may not cause harmful interference,
- and (2) this device must accept any interference received including interference that may cause undesired operation.

Caution:

It may cause danger of explosion if battery is incorrectly replaced. Replace only with the same or equivalent type recommended by the manufacturer. Dispose of used batteries according to the manufacturer's instructions.

Contents

Copyright Notice	2
Acknowledgments	3
Packing List	4
Safety & Warranty	5
FCC Safety	6

General Information.....9

Introduction	10
Features.....	11
Specifications	12

Hardware Installation.....15

Dimension	16
HDD Module Installation.....	17
SDRAM Installation	22
COM2 RS-232/422/485 Setting.....	24
Power Linkage Installation.....	25
Wall-mount Installation.....	27
Din Rail Installation	28
COM2 RS-232/422/485 Serial Port Connector	29
COM1 RS-232 Serial Port Connector	29

Award BIOS Setup.....30

System test and initialization	31
--------------------------------------	----

Award BIOS setup.....	32
Standard CMOS Features.....	34
Advanced BIOS Features.....	38
Integrated peripherals	42
Power Management Setup.....	48
PnP/PCI configurations	51
PC Health Status	53
Load Fail-safe Defaults.....	53
Load Optimized Defaults	54
Set Supervisor/User Password.....	54
Save & Exit setup.....	56
Exit without saving.....	56
Driver Installation.....	57
Installation 1	58
Installation 2	59
Installation 3	60
Programming the Watchdog	
Timer.....	61
Programming the Watchdog timer.....	62

Chapter

1

General Information

Introduction

The AEC-6820 Embedded Control PC continues the design concept with AEC-6810 but focus on intelligent transportation system market. The highest-performance model equipped with processor up to 1GHz is superior to all “Fan-Less” products in the current market. The tough vibration test has been certificated up to 6 g rms. With the anti-vibration HDD device, it can be applied in the tough environment with high vibration frequency.

Two PCMCIA slots provide excellent expansibility for mobile devices, the ideal interface focus on wireless application which can communicate with control center for vehicle data record and transportation system. Supporting DC power input 9~30V suits for most of vehicles and factory equipments. Low power consumption system operates without fan in temperatures ranging from -15° to 70°C. Besides, it passed the critical EMC certification - CE / FCC class B.

The compact size model offers the end user more flexibilities and alternatives for system integration and arrangement. The system supports various operation systems such as Windows CE.NET 4.2, Windows XP Embedded and normal Windows family.

Besides ITS market, the AEC-6820 can fulfill applications in the following markets: environment and industrial facility, measurement and relevant IPC boundaries and take advantages of AEC-6820 to push ahead the particular market.

Features

- Fanless Design with Transmeta 733MHz/1GHz processor
- 2 PCMCIA slots for expansion
- WinCE.net / CFD / Optional HDD kit
- Ethernet / 2 COM / 4 USB / Audio
- Operating Temperature: -15~70 degree C
- Anti-vibration up to 6 g rms / Anti-shock up to 100g
- CE / FCC class B certified

Specifications

System

- CPU: Transmeta TM5800 733MHz/1GHz CPU
- Memory: Onboard 64MB SDRAM, SDRAM SODIMM x 1, Max. 512MB
- Expansion: PCMCIA x 2
- VGA: D-sub 15 VGA Connector
- Keyboard/Mouse: PS/2 Keyboard & Mouse
- Ethernet: 10/100Base-T Ethernet RJ-45 connector x 1
- SSD: Type II CompactFlash™ slot
- Hard Disk Storage: Optional 2.5" Slim HDD Module
- Serial Port: 1 x RS-232, 1 x RS-232/422/485
- Audio: Mic In / Line In / Line Out, by extension cable
- USB: 4 USB 1.1 Ports
- Parallel Port: 1 Parallel Port
- Watchdog Timer: Generate a time-out system reset
- Power Supply: DC Input: $9V_{DC} \sim 30V_{DC}$
AC Input: External Power Adapter (Optional)
- System Control: Power on / off switch x 1
Reset button x 1

- Indicator: Power LED x 1
HDD active LED x 1

Mechanical and Environmental

- Construction: Aluminum Alloy chassis
- Color: Dark Blue
- Mounting: Wall-mount (Default), Din Rail
- Dimension: 8.35" (W) x 2.53" (H) x 4.21" (D)
212.15mm x 64.2mm x 107mm
- Net Weight: 4.75lb (2.16kg)
- Gross Weight: 8.36lb (3.8kg)
- Operation Temperature: 5°F ~ 158°F (-15°C ~ 70°C)
- Operation Humidity: 5~95%@40C, non-condensing
- Vibration: 6 g rms / 5~500Hz / random
operation (Without HDD Module)
1 g / 5~500Hz / random
operation (With HDD Module)
- Shock: 100g peak acceleration (11 msec.
duration)
- EMC: CE/FCC class B

Front Side

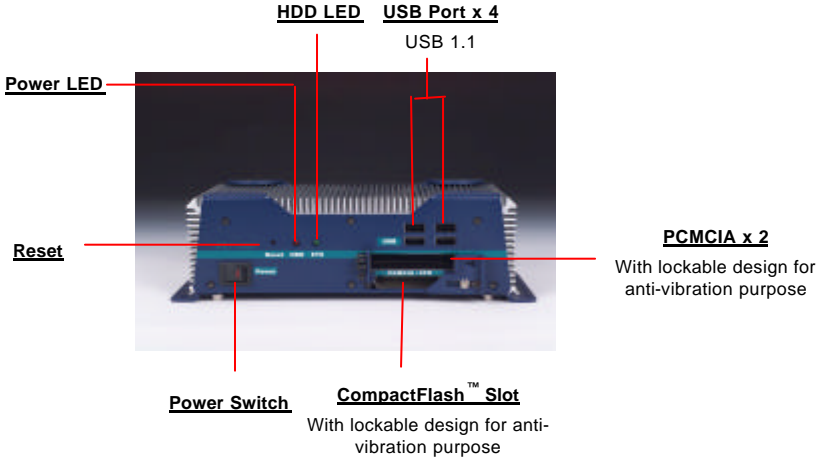

Rear Side

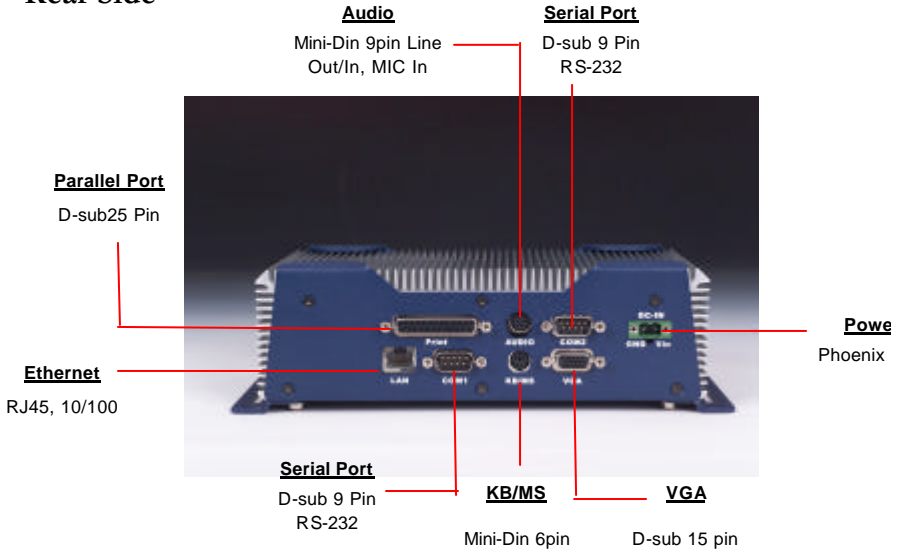

Chapter

2

**Hardware
Installation**

Dimension

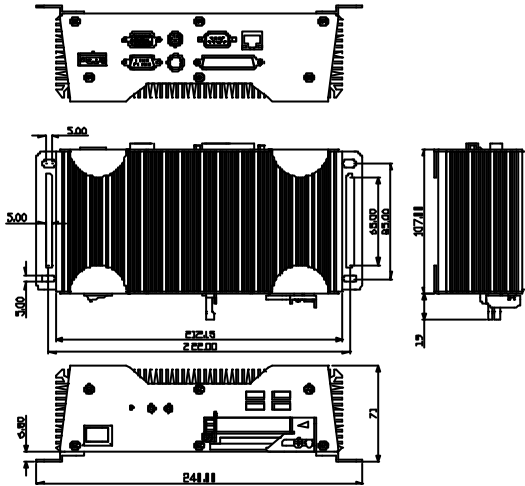

HDD Module Installation

Cable Insertion

Step 1: Open the HDD cover by loosening the screws on the bottom of the chassis.

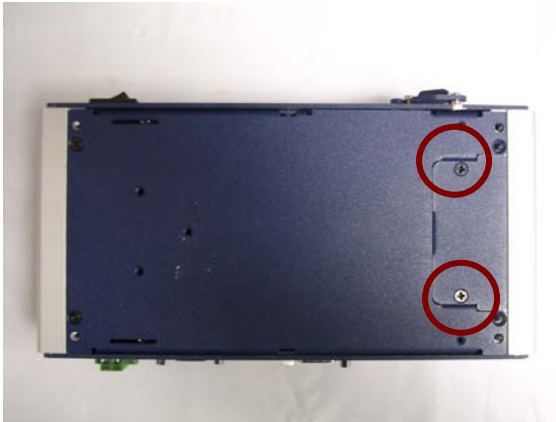

Step 2: Insert the Cable to the bottom of the chassis as the illustration below.

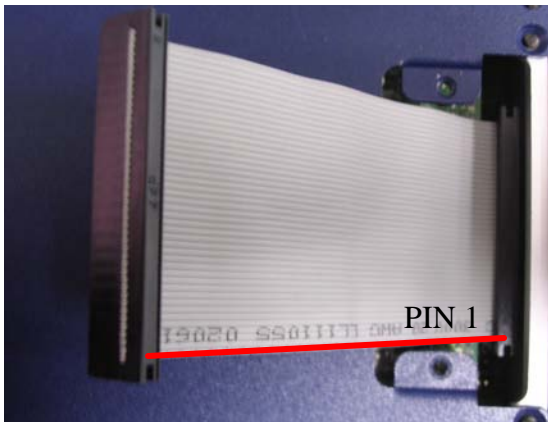
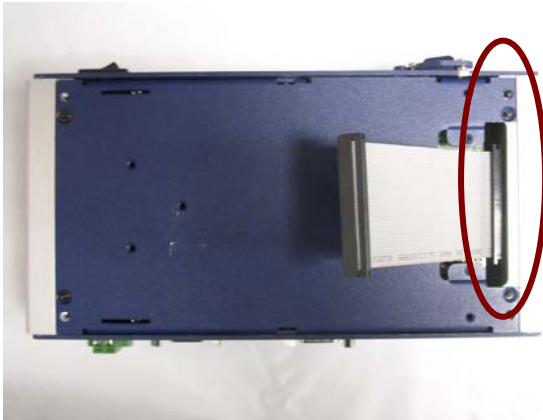

HDD Kit Combination

Get the HDD and bracket ready.

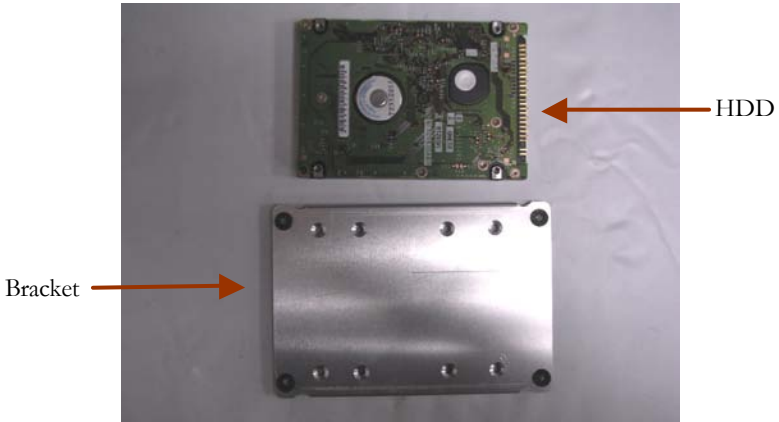

Step 1: Stack the HDD and bracket. Fasten HDD and bracket with the screws.

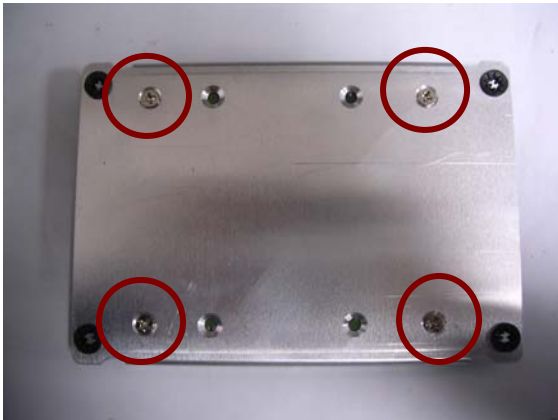

Step 2: Fasten the HDD module into the HDD kit house.



Step 3: Insert the other side of the cable to the HDD module.



Step 3: Combine the HDD kit house with the chassis and push as the illustration shown below.

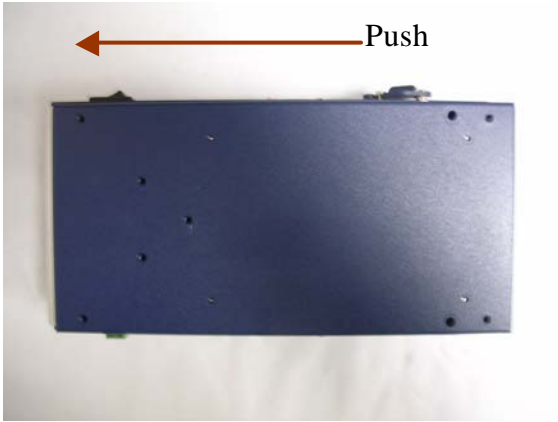

Step 4: Lock with the screws.

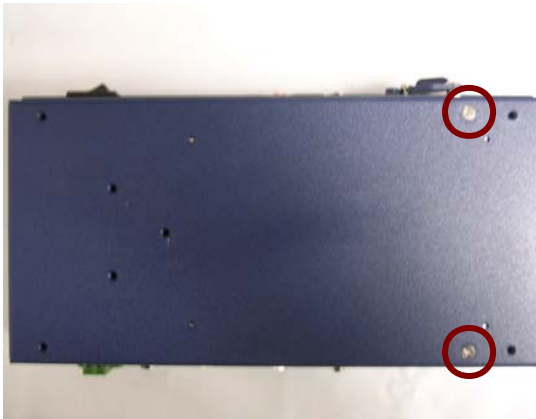

SDRAM Installation

Step 1: Screw the lid off the chassis.



Step 2: Remove the lid and insert the SDRAM SODIMM module into the slot.

SDRAM
SODIMM
module

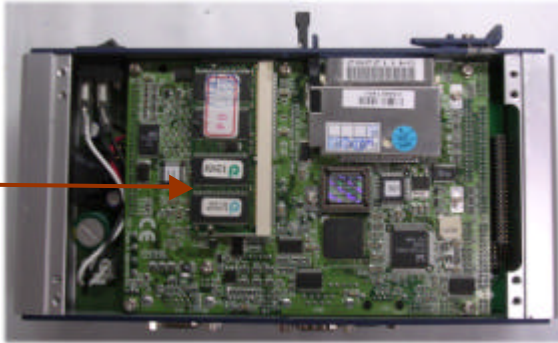

COM2 RS-232/422/485 Setting

RS-232/422/485 Selection (JP2 & JP3)

The following table provides the user to set up COM2 port.

JP2	Function
1-2, 4-5, 7-8, 10-11	RS-232 (Default)
2-3, 5-6, 8-9, 11-12	RS-422
2-3, 5-6, 8-9, 11-12	RS-485

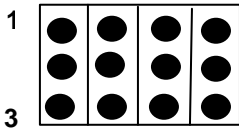

10 JP2

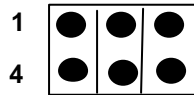

3 JP3

JP3	Function
1-2	RS-232 (Default)
3-4	RS-422
5-6	RS-485

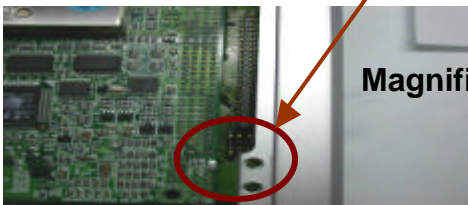

Power Linkage Installation

Step 1: Get the cable and connector ready



Step2: Fix the connector to the cable with the screws.



Step3: Insert the power cable in.



Step 4: Screw the power cable into the chassis.



Notice:

*Please make sure that pin assignment of **Power and Ground** on the accurate location.*

Wall-mount Installation

Fasten the brackets with the screws.

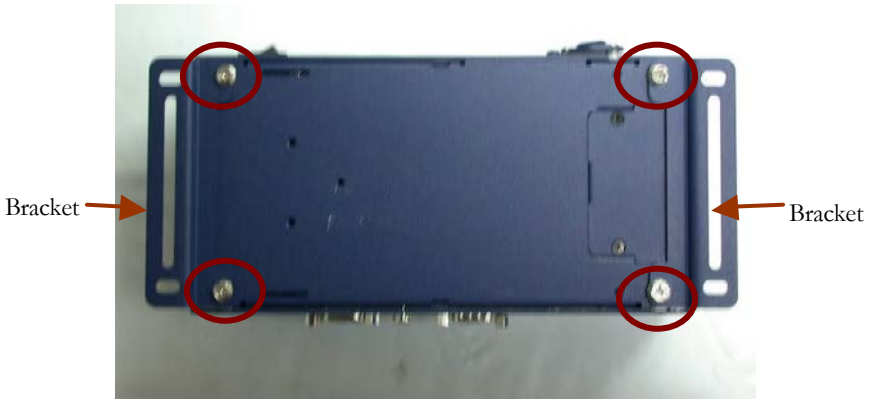

Din Rail Installation

Step 1: Fix the Din Rail kit with the screws on the chassis as the illustration shown.



Step 2: Press the Din Rail on the Din Rail kit to fix it.

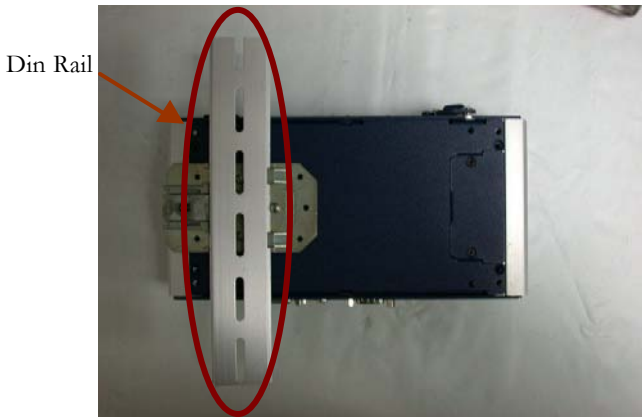

COM2 RS-232/422/485 Serial Port Connector

Different devices implement the RS-232/422/485 standard in different ways. If you are having problems with a serial device, be sure to check the pin assignments below for the connector.

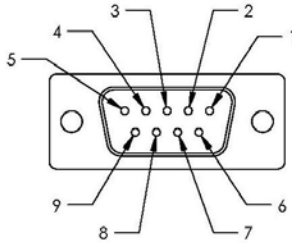

Pin	Signal	Pin	Signal
1	DCD (422TXD-/485DATA-)	2	RXD (422RXD+)
3	TXD (422TXD+/485DATA+)	4	DTR (422RXD-)
5	GND	6	DSR
7	RTS	8	CTS
9	RI	10	N.C.

COM1 RS-232 Serial Port Connector

Pin	Signal	Pin	Signal
1	DCD	2	RXD
3	TXD	4	DTR
5	GND	6	DSR
7	RTS	8	CTS
9	RI	10	N.C.

Chapter

3

**Award BIOS
Setup**

System test and initialization

These routines test and initialize board hardware. If the routines encounter an error during the tests, you will either hear a few short beeps or see an error message on the screen. There are two kinds of errors: fatal and non-fatal. The system can usually continue the boot up sequence with non-fatal errors. Non-fatal error messages usually appear on the screen along with the following instructions:

Press <F1> to RESUME

Press the F1 key to continue the boot up sequence.

System configuration verification

These routines check the current system configuration against the values stored in the boards CMOS memory. If they do not match, the program outputs an error message. You will then need to run the BIOS setup program to set the configuration information in memory.

There are three situations in which you will need to change the CMOS settings:

1. You are starting your system for the first time
2. You have changed the hardware attached to your system
3. The CMOS memory has lost power and the configuration information has been erased.

The AEC-6820 CMOS memory has an integral lithium battery backup. The battery backup should last several years in normal service. However, you will need to replace the battery when it finally runs down.

Award BIOS setup

Awards BIOS ROM has a built-in Setup program that allows users to modify the basic system configuration. This type of information is stored in battery-backed CMOS RAM so that it retains the Setup information when the power is turned off.

Entering setup

Power on the computer and press immediately. This will allow you to enter Setup.



Standard CMOS Features

Use this menu for basic system configuration. (Date, time, IDE, etc.)

Advanced BIOS Features

Use this menu to set the advanced features available on your system.

Integrated Peripherals

Use this menu to specify your settings for integrated peripherals. (Primary slave, secondary slave, keyboard, mouse etc.)

Power Management Setup

Use this menu to specify your settings for power management. (HDD power down, power on by ring, KB wake up, etc.)

PnP/PCI Configurations

This entry appears if your system supports PnP/PCI.

PC Health Status

This menu allows you to monitor temperature, fan speed, and voltage for your system.

Load Fail-Safe Defaults

Use this menu to load the BIOS default values for the minimal/stable performance for your system to operate.

Load Optimized Defaults

Use this menu to load the BIOS default values that are factory settings for optimal performance system operations. While AWARD has designated the custom BIOS to maximize performance, the factory has the right to change these defaults to meet their needs.

Set Supervisor/User Password

Use this menu to set Supervisor/User Passwords.

Save and Exit Setup

Save CMOS value changes to CMOS and exit setup.

Exit Without Saving

Abandon all CMOS value changes and exit setup.

Standard CMOS Features

When you choose the Standard CMOS Features option from the INITIAL SETUP SCREEN menu, the screen shown below is displayed. This standard Setup Menu allows users to configure system components such as date, time, hard disk drive and display. Once a field is highlighted, on-line help information is displayed in the right box of the Menu screen.

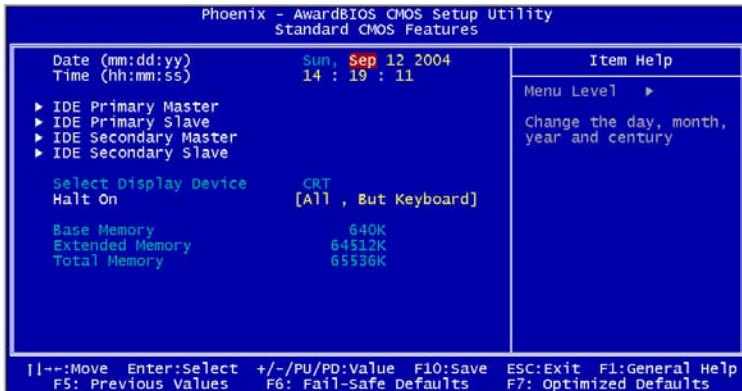

Date and Time Configuration

The BIOS determines the day of the week from the other date information. This field is for information only.

Press the left or right arrow key to move to the desired field (date, month, year). Press the PgUp/- or PgDn/+ key to increment the setting, or type the desired value into the field.

The time format is based on the 24-hour military-time clock. For example, 1 p.m. is 13:00:00 hours. Press the left or right arrow key to move to the desired field. Press the PgUp/- or PgDn/+ key to increment the setting, or type the desired value into the field.

IDE Primary/Secondary Master/Slave

IDE HDD Auto-Detection

The BIOS supports up to two IDE drives. This section does not show information about other IDE devices, such as a CD-ROM drive, or other hard drive types, such as SCSI drives.

NOTE: *We recommend that you select type AUTO for all drives.*

The BIOS can automatically detect the specifications and optimal operating mode of almost all IDE hard drives. When you select AUTO for a hard drive, the BIOS will detect its specifications

IDE Primary Master

If you do not want to select "AUTO", other methods of selecting the drive type are available:

- 1.NONE: No drive type to be selected.
- 2.Manual: This will allow you to manually set the drive type you are using in your system. (See as below)

Access Mode

Auto: The BIOS automatically determines the optimal mode.

CHS: This allows the user to enter their own hardware values.

Large: For drives that do not support LBA and have more than 1024 cylinders.

LBA (Logical Block Addressing): During drive access, the IDE controller transforms the data address described by sector, head, and cylinder number into a physical block address, significantly improving data transfer rates for drives with greater than 1024 cylinders.

Here is a brief explanation of drive specifications:

Capacity: Disk drive capacity (approximate). Note that this size is usually slightly greater than the size of a formatted disk given by a disk-checking program.

Cylinder: Number of cylinders.

Head: Number of heads.

Precomp: Write precompensation cylinder.

Landing Zone: Landing zone.

Sector: Number of sectors.

Select the correct specifications for the diskette drive(s) installed in the computer.

Select Display Device

AEC-6820 can be used with various visual display peripherals. This function allows the end user to select the type of visual display peripheral they are incorporated with the AEC-6820 single board computer.

The choices: CRT

Panel Type

Halt On

During the power-on-self-test (POST), the computer stops if the BIOS detects a hardware error. You can tell BIOS to ignore certain errors during POST and continue the boot-up process.

The choices: All, But Keyboard; All, But Diskette; All, But Disk/Key; All Errors; No Errors.

Memory

You cannot change any values in the Memory fields; they are only for your information. RAM is counted in kilobytes (KB: approximately one thousand bytes) and megabytes (MB: approximately one million bytes).

RAM is the computer's working memory, where the computer stores

programs and data currently being used, so they are accessible to the CPU. Modern personal computers may contain up to 64 MB, 128 MB, or more.

Base Memory

Typically 640 KB. Also called conventional memory. The DOS operating system and conventional applications use this area.

Extended Memory

Above the 1-MB boundary. Early IBM personal computers could not use memory above 1 MB, but current PCs and their software can use extended memory.

Total Memory

The fields show the total installed random access memory (RAM).

Advanced BIOS Features

By choosing the Advanced BIOS Features option from the INITIAL SETUP SCREEN menu, the screen below is displayed. This sample screen contains the manufacturer's default values for the AEC-6820.

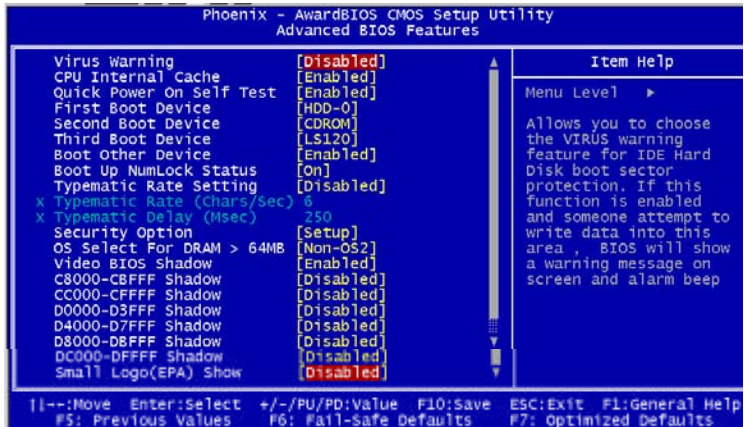

Virus Warning

When enabled, you receive a warning message if a program (specifically, a virus) attempts to write to the boot sector or the partition table of the hard disk drive. You should then run an anti-virus program. Keep in mind that this feature protects only the boot sector, not the entire hard drive.

NOTE: Many disk diagnostic programs that access the boot sector table can trigger the virus-warning message. If you plan to run such a program, we recommend that you first disable the virus warning.

The choices: Enabled, Disabled.

CPU Internal Cache

Enable this function to utilize the CPU Internal Cache memory to enhance computing performance.

The choices: Enabled, Disabled.

Quick Power On Self Test

Select Enabled to reduce the amount of time required to run the power-on-self-test (POST). A quick POST skips certain steps.

The choices: Enabled, Disabled.

First/Second/Third Boot Device

The BIOS attempts to load the operating system from the devices in the sequence selected in these items.

The choices: LS120, HDD-0, HDD-1, HDD-2, CDROM, ZIP100, Disabled.

Boot Other Device

If your boot device is not included in the following choices LS120, HDD0, HDD1, HDD2, SCSI, CDROM, ZIP100, LAN, you may set **First/Second/Third Boot devices to "Disabled"** and **enable the BOOT Other Device function**. The system will automatically boot the other device.

The choices: Enabled, Disabled.

Boot Up NumLock Status

Toggle between On or Off to control the state of the NumLock key when the system boots. When toggled On, the numeric keypad generates numbers instead of controlling cursor operations.

The choices: On, Off.

Typematic Rate Setting

Keystrokes repeat at a rate determined by the keyboard controller. When enabled, the typematic rate and typematic delay can be selected.

The choices: Enabled/Disabled.

Typematic Rate (Chars/Sec)

When the typematic rate setting is enabled, you can select a typematic rate (the rate at which character repeats when you hold down a key) of 6, 8, 10, 12, 15, 20, 24, 30.

Typematic Delay (Msec)

When the typematic rate setting is enabled, you can select a typematic delay (the delay before key strokes begin to repeat) of 250, 500, 750 or 1000 milliseconds.

Security Option

If you have set a password, select whether the password is required every time the System boots, or only when you enter Setup.

The choices: Setup, System.

OS Select For DRAM>64MB

Select the operating system that is running with greater than 64MB or RAM on the system.

The choices: Non-OS2, OS2.

Shadow

Software that resides in a read only memory (ROM) chip on a device is called firmware. The Award BIOS permits shadowing of firmware such as the system BIOS, video BIOS, and similar operating instructions that come with some expansion peripherals such as a

SCSI adaptor.

Shadowing copies firmware from ROM into system RAM, where the CPU can read it through the 16-bit or 32-bit DRAM bus. Firmware not shadowed must be read by the system through the 8-bit X-bus. Shadowing improves the performance of the system BIOS and similar ROM firmware for expansion peripherals. But it also reduces the amount of high memory (640 KB to 1 MB) available for loading device drivers, etc.

Enable shadowing into each section of memory separately. Many system designers hardwire shadowing of the system BIOS and eliminate a System BIOS Shadow option.

Video BIOS shadows into memory are C0000-C7FFF. The remaining areas shown on the BIOS Features Setup screen may be occupied by other expansion card firmware. If an expansion peripheral in your system contains ROM-based firmware, you need to know the address range the ROM occupies to shadow it into the correct area of RAM.

The choices: Enabled, Disabled.

Small Logo (EPA) Show

If you want to show your logo, please enable it.

The choices: Enabled, Disabled

Integrated peripherals

By choosing the Integrated Peripherals from the INITIAL SETUP SCREEN menu, the screen below is displayed. This sample screen contains the manufacturer's default values for the AEC-6820.

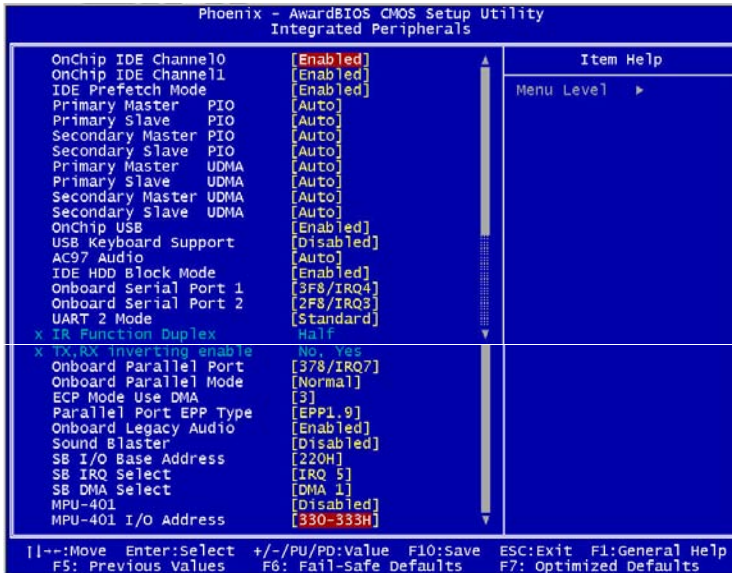

On-chip IDE Channel 0/1

The integrated peripheral controller contains an IDE interface with support for two IDE channels. Please select "Enabled" to activate each channel separately.

The choices: Enabled, Disabled.

IDE Prefetch Mode

The onboard IDE drive interfaces supports IDE prefetching, for faster drive accesses. If you install a primary and/or secondary add-in IDE interface, set this field to Disabled if the interface does not support prefetching.

The choices: Enabled, Disabled.

Primary/Secondary Master/Slave PIO

The four IDE PIO (Programmable Input/Output) fields let you set a PIO mode (0-1) for each of the two IDE devices and the two storage devices that the onboard IDE interface supports. Modes 0 through 4 provide successively increased performance. In Auto mode, the system automatically determines the best mode for each device.

The choices: Auto, Mode 0, Mode 1, Mode 2, Mode 3, Mode 4.

Primary/Secondary Master/Slave UDMA

Ultra DMA33 implementation is possible only if your IDE hard drive supports it and the operating environment includes a DMA driver. If both your hard drive and IDE cable support Ultra DMA 33 select Auto to enable BIOS support.

The choices: Auto, Disable.

On-chip USB

Select Enabled if your system contains a Universal Serial Bus (USB) controller and you have USB peripherals.

The choices: Disabled, Enabled.

USB Keyboard Support

Select Enabled if your system contains a Universal Serial Bus (USB) controller and you have a USB keyboard.

The choices: Disabled, Enabled.

AC97 Audio

Select Enabled to use the audio capabilities of your system.

The choices: Disabled, Enable.

IDE HDD Block Mode

Block mode is also called "block transfer", "multiple commands", or "multiple sector read/write". If your IDE hard drive supports block mode (most new drives do), please select "Enabled" for automatic detection of the optimal number of block read/writes per sector the drive can support.

The choices: Enabled, Disabled.

Onboard Serial Ports 1/2

Normally, the boards' I/O chips will occupy a certain portion of memory space. For each I/O device the computer provides an I/O address. The more devices attached the more address needed to organize the memory storage areas. If all the I/O devices were running through the same address, your devices would come to a near halt. Also the corresponding interrupt needs to be selected.

The choices: Disabled, 3F8/IRQ4, 2F8/IRQ3, 3E8/IRQ4, 2E8/IRQ3.

UART 2 Mode

If you don't disable Onboard Serial Port 2, you will have to select an operating mode for the second serial port:

Standard: RS-232C serial port

HPSIR: IrDA-compliant serial infrared port

ASKIR: Amplitude shift keyed infrared port

If you select HPSIR or ASKIR, you have to set the following two functions.

IR Function Duplex

Select the value required by the IR device connected to the IR port. Full-duplex mode permits simultaneous two-direction transmission. Half-duplex mode permits transmission in one direction only at a time.

The choices: Full, Half.

Tx, Rx inverting enable

Please consult your IR peripheral documentation to select the correct setting of the TxD and RxD signals.

The choices: Yes/No, Yes/Yes, No/No, No/Yes.

Onboard Parallel Port

Select a logical LPT port address and corresponding interrupt for the physical parallel port

The Choice: 3BC/IRQ7, 378/IRQ7, 278/IRQ5, Disabled.

Onboard Parallel Mode

Two bi-directional parallel ports support Normal, ECP, EPP, ECP/EPP.

The choices: Normal, EPP, ECP, ECP/EPP.

ECP Mode Use DMA

Select a DMA channel for the port.

The choices: 1, 3.

Parallel Port EPP Type

You can use this feature to choose which version of EPP to use. For better performance, use EPP 1.9. If you are facing connection issues, try to set it to EPP 1.7.

The choices: EPP1.9, EPP1.7.

Onboard Legacy Audio

Enable to utilize onboard legacy audio function.

The choice: Enabled, Disabled.

Sound Blaster

Enable to utilize Sound Blaster function.

The choice: Enabled, Disabled.

SB I/O Base Address

Select a base I/O address for the Sound Blaster interface.

The choice: 220H, 240H, 260H, 280H

SB IRQ Select

Select Interrupt for the Sound Blaster interface.

The choice: IRQ5, IRQ7, IRQ9, IRQ10

SB DMA Select

Select DMA mode for the Sound Blaster interface.

The choice: DMA0, DMA1, DMA2, DMA3

MPU-401

Select Enabled to configure the MPU-401 interface.

The choice: Enabled, Disabled.

MPU-401 I/O Address

Select a base I/O address for the MPU-401 interface.

The choice: 300-303H, 310-313H, 320-323H, 330-333H.

Power Management Setup

By choosing the Power Management Setup from the INITIAL SETUP SCREEN menu, the screen below is displayed. This sample screen contains the manufacturer's default values for the AEC-6820.

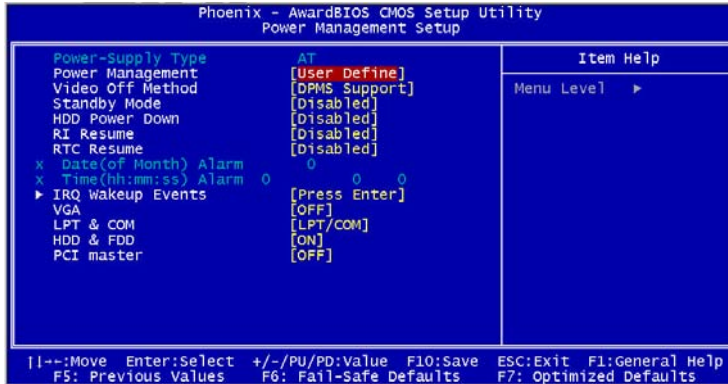

Power Management

Select Max Saving mode or Min Saving mode or define desired Standby Mode and HDD Power Down functions by User Define.

Video Off Method

This determines the manner in which the monitor is blanked.

V/H SYNC + Blank: This selection will cause the system to turn off the vertical and horizontal synchronization ports and write blanks to the video buffer.

DPMS Support: Initial display power management signaling.

Blank Screen: This option only writes blanks to the video buffer.

Suspend Mode

Disable this function or select 30 sec, 1 min, 4 min, 10 min, 20min, 30 min, 1 hour.

HDD Power Down

Disable this function or select from 1 to 15 minutes.

Power Supply Type

AEC-6820 supports two kinds of power supply types: AT or ATX. Please select the corresponding type of your board in this item. If AT type is chosen, this board will not support several power management functions such as "ACPI", "Soft-off by PBTN", "IRQ Wakeup Events"etc.

The choices: AT, ATX.

RTC Resume

When Enabled, you can set the date and time at which the RTC (real-time clock) alarm awakens the system from standby mode.

The choices: Enabled, Disabled

IRQ Wakeup Events (only for ATX type)

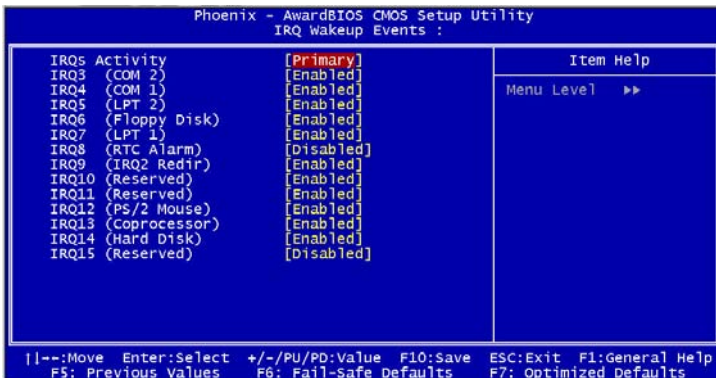

You can turn On or Off monitoring of commonly used interrupt requests so they do not awaken the system from, or reset activity

timers for Doze and Standby modes.

For example, if you have a modem on IRQ3, you can turn on IRQ3 as a wake-up event, so an interrupt from the modem can wake up the system. Or you may wish to turn Off IRQ12 (the PS/2) mouse as a wake-up event, so accidentally brushing the mouse does not awaken the system.

AEC-6820 offers several ways to awaken the system. Define each way as the wake-up interrupts requests or not.

VGA

The choices: ON, OFF

LPT & COM

The choices: LPT, COM, LPT/COM, NONE

HDD

The choices: ON, OFF

PCI Master

The choices: ON, OFF

PnP/PCI configurations

By choosing the PnP/PCI configurations from the Initial Setup Screen menu, the screen below is displayed. This sample screen contains the manufacturer's default values for the AEC-6820.

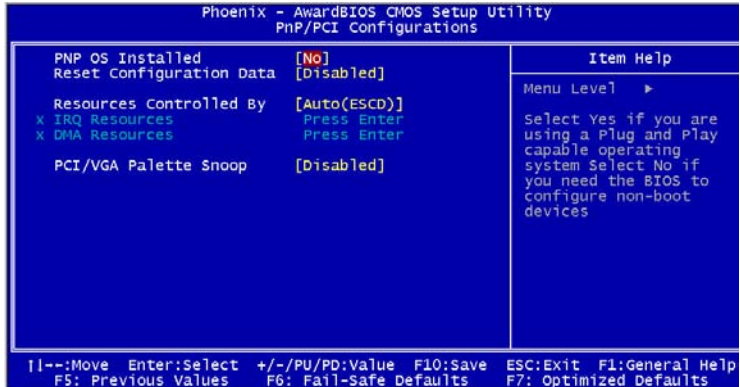

PNP OS Installed

Select “Yes” if the system-operating environment is Plug and Play aware, for example Windows 95.

Select No if you need the BIOS to configure non-boot devices.

The choices: No, Yes.

Reset Configuration Data

Normally, you leave this field disabled. Select enabled to reset Extended System Configuration Data (ESCD) when you exit Setup if you have installed a new add-on and the system reconfiguration has caused such a serious conflict that the operating system cannot boot.

The choices: Enabled, Disabled

Resources Controlled By

The Award Plug and Play BIOS has the capacity to automatically configure all of the boot and Plug and Play compatible devices. However, this capability means absolutely nothing unless you are using a Plug and Play operating system such as Windows 95. If you set this field to Manual, please choose specific resources by going into each of the sub menu that follows this field (a sub menu is preceded by a ">")

The choices: Auto (ESCD), Manual.

IRQ Resources

When resources are controlled manually, assign each system interrupt a type, depending on the type of device using the interrupt. There are two types for choice: **Legacy ISA** and **PCI/ISA PnP**.

Legacy ISA: Devices compliant with the original PC AT bus specification, requiring a specific interrupt (such as IRQ4 for serial port 1)

PCI/ISA PnP: Devices compliant with the Plug and Play standard, whether designed for PCI or ISA bus architecture.

DMA Resources

When resources are controlled manually, assign each DMA channel a type, depending on the type of device using the DMA channel. There are two types for choice: **Legacy ISA** and **PCI/ISA PnP**.

Legacy ISA: Devices compliant with the original PC AT bus specification, requiring a specific DMA channel

PCI/ISA PnP: Devices compliant with the Plug and Play standard, whether designed for PCI or ISA bus architecture.

PCI/VGA Palette Snoop

Leave this field at Disabled.

The choices: Enabled, Disabled

PC Health Status

By choosing the PC Health Status from the Initial Setup Screen menu, the screen below is displayed. This sample screen contains the manufacturer's default values for the AEC-6820.

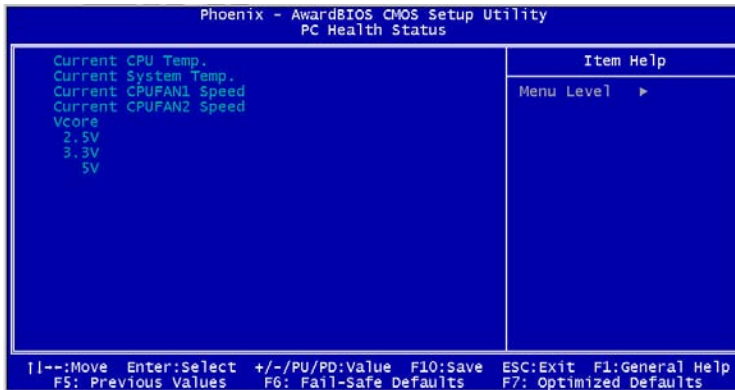

Load Fail-safe Defaults

When you press <Enter> on this item you get a confirmation dialog box with a message similar to:

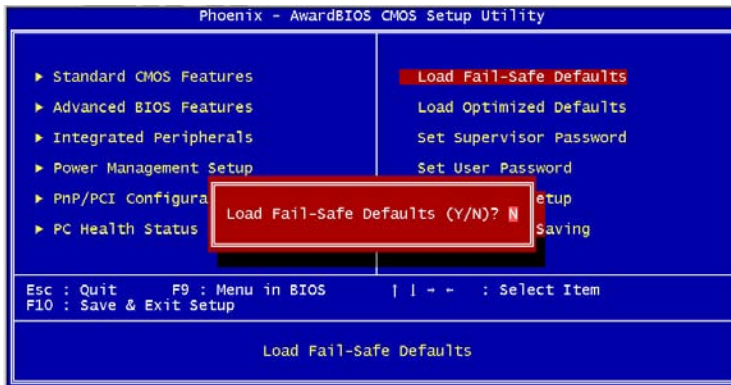

Load Fail-Safe Default (Y/N)?

Pressing "Y" loads the BIOS default values for the most stable, minimal performance system operations.

Load Optimized Defaults

When you press <Enter> on this item you get a confirmation dialog box with a message similar to:

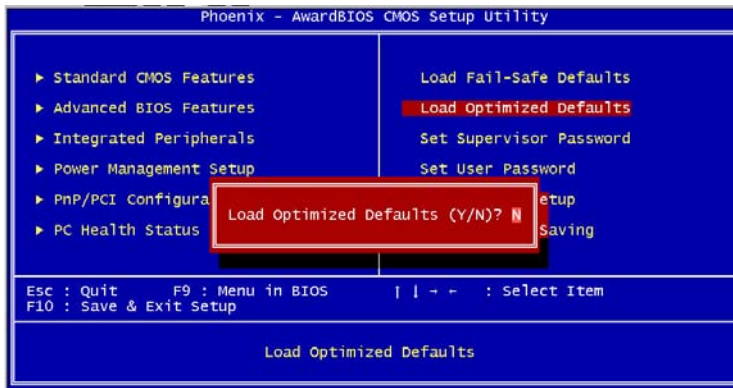

Load Optimized Defaults (Y/N)?

Pressing "Y" loads the default values that are factory settings for optimal performance system operations.

Set Supervisor/User Password

You can set either SUPERVISOR or USER PASSWORD, or both of them. The difference between the two is that the supervisor password allows unrestricted access to enter and change the options of the setup menus, while the user password only allows entry to the program, but not modify options.



To abort the process at any time, press Esc.

In the Security Option item in the BIOS Features Setup screen, select System or Setup:

System Enter a password each time the system boots and whenever you enter Setup.

Setup Enter a password whenever you enter Setup.

NOTE: To clear the password, simply press Enter when asked to enter a password. Then the password function is disabled.

Save & Exit setup

If you select this option and press <Enter>, the values entered in the setup utilities will be recorded in the chipset's CMOS memory. The microprocessor will check this every time you turn your system on and compare this to what it finds as it checks the system. This record is required for the system to operate.

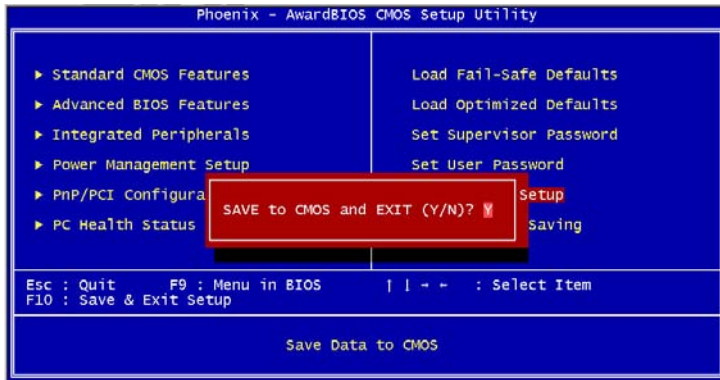

Exit without saving

Selecting this option and pressing <Enter> lets you exit the Setup program without recording any new values or changing old ones.

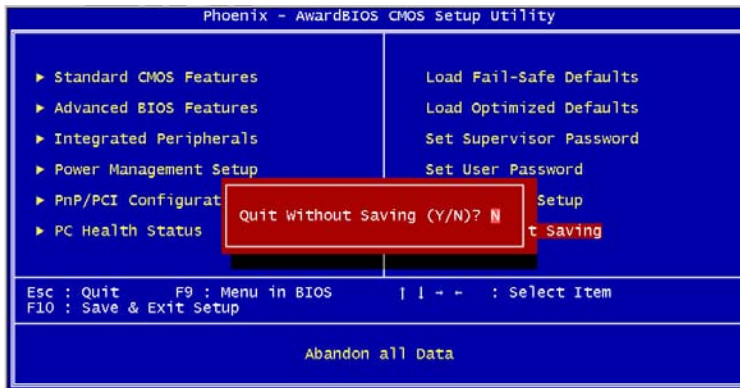

Chapter

4

**Driver
Installation**

AEC-6820 comes with a CD-ROM which contains most of drivers and utilities your will need.

There is several installation ways depends on the driver package under different Operating System application.

We recommend that the system driver installation procedure must be performed first.

If you utilize Windows NT series OS, you are strongly recommended to download the latest version Windows NT Service Pack from Microsoft website and install it before installing any driver.

Limitation:

Due to some bugs of hardware design, AEC-6820 doesn't support 16 bits PCMCIA card in Windows 98/2000 environment.

Installation 1

Applicable for Windows 9x/ME/NT 4.0

1. Insert the AEC-6820 CD-ROM into the CD-ROM Drive.
2. From the CD-ROM, select the desired component Driver folder, select the desired Operation System folder to double click on the Setup.exe icon. A driver installation screen will appear.
(Notice: take VGA driver installation under Windows 98 for example, choose the corresponding folder depending on your OS)
3. A driver installation screen will appear, please follow the onscreen instructions to install the driver in sequence and click on the Next button.
(Notice: In some cases the system will ask you to insert Windows 98 CD Diskette and key in its path. Then click on the OK button to key in path.)
4. Click on the **Finish** button to finish installation process. And allow the system to reboot.

Installation 2

Applicable for Windows 9x/ME

1. Insert the **AEC-6820 CD-ROM** into the CD-ROM Drive.
2. Click on **Start** button, select the **Settings**, and then click on the **Control Panel** icon.
3. Double click on the **Add/Remove Hardware** icon and **Add New Hardware Wizard** will appear. Click on the **Next** button.
4. Select **Search for the best driver for your device (Recommended)** and click on the **Next** button.
5. Select **Specify a location**, click on **Have Disk** button then key in the CD-ROM path and specify component drivers and OS folders. Then click on the **Next** button.
6. The Wizard shows that Windows driver file search for the device: (For example, Ethernet devices, the list appear **Realtek RTL8139/810X Family PCI Fast Ethernet NIC**). Click on the **Next** button.
7. The system will ask you to insert Windows 98 CD Diskette. Click on the **OK** button to insert Diskette and key in path.
8. Click on the **OK** button.
9. Click on the **Finish** button to finish installation process. And allow the system to reboot.

Installation 3

Applicable for Windows NT 4.0

1. Insert the **AEC-6820 CD-ROM** into the CD-ROM Drive.
2. Start system with Windows NT 4.0 installed.
IMPORTANT: When the "Please select the operating system to start..." message is displayed, select "Windows NT Workstation Version 4.00 [VGA mode]".
3. From **Start**, select the **Settings group**, then click on the **Control Panel** icon.
4. In the **Control Panel**, select the desired device and click on the icon.
5. Follow the step-by-step instruction and click on **OK** button.
6. Click on the **Have Disk...** button.
7. Key in CD-ROM path and specify component drivers, then click on the **OK** button.
8. From the list of displayed devices, select your desired device.
9. If a message appears stating the driver is already installed on the system, and asks if you want to use the current or new drivers, be sure to select the **New** button.
10. If prompted for the driver diskette a second time, click on the **Continue** button.
(Notice: In some cases the system will ask you to insert Windows NT CD-ROM. Follow its instructions to complete the setup procedures.)
11. When the message **"The drivers were successfully installed"** is displayed, remove the display driver diskette, then click on the **OK** button.
12. Reboot the system.

Appendix

A

**Programming the
Watchdog Timer**

Programming the Watchdog timer

An on-board watchdog timer reduces the chance of disruptions which CPLD (compact programmable logical device) interference can cause. This is an invaluable protective device for standalone or unmanned applications. When the watchdog timer activates (CPU processing has come to a halt), it can reset the system, or generate an interrupt on IRQ10, IRQ11, IRQ15, and NMI. This can be set via I/O Port 444, the functions as following:

0:	RESET
1:	NMI
2:	IRQ10
3:	IRQ11
4:	IRQ15

If you decide to program the watchdog timer, you must write data to I/O port 443 (hex). The output data is a value timer. You can write from 01 (hex) to FF (hex) for input second data, and the related timer is 1 to 255 seconds.

After data entry, your program must refresh the watchdog timer by rewriting the I/O port 443 (hex) while simultaneously setting it. When you want to disable the watchdog timer, your program should read a Hex value from I/O port 80 (hex).

The following procedure is a sample program for the watchdog timer:

- Type C:\DOS\Debug <Enter>
- To start watchdog timer and set function “Reset” type:

- o 444 0<Enter>; out 444h data 0.
- To input watchdog timers timer-out interval of 5 seconds type:
 - o 443 05<Enter>; out 443h data 05.
- To disable the watchdog timer type:
 - i 80<Enter>

The time interval data of the watchdog timer is shown in binary code (8 bits).

Sample 2: 5 seconds

0	0	0	0	0	1	0	1
---	---	---	---	---	---	---	---