

Skymaster Combo

2-in-1 GPS and GSM Antenna

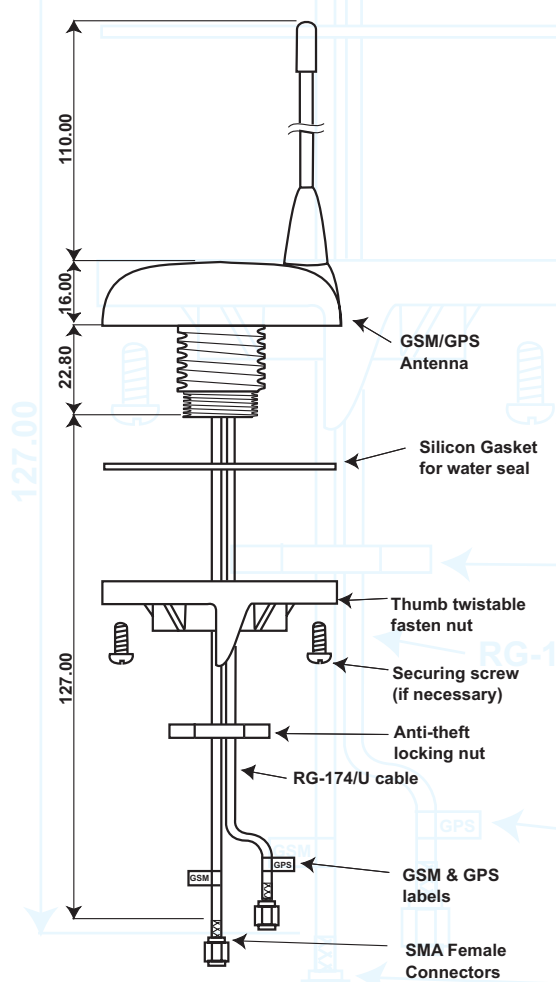

GPS

High performance GPS patch antenna with state-of-the-art low noise amplifier

- Construction: Ø 59.8 x H 438.8mm
- Frequency: 1575.42 ±1.023MHz
- Gain: 27dB typically
- Noise Figure: 1.2 max.
- Attenuation: 20dB min. @ F0 ±50MHz
- Band Width: 10MHz
- VSWR: < 1.5
- Impedance: 50ohm
- Power Consumption: 4.5V to 5.5V DC / 28mA
- Cable: 5m RG-174
- Connector: FME
- Operating Temperature: -35°C to 85°C
- Storage Temperature: -40°C to 90°C

GSM

Multi-band antenna for 900MHz and 1800MHz cellular phone

- Frequency: 870MHz to 960MHz
- Gain: 3dB
- VSWR: < 1.5
- Impedance: 50ohm
- Handling Power: 20W
- Cable: 5m RG-58
- Connector: FME
- Operating Temperature: -35°C to 85°C
- Storage Temperature: -40°C to 90°C

Ordering Information

Part Number
 ■ Skymaster Combo

Description
 ■ 2-in-1 GPS and GSM Antenna



Tri-M Systems and Engineering
 1407 Kebet Way, Unit 100 • Port Coquitlam, BC V3C 6L3 • Canada
 Tel: 604.945.9565 Fax: 604.945.9566 www.Tri-M.com